

FD4T1200C-NR

INDUSTRY
KITCHENS

www.industrykitchens.com.au 1800 611 058

BROMIC[®]
REFRIGERATION

Cake Display 1200mm - 4 Tier

| Food Displays



Cake Display 1200mm - 4 Tier

| Food Displays

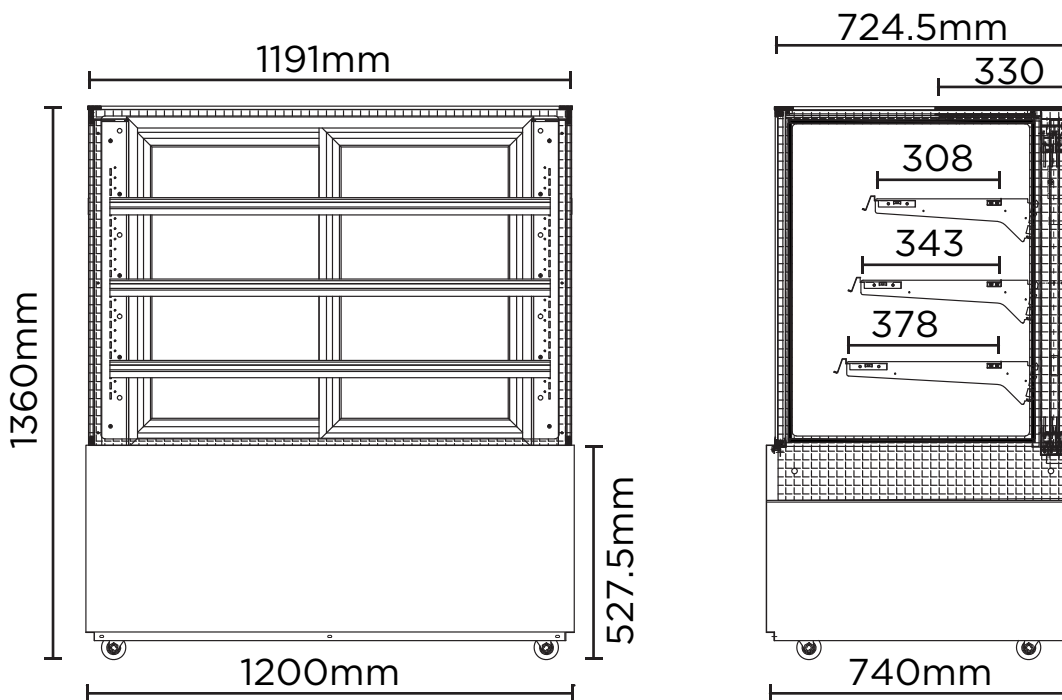

SPECIFICATIONS				DIMENSIONS	
Part Number	3736309-NR	Plug Location	Rear, Bottom Right	External (mm)	
Volume	542L	Internal Light	LED	Width	1200
Unit Weight	282kg	No. of Doors	2	Depth	740
Packaged Weight	292kg	Door Type	Glass	Height	1360
Adjustable Temp. Range	+1°C to +5°C	Door Glass Type	Double Glazed	Internal (mm)	
Max. Ambient Temp. Range	32°C	Door Style	Sliding	Width	1174
Climate Class	3M1	Self-Closing Door	No	Depth	647
Energy Consumption	14.87kWh/24h	No. of Shelves Incl. Base Per Door	4	Height	828
GEMS Star Rating	4 Stars	Shelves Type	Adjustable	Packaged (mm)	
Refrigeration Capacity	1000W	Shelf Dimensions	1117(w) x 307(d), 1117(w) x 342(d), 1117(w) x 377(d) mm	Width	1300
Refrigerant	R290	Temp. Controller	Digital	Depth	850
Rated Current	4.2A	Castors	Yes	Height	1510
Electrical Voltage	220-240V	Warranty	2 Years, Parts & Labour Bromic Extra Care		
Frequency	50Hz				
Power Supply	Single Phase				
Power Plug	1 x 10A				