



772 50HZ SPECIFICATIONS

DIMENSIONS

Countertop unit:

Width: 432 mm (17.0 in.)

Depth: 826 mm (32.5 in.)

Height: 1052 mm (41.4 in.) (with merchandiser door)

CAPACITY (24° C/ 75° F Ambient, FCB Syrup)

Barrel size: 5.2 L (176 oz)

Continuous draw (alternating barrels): 106.5 L/hr (3,600 oz/hr)

Recovery time: 4 minutes

ELECTRICAL REQUIREMENTS

230 VAC single phase, 50 Hz, 3 wire, 20 amp

REFRIGERATION

14,300 BTU/Hr, R-404A

SPACE REQUIREMENTS

Sides or back: 76 mm (3.0 in.) minimum

Top: 914 mm (36.0 in.) minimum

WEIGHT

Operating unit: 145.6 kg (321 lb)

SYRUP CONNECTION

Bag-In-Box (BIB)

MOTORS

Beater: (2) 120 W (1/6 HP)

Fan: 135 W (1/5 HP)

WATER REQUIREMENTS

Fresh water, minimum 9.5 mm (3/8 in.) supply, 207 kPa flowing (30 psi)

OPTIONAL ACCESSORIES

Base cart

Leg kit (set of four)

Painted or stainless steel side panels

Remote condenser (see spec sheet)

Merchandiser options (see spec sheet)

BIB rack

Install kit

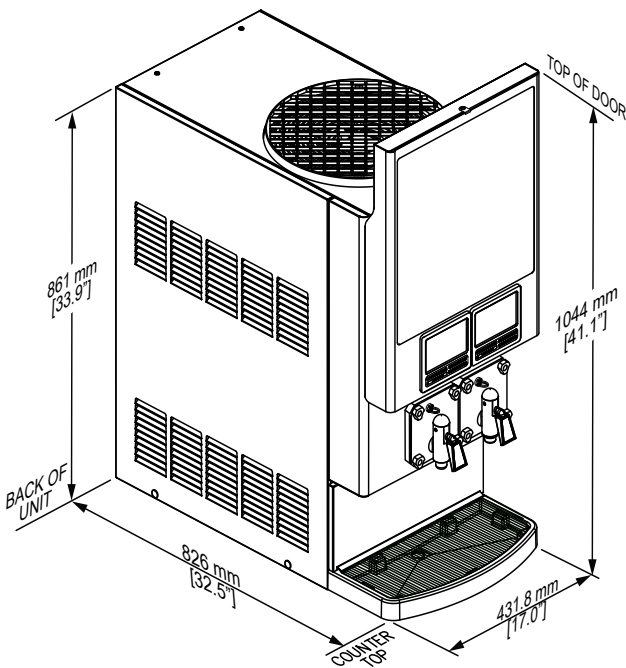

772



Frozen Beverage Dispensers
EVERYONE LOVES FROZEN™
fbdfrozen.com



LANCER

Hoshizaki Lancer
P: +61 8 8268 1388
E: info@lancerbeverage.com
W: www.lancerbeverage.com



Frozen Beverage Dispensers
EVERYONE LOVES FROZEN™

772

ADVANCEMENTS



The 77X series sets a new standard in frozen by combining the superior quality found in all FBD equipment with a range of engineering breakthroughs to create the most innovative frozen beverage dispenser in the world. Featuring an improved capacity and refrigeration system, the 77X is able to dispense more high quality product than ever before while incorporating cost-reducing function such as easier troubleshooting and improved serviceability. The productivity and efficiency of the 77X delivers a powerful message: High profitability. Low Operating Cost.

Everyone Loves Frozen. You'll love frozen more with 77X.

- LED Light Guided Panel—optimized lighting for better, brighter merchandising.
- Simplified User Interface—more intuitive menu interface for an easier, improved user experience.
- Bevtrak Remote Monitoring—remote monitoring with built in diagnostics for faster troubleshooting to minimize machine downtime and lost sales.
- On-screen QR code display for instant access to service information and procedures.
- Integrated Service Platform and removable solution modules for enhanced serviceability.
- Drop-in Control Board—consolidates three board platforms into a single board for easier diagnostic troubleshooting and decreased service related downtime.

PRODUCT FEATURES

- Energy Saving Software utilizes smart compressor cycles and motor management with no effect on drink quality.
- Inline Carbonation™—allows for more consistent expansion, quality and yield.
- AccuFreeze™—maintains product consistency to deliver the most consistent frozen beverage - drink after drink.
- RapidFreeze™—Cold chamber system improves refreeze time while reducing the compressor workload and increasing dispenser durability.
- Scroll™ Compressor—provides more reliable operation and fewer moving parts than reciprocating compressors.
- Customizable individual barrels allow for hundreds of different drink profile combinations which include sugar free options.

772

FBD Partnership, LP | 866.323.2777 | sales@fbdfrozen.com | fbdfrozen.com

change without notice. FBD – Frozen Beverage Dispensers . 8161 Interchange Parkway, Suite 115 • San Antonio, TX 78218 • 210.637.2800 • 1.866.323.2777 • Fax: 210.637.2844 • www.fbdfrozen.com • ©2012 FBD Partnership, LP. FBD®, the FBD logo, and “Everyone Loves Frozen™” are trademarks of FBD Partnership, LP, all rights reserved.