



UC25NDP Undercounter Warewasher



The UC25NDP is a compact undercounter dishwasher featuring automatic operation via a single 'start' button for chosen wash cycles. Equipped with upper and lower wash arms boasting multiple jets, it guarantees thorough wash and rinse coverage. The boost heater, interlocked with machine operation, ensures consistent sanitization. It incorporates new digital displays for easy temperature monitoring. Standard components include a drain pump, detergent pump, and rinse aid injector. Compliant with FSANZ safe food codes, the UC25NDP meets stringent health and sanitary standards with certifications in HACCP and WaterMark.

UC25NDP standard features and benefits

- Up to 500 plates per hour
- Full width tank strainers and dual filtration
- 3 Wash programs to match degree of soil
- Durable stainless-steel body construction and wash arms
- Integrated drain pump as standard
- Detergent pump and rinse aid injector as standard
- Safety cut-off fitted to door
- Easily removable spray arms and filters
- Accurate Digital wash & rinse temperature controllers and displays

Standard accessories

- 1 x plate rack 500 x 500mm
- 1 x cup rack 500 x 500mm
- 1 x cutlery container

Optional accessories part codes

- NK cup rack 500 x 500
- UK plate rack 500 x 500
- CB cutlery container



60 sec



85 sec



115 sec



Please note, due to ongoing product development and improvement, we reserve the right to change product design and specification at any time without notice.



1800 013 123 | +61 2 9604 7333
sales@middleby.com.au
middleby.com.au

VIC - TAS - 47 Stubbs Street, Kensington VIC 3031
QLD - U12, 210 Queensport Rd Nth, Murarrie QLD 4172
WA - U2, 9 Meares Way, Canning Vale WA 6155

HEAD OFFICE
AND MANUFACTURING PLANT
211-217 Woodpark Road, Smithfield NSW 2164

v2_2024



UC25NDP Undercounter Warewasher



- A. Drain ø22mm, 1.8m flexible drain discharge hose
- B. Hot Water Supply 3/4" BSP, 1.5m hose
- C. Power cord, 2m

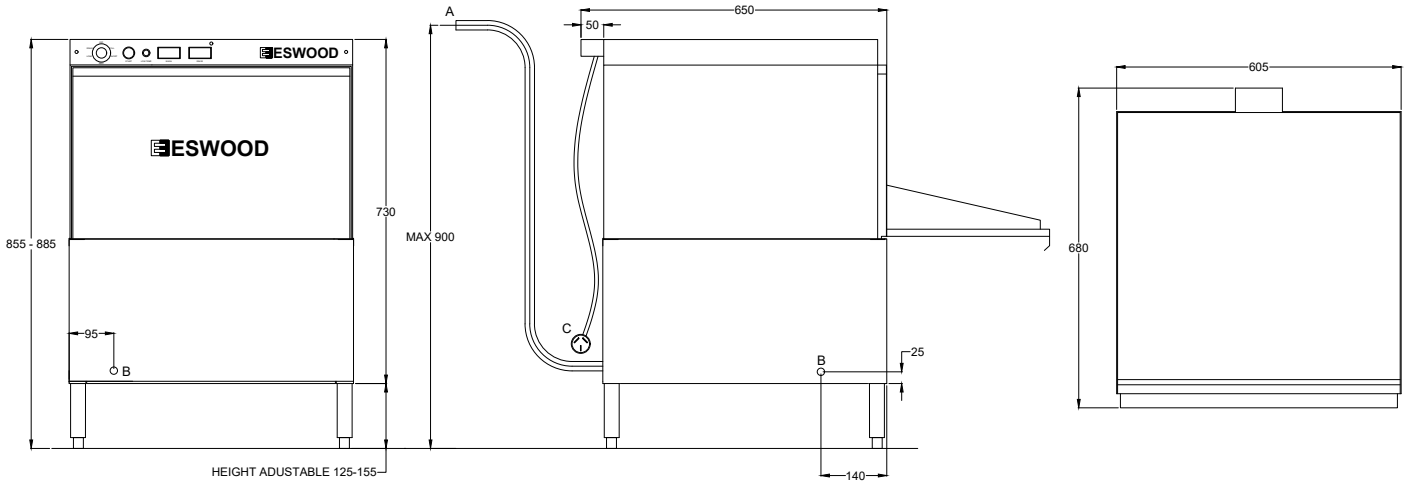

UC25NDP SPECIFICATIONS



PE-388-GE-09

DIMENSIONS (WxDxH)	605 x 670 x 875 mm
DEPTH WITH DOOR OPEN	1000 mm
RACK SIZE, G74N (WxD)	500 x 500 mm
ELECTRICAL CONNECTION	15A Single Phase - 240V
RATING	3.6 kW / 14.9 A
WATER CONNECTION	65°C / 2-4 bar (28-58 psi)
DRAIN CONNECTION	ø22mm
MEAL SERVICE	30 - 60 pax

WASH CYCLE	60, 85 and 115 sec
DETERGENT PUMP	Fitted
RINSE AID INJECTOR	Fitted
DRAIN PUMP	Fitted
WATER CONSUMPTION	3.5L Hot Cycle
TANK CAPACITY	18L
WEIGHT	68 kg
PACKED	0.3m ³

Please note, due to ongoing product development and improvement, we reserve the right to change product design and specification at any time without notice.



1800 013 123 | +61 2 9604 7333
sales@middleby.com.au
middleby.com.au

VIC - TAS - 47 Stubbs Street, Kensington VIC 3031
QLD - U12, 210 Queensport Rd Nth, Murarrie QLD 4172
WA - U2, 9 Meares Way, Canning Vale WA 6155

HEAD OFFICE AND MANUFACTURING PLANT
 211-217 Woodpark Road, Smithfield NSW 2164

v2_2024