



myPRO^{XL} Smart Professional Washer

Built for **smart businesses** needing **extra capacity, longer durability** and **ultra-speed** on a sensible budget

Benefits and features

- ▶ **Top durability with 15.000+ cycle lifetime**
 - Built with commercial components and last nearly six times* longer than domestic washers
 - Top quality SKF bearings in a heavy duty cast iron housing
 - Durable 3 seals with 5 lips protect bearings
 - More durable with 8-point spring suspension and premium steel counterweights
- ▶ **Faster and more efficient washing process**
 - Larger load capacity: 10 kg
 - Default 35 minutes for cold wash program.
 - Save money and energy: the Smart Professional Washer with A+
 - 300 G-force for greatest spin moisture reduction and faster dry time
- ▶ **Increased flexibility and serviceability**
 - Flexible installation thanks to soft mount design and smart drain pump configuration
 - OPL as default, Coin is an optional accessory
 - Optional retrofitable stacking kit for washer+dryer
 - Superb cleanability with 4 field adjustable wash programs
 - Disinfection programs with different temperature and time selection
 - Real-time clock for happy hour, promotional pricing
 - 2 cycle upgrade buttons enhance revenue
 - Front access for easy serviceability

Accessories

- ▶ **Electronic coinmeter for standard alone coin installation**
- ▶ **Mechanical coinmeter for stacked coin installation**
- ▶ **Retrofitable kits for stacked installation both OPL and coin installation**
- ▶ **Liquid detergent supply kit**

* Compared to domestic machines

Main specifications at a glance

Washing capacity, kg	10
Drum volume, l	100
Energy efficiency class	A+
Energy efficiency index, %	>52

Consumption data*

Standard normal 60 °C, full load

Total time, min./cycle	73min
Energy consumption, kWh	1.01
Water consumption (cold+hot), l	87

*Water temperature 15°C cold water and 55°C hot water.

Dimensions

WE1100P

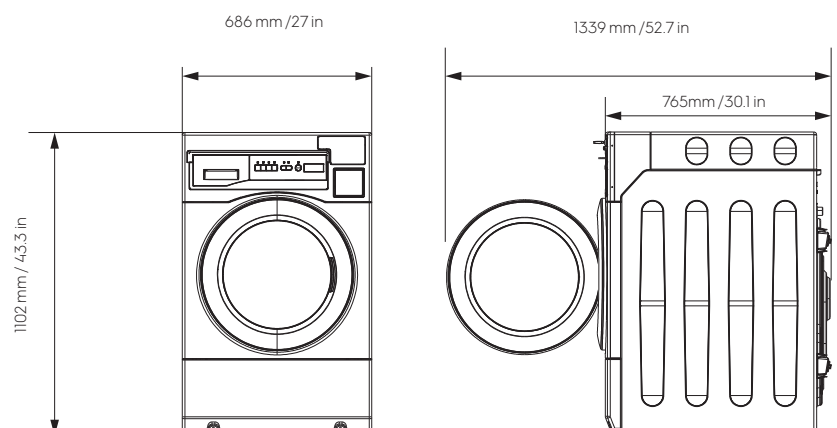

Specifications WE1100P

Wash speed, rpm	45
Spin speed, rpm (G-factor)	1050(300)
Washing noise level, dB(A)	62
Spinning noise level, dB(A)	72
Electrical connection, V/Hz/A	220-240/50Hz/10A
Drive Motor	Inverter
Heating System (kW)	2
Cabinet, top and front	Powder painted
Display	LED
Drum design	Stainless steel
Detergent compartments	3
Water inlet	Cold+Hot
Draining system	Drain pump
Drain hose (mm/in)	25 / 1
Levelling feet	4 adjustable feet

Programs

Number of programs	7
Cold / Warm / Hot / Delicate / Disinfection / Eco40°C / Eco60°C	
Number of additional functions	2
Heavy soild/Extra Rinse	

Dimensions

Product - WxHxD (mm/in)	686 x 1098 x 765 / 27 x 43.2 x 30.1
Width Door Opening (mm/in)	1339/52.7
Carton - WxHxD (mm/in)	776x1174x905/ 30.5x46.5x31.7
Weight - product/carton (kg/lb)	136/146 300/322

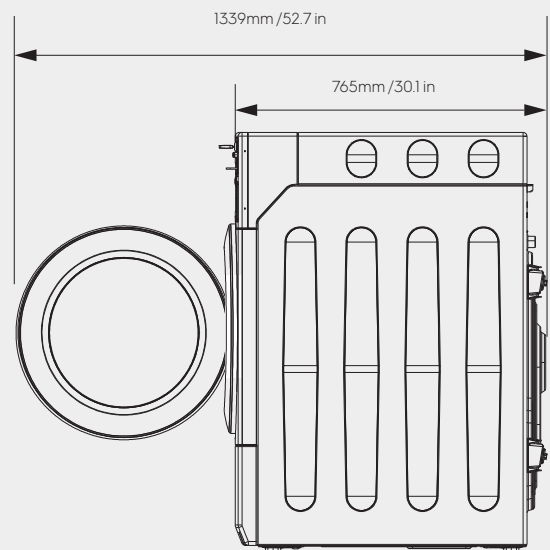
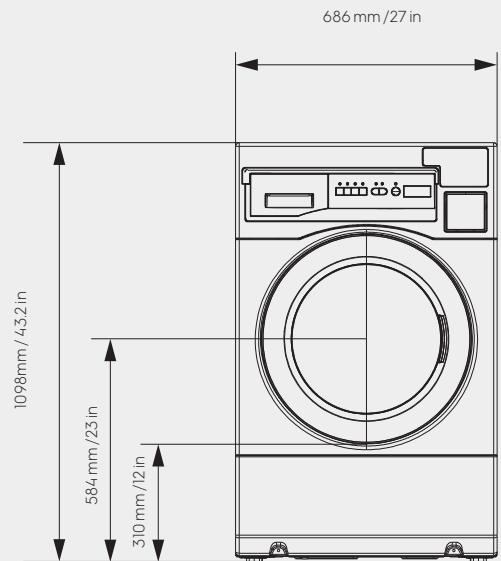

We reserve the right to alter specifications without notice.