



Electrolux
PROFESSIONAL

INDUSTRY
KITCHENS

www.industrykitchens.com.au 1800 611 058

Modular Cooking Range Line 700XP 2 Frontal Hot Plate Electric Induction Cooking Top Range

ITEM # _____

MODEL # _____

NAME # _____

SIS # _____

AIA # _____



371023 (E7INEH2F0P)

Frontal 2-zone (5 kW each)
electric Induction Cooking
Top with rear condiment
holder (6x1/9GN)

Short Form Specification

Item No.

6 mm thick glass ceramic cooking surface with 2 independently controlled 5 kW induction zones. Induction top surface with seamless transition between individual heating zones. Supplied with condiment rail to accept 6x1/9 GN containers. Exterior panels in stainless steel with Scotch Brite finish. One piece pressed work top in 1.5 mm thick stainless steel. Right-angled side edges to allow flush-fitting junction between units.

Main Features

- Almost the entire surface of the ceramic plate can be used without "dead" spots.
- Indicating lamp for each zone located on control console.
- Induction plates endowed with overheating safety device.
- Power to the individual zones can be set with progressive output i.e. fine regulation at the lower and larger progress at the upper levels.
- Low heat dissipation to the kitchen.
- The smooth, glass ceramic plate is not directly heated, so there is no burning on cooking surface.
- The well beneath the container support can be filled with ice to keep condiments cool and incorporates an overflow pipe for drainage.
- IPx4 water protection.
- Glass ceramic cooking surface with 2 independently controlled induction zones with a power of 5 kW per zone.
- Pots diameter to be used : min 12cm, max 28 cm in order to obtain maximum heating efficiency.
- Suitable for countertop installation.

Construction

- All exterior panels in Stainless Steel with Scotch Brite finishing.
- One piece pressed 1.5 mm work top in Stainless steel.
- Model has right-angled side edges to allow flush fitting joints between units, eliminating gaps and possible dirt traps.

Sustainability



- This model is compliant with Swiss Energy Efficiency Ordinance (730.02).

Optional Accessories

- Support for bridge type installation, 800mm PNC 206137
- Support for bridge type installation, 1000mm PNC 206138
- Support for bridge type installation, 1200mm PNC 206139
- Support for bridge type installation, 1400mm PNC 206140
- Support for bridge type installation, 1600mm PNC 206141
- Water column extension for 700 line PNC 206291
- Chimney upstand, 800mm PNC 206304

APPROVAL: _____



Experience the Excellence
www.electroluxprofessional.com

- 2 side covering panels for top appliances PNC 216277
- Stainless steel universal frying pan with stainless steel handle (diam. 200mm) suitable for induction and all other heating sources PNC 653596
- Universal frying pan with stainless steel handle (diam. 240mm) suitable for induction and all other heating sources PNC 653597
- Universal frying pan with stainless steel handle (diam. 280mm) suitable for induction and all other heating sources PNC 653598

Front

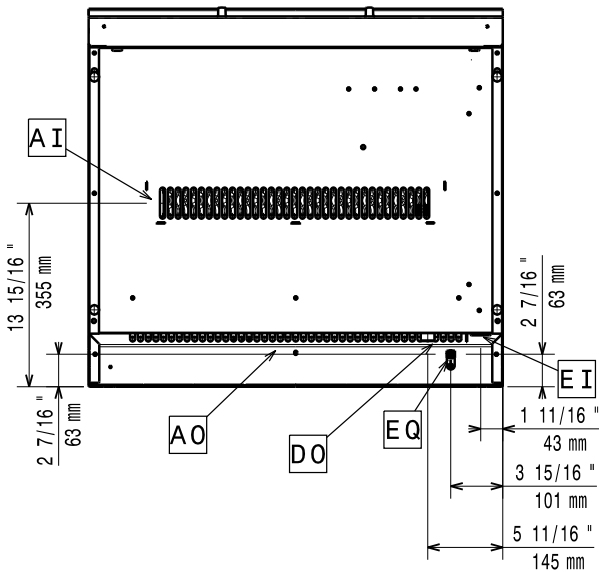

Side

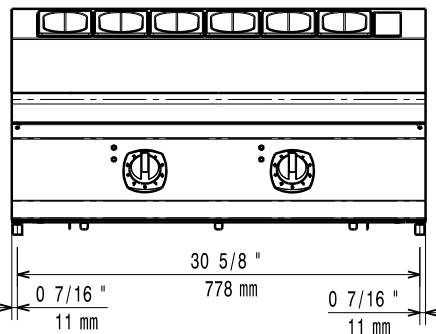

EI = Electrical inlet (power)
EQ = Equipotential screw

Top

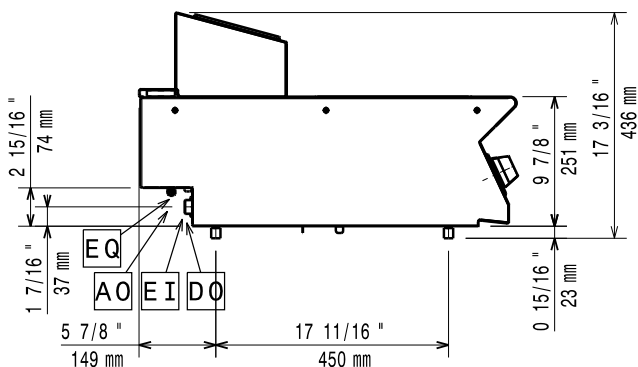

Electric

Supply voltage:	380-415 V/3 ph/50/60 Hz
Predisposed for:	380-415V 3- 50/60Hz
Total Watts:	10 kW

Key Information:

If appliance is set up or next to or against temperature sensitive furniture or similar, a safety gap of approximately 150 mm should be maintained or some form of heat insulation fitted.

Induction compatible pots & pans must be used.

External dimensions, Width:	800 mm
External dimensions, Depth:	730 mm
External dimensions, Height:	250 mm
Net weight:	51 kg
Shipping weight:	60 kg
Shipping height:	690 mm
Shipping width:	820 mm
Shipping depth:	860 mm
Shipping volume:	0.49 m ³
Certification group:	IH72P
Induction Top Dimensions (width):	800 mm
Induction Top Dimensions (depth):	730 mm