



iM 8

Spiral kneading machine for pizza, pastry and bakery



EXTERNAL CONSTRUCTION

- Structure in powder painted stainless steel.
- Spiral, basin, dough-breaker and safety grille in stainless steel.
- Thick frame to avoid vibrations in every working phase.
- Push-button flat panel on the right side.
- Machinery on adjustable feet.

INTERNAL CONSTRUCTION

- Motorization with bath oil motoreducer.
- Chain drive.
- Rotating transmission parts are assembled on self lubricating ball bearings.
- Electrical equipment with low-voltage auxiliary circuit.
- Safety device for grille.
- Monofasic electric motor.

OPERATION

- Dough homogeneity and oxygenation by the combined rotating movement of the utensil and basin.
- The shape of the spiral assures a low and constant temperature of dough during the working.
- Possibility to mix maximum 8 Kg in few minutes.

STANDARD EQUIPMENT

- Spiral
- Basin
- Dough-breaker
- Adjustable feet



MORETTI FORNI S.P.A.

www.morettiforni.com

info@morettiforni.com

Via A.Meucci, 4 - 61037 Mondolfo (PU) ITALIA

Tel. +39.0721.96161 - Fax +39.0721.9616299



IM 8

TOP VIEW

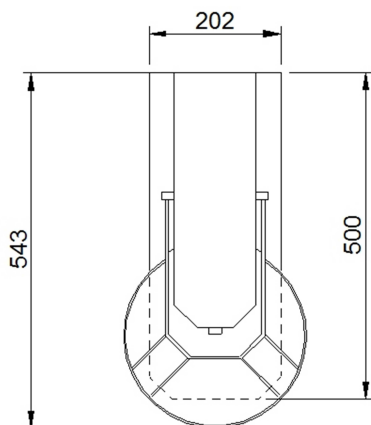

REAR VIEW

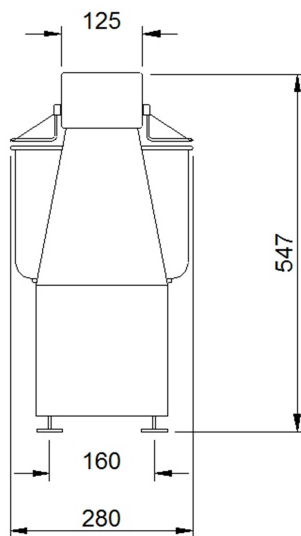

RIGHT SIDE VIEW

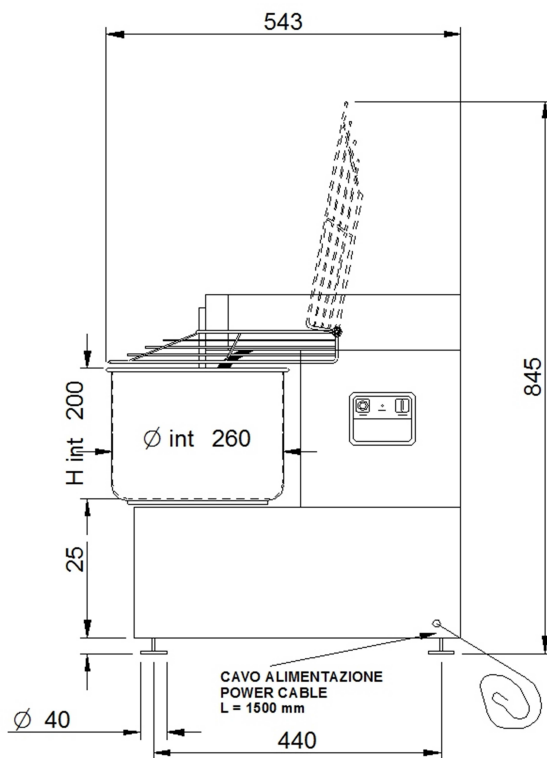

Note: The dimensions indicated in the views are in millimeters

SPECIFICATIONS

Spiral kneading with firm head, ideal for small spaces. To the construction are used high quality and robustness materials. Thanks to the particular shape of spiral and to the rotating movement of the utensil combined with that of the basin, the spiral kneading, gives possibility to mix in few minutes 8 Kg dough, and assures very good homogeneity and oxygenation. The model assures constant temperature of the dough from beginning to end working, so eliminate the danger of incidental overheating. The transmission system is particularly silent because all parts are assembled on water-tight ball bearings with bath oil motor-reducer, free maintenance. The machinery is provided with indispensable safety devices.

TECHNICAL FEATURES

DIMENSIONS

External height	547 mm
External depth	543 mm
External width	280 mm
Weight	42 kg

SHIPMENT INFORMATION

Packed machinery:	
Max height	700 mm
Max depth	610 mm
Max width	340 mm
Weight	(42+5)kg

FEEDING AND POWER

<i>Standard feeding</i>	
A.C. V230 1N Power	0.37 kW
Frequency	50 Hz

BASIN CAPACITY

Capacity (dough)	8 kg
Capacity (volume)	10 lt
Basin internal diameter	260 mm
Basin internal height	200 mm
Spiral diameter	16 mm

<i>Feeding on request</i>	
A.C. V230 1N Power	0.37 kW
Frequency	60 Hz