

## iK 25/2V

Fork kneading machine for pizza, pastry and bakery



### EXTERNAL CONSTRUCTION

- Structure in powder painted stainless steel
- Fork and basin in stainless steel
- Protective transparent cover
- Thick frame to avoid vibrations in every working phase
- Push-button panel on left side
- Machinery on rotating wheels

### INTERNAL CONSTRUCTION

- Motorization with bath oil motoreducer
- Drive belt
- Rotating transmission parts are assembled on self lubricating ball bearings.
- Electrical equipment with low-voltage auxiliary circuits
- Safety device for transparent cover

### OPERATION

- Dough homogeneity and oxygenation by the combined rotating movement of the fork and basin
- The shape of fork assures a low and constant temperature of dough during the working
- Possibility to mix maximum 25 Kg in few minutes and different food products

### STANDARD EQUIPMENT

- Fork
- Basin
- Rotating wheels with brake
- Timer
- 2 speeds

**INDUSTRY**  
**KITCHENS**

[www.industrykitchens.com.au](http://www.industrykitchens.com.au) 1800 611 058



**MORETTI FORNI S.P.A.**

[www.morettiforni.com](http://www.morettiforni.com)

e-mail: [info@morettiforni.com](mailto:info@morettiforni.com)

Via A.Meucci, 4 - 61037 Mondolfo (PU) ITALIA  
Tel. +39.0721.96161 - Fax +39.0721.9616299

## iK 25/2V

TOP VIEW

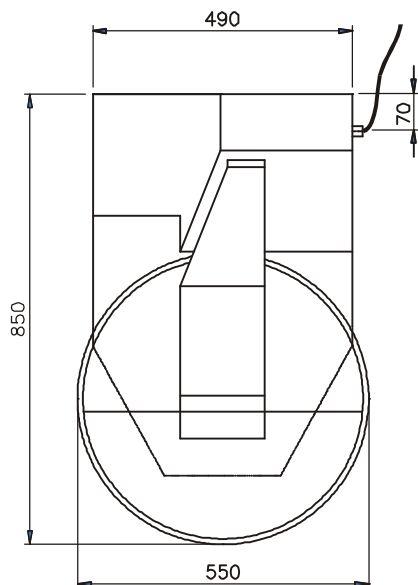

FRONT VIEW

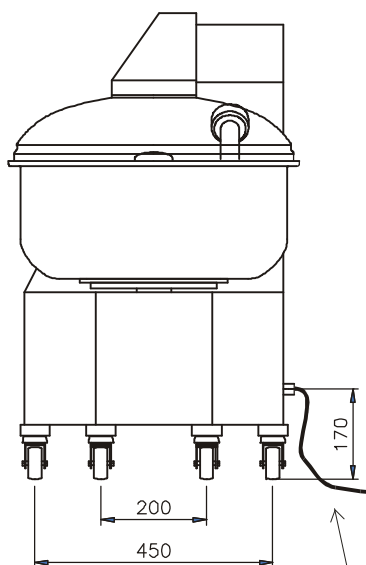

LEFT SIDE VIEW

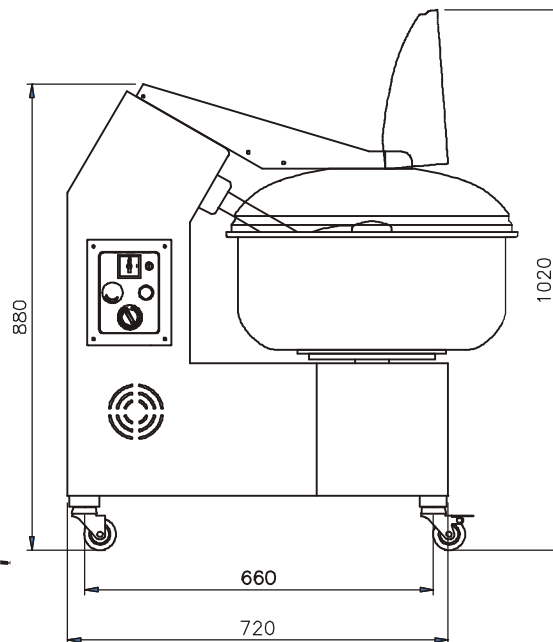

Cavo alimentazione  
L = 1500

**Note:** The dimensions indicated in the views are in millimetres

### SPECIFICATIONS

Fork kneading with wheels ideal for small spaces. To the construction are used height quality and robustness materials. Thanks to the particular shape of fork and to the rotating movement of the utensil combined with that of the basin, the kneading fork, gives possibility to mix in few minutes 25 Kg dough, and assures very good homogeneity and oxygenation. The model assure constant temperature of the dough from beginning to end working, so eliminate the danger of incidental overheating. The transmission system is particularly silent because all parts are assembled on watertight ball bearings with bath oil motoreducer, free maintenance. The machinery is provided of two speeds motor, timer and indispensables safety devices.

### TECHNICAL FEATURES

#### DIMENSIONS

External height	880 mm
External depth	850 mm
External width	550 mm
Weight	141 kg

#### SHIPMENT INFORMATIONS

Packed machinery:	
Max height	985 mm
Max depth	935 mm
Max width	690 mm
Weight	(141+27) kg

#### FEEDING AND POWER

*Standard feeding*  
A.C. V 400 3 50Hz

*Feeding on request*  
A.C. V230 3 50 Hz

Power 0.75/1.1 kW

On request frequency 60 Hz

#### BASIN CAPACITY

Capacity (dough )	25 kg
Capacity (volume)	35 l
Basin internal diameter	500 mm
Basin internal height	200 mm
Fork external diameter	196 mm