

Client _____ Quantity _____
Project _____ Position _____

Master GN counter 2 doors

Model: TP13/1B-710

Cod: T10201000401



Technical data

Top:	With top
Gross capacity:	280 lt
Temperature range:	-15°-22°C
Refrigerant unit:	Plug-In
Energetic class:	D
Energy efficiency index:	61,9
Annual consumption:	2135 kW/h annum
24h consumption:	5,849 kW/h/24h
Climate class:	5
Cooling gas:	R290
Defrost:	Hot gas
Body height:	710 mm
Valve:	Supplied standard with solenoid
Dimensions:	1300×700×850 mm
Packing dimensions:	1395×800×990 mm
Gross weight:	145 Kg
Voltage:	220-240 V - 50 Hz
Total rate:	850 W
Absorbed Current:	3,9 A
Cooling capacity:	569 W*
*:	Evap. -30°C Cond. +55°C

Features

Standard equipment:	2 coppie guida, 2 griglie plastificate GN1/1
Control:	Electronic, display flush with the panel
Doors:	2 doors, self-closing, reversible with 105° stop
Door gasket:	Magnetic, triple chamber and easily replaceable
Insulation:	60 mm thickness - CFC/HCFC free
Exterior/interior finishing:	Exterior interior and back in AISI 304 stainless steel. Base in colaminated steel
Inner corners:	Rounded for easy cleaning and ensuring maximum hygiene
Handle:	Stainless steel AISI 304, 2 mm thick
Racks and slides:	Stainless steel AISI 304
Feets:	Stainless steel AISI 304, adjustable h 100-150 mm
Cosmo:	Ready for connection to Cosmo Hub

Accessories and variants

Drawers 1/2	Service water sink Ø 300 mm
Drawers 1/3	Single lever mixer hole Ø 3/4
Drawers 1/3 + 2/3	Adjustable height of feet: 145/195 mm
Special counter body heights 650 mm	4 Swivel and brake castors h 128 mm
Special counter body heights 700 mm	Brackets for GN pans for drawer
Special counter body heights 750 mm	GN1/2 container + lids kit for drawer, h 150 mm
Technical compartment on the left	GN1/3 container + lids kit for drawer, h 150 mm
Lock with key for drawer 1/2	Bottles shelf, stainless steel coating for shelf 350
Lock with key for drawer 1/3	Stainless steel shelf GN1/1
Lock with key for drawer 1/3 + 2/3	Plastic coated shelf GN1/1
LED lighting	Pair of type C slides 505 mm
RAL customisable colouring	Serial interface, RS485 cable
Plug-in water unit	Cosmo connection kit
Power supply frequency 60Hz	IP44 schuko socket with cover
Other special voltage	Removable plinth GN 2D h 50 mm
Internal hygiene H3	Removable plinth GN 2D h 100 mm
Granite flat worktop	Removable plinth GN 2D h 150 mm
Granite worktop with splashback	

*The installation requires a kit for the replacement of the racks

Technical draw

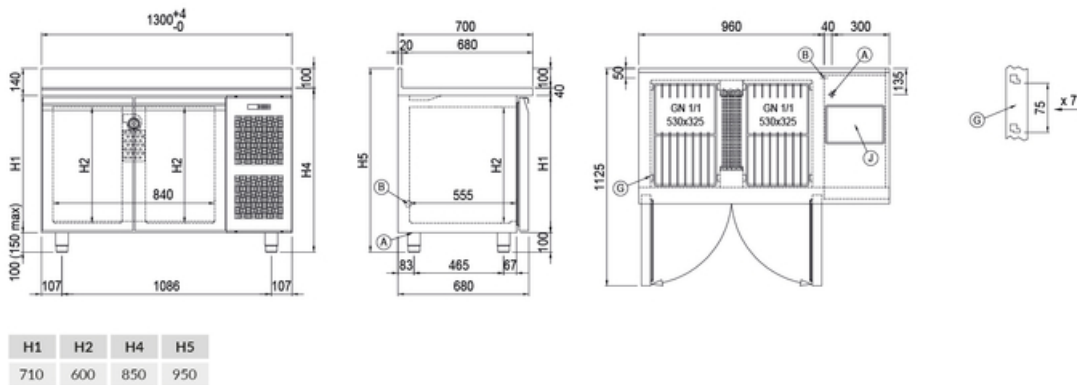

- A:** Power supply cable outlet
B: Condensation water drain
G: Racks pitch
J: Automatic evaporation of condensing water

INDUSTRY KITCHENS

www.industrykitchens.com.au 1800 611 058

In order to constantly offer the best possible products we reserve the right to make changes on technical specifications without incurring any obligation for equipment previously or subsequently sold.