

SF/50 P

Professional Dough Sheeters Machine for Pastry and Bakery



OPTIONS AND ACCESSORIES

(with surcharge)

- Monophasic electric motor 1 speed
- Belt conveyers – measure (500x710)mm

EXTERNAL CONSTRUCTION

- Base structure in painted stainless steel
- Shoulders in aluminium fusion
- Belt conveyer with changeable speed in the two driving directions
- Extractable belt conveyers holder
- Safety devices in stainless steel
- Ergonomic handle to choice dough thickness
- Hand and foot lever to inverse the driving direction
- Sheet of pastry collector in stainless steel
- Machine on wheels

INTERNAL CONSTRUCTION

- Dough rollers diameter 60mm
- Chain drive
- Disassembly scrapers for rolling cylinders
- Electrical system with low-voltage auxiliary circuits
- End run connected to safety devices

FUNCTIONING

- The dough rollers extend any type dough pastry even very thin thickness
- The belt conveyers with changeable speed suitable to avoid wrinkledness
- Raiseble surfaces for overall sizes reducing at rest time

STANDARD EQUIPMENT

- Rolling pins to rolling up the dough after rolling-mill process
- Flour-holder basin

**INDUSTRY
KITCHENS**

www.industrykitchens.com.au 1800 611 058



MORETTI FORNI S.P.A.

www.morettiforni.com

info@morettiforni.com

Via A.Meucci, 4 - 61037 Mondolfo (PU) ITALIA

Tel. +39.0721.96161 - Fax +39.0721.9616299

SF/50 P

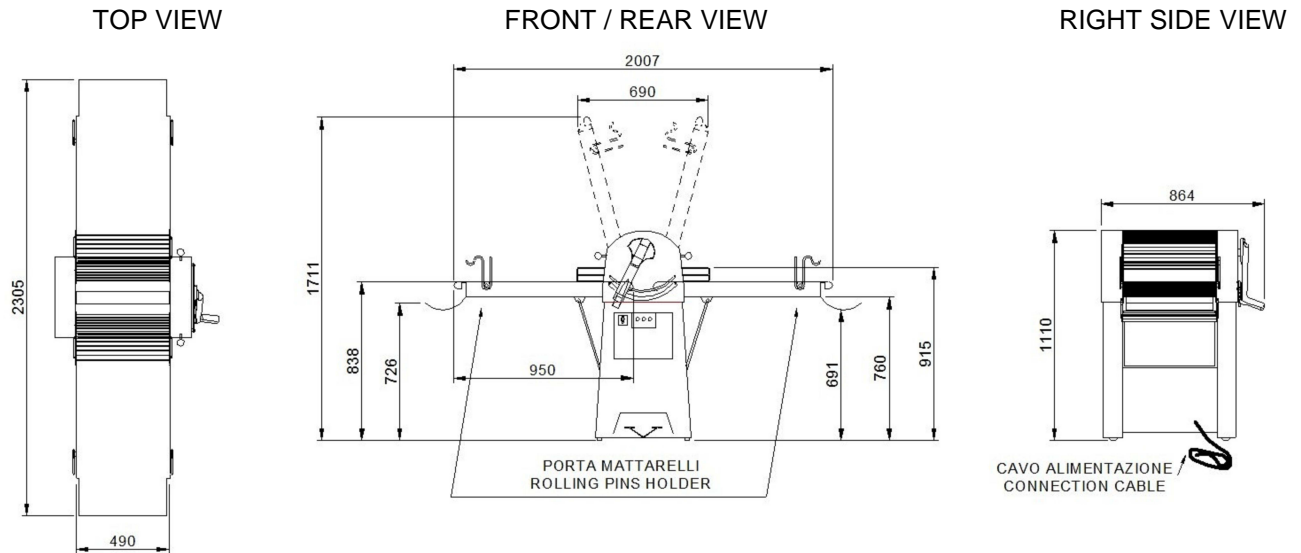

Note: The dimensions indicated in the views are in millimeters

SPECIFICATIONS

Dough sheeters very compact on purpose studied for small spaces. It is equipped of belt conveyers with two speeds in the two driving directions. Easy to use by mean of front control panel. The machine give possibility to obtain different thickness of dough, from 3,5cm to few millimetres, thanks the accurate regulation of the rollers. Raiseble surfaces for overall sizes reducing. The machine is on rotating wheels and has adjustable foots for stability during operation.

The data under indicated are referred to the open machine

DIMENSIONS

Ext height	1110mm
Ext depth	864mm
Ext width	2305mm
Weight	180kg

SHIPMENT INFORMATIONS

Packed machinery:	
Max height	1855mm
Max depth	910mm
Max width	615mm
Weight	(180+10)kg

FEEDING AND POWER

<i>Standard feeding</i>	
A.C. V400 3	
<i>Feeding on request</i>	
A.C. V230 3	
Frequency feeding	50Hz
Frequency on request	60Hz

MACHINE CAPACITY

Belt conveyer	(950x490)mm
Cylinders diameter	60mm
Max cylinder range	35mm

Power	0,75kW
-------	--------

	Cable equipped
Type	4x1,5mm ²
Length	3500mm