

Steel finish



Icon finish

Modular electric deck oven 2 decks composition

serieS is the most advanced and customizable oven in the world, ideal for **perfect baking of pizza, bakery, pastry, and gastronomy.**

Customize serieS choosing dimensions, number, and type of baking chamber, **material** for baking surface (refractory brick, or embossed steel deck, or bakingstone), door opening, Steel or Icon finish, and so much more. serieS meets all production needs thanks to specific and integrable baking chambers: **Multi**bake, **Roman**bake, **Stone**bake, **Pastry**bake e **Steam**bake. Power consumption reduced by 35% and baking speed increased by 20% are the features that make serieS the evolution of baking; the professional oven for those who want to extend their business with a single tool



OPERATION

- Heated by highly performing armoured heating elements
- Temperature management using P.I.D. permit the automatic energy regulation to the quantity of the baked product Adaptive-Power® Technology
- Separated temperature management of ceiling and floor Dual-Temp® Technology
- Separated power management of ceiling and floor Dual-Power® Technology
- Automatic cleaning program for carbonization
- Maximum temperature reached 450°C
- Continuous temperatures monitoring in baking chamber by 2 thermocouples
- Vapour ducting using manual butterfly valve

CONSTRUCTION

- Structure made in folded stainless steel
- Side panels in painted sheet metal
- Channel hood
- Steam duct in stainless steel plate
- Stainless steel door, tempered glass element, door handle in stainless steel
- Aluminated steel top and side structure
- Refractory brick baking surface
- Dual halogen lighting
- Rock wool heat insulation

ACCESSORIES

- Leavening prover on wheels height 600, 800mm
- Stand with wheels height 400, 600, 800, 950, 1050mm
- Leavening with humidifier 250W
- Spacer element height 300mm
- Refractory brick or bakingstone or buckle plate surface
- Additional tray holder guides for compartment and stand
- Motor for hood vapours extraction 500 m3/h
- Max power optimizer (Fource®)
- Reverse door
- Lateral tool-holder for compartment
- Oversized hood, frontless hood H=175 mm
- Remote-Master® Technology for remote management and control

INTERNAL BAKING DIMENSIONS

Internal height	160mm
Internal depth	735mm
Internal width	475mm
Baking surface	0,35m ²

STANDARD EQUIPMENT

- Color multilanguage display TFT 5"
- 100 customized programs with baking steps
- Eco-Standby BY™ Technology for break
- Power-Booster™ Technology for workload peaks
- Half-Load™ Technology for partial load
- Front and rear power balance Delta-Power™ Technology
- Customized Hotkey with recurring control
- Self-diagnosis with error message display
- Independent double baking Timer and Multitimer
- Weekly Timer with the possibility to program two lightings and two power off every day
- Independent security device of maximum temperature
- USB input and wi-fi module for sw update

TOP VIEW

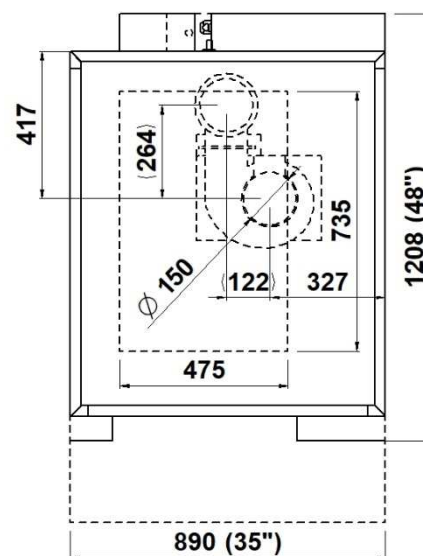

1 baking chamber height 16cm

(assembled with stand height 950mm)

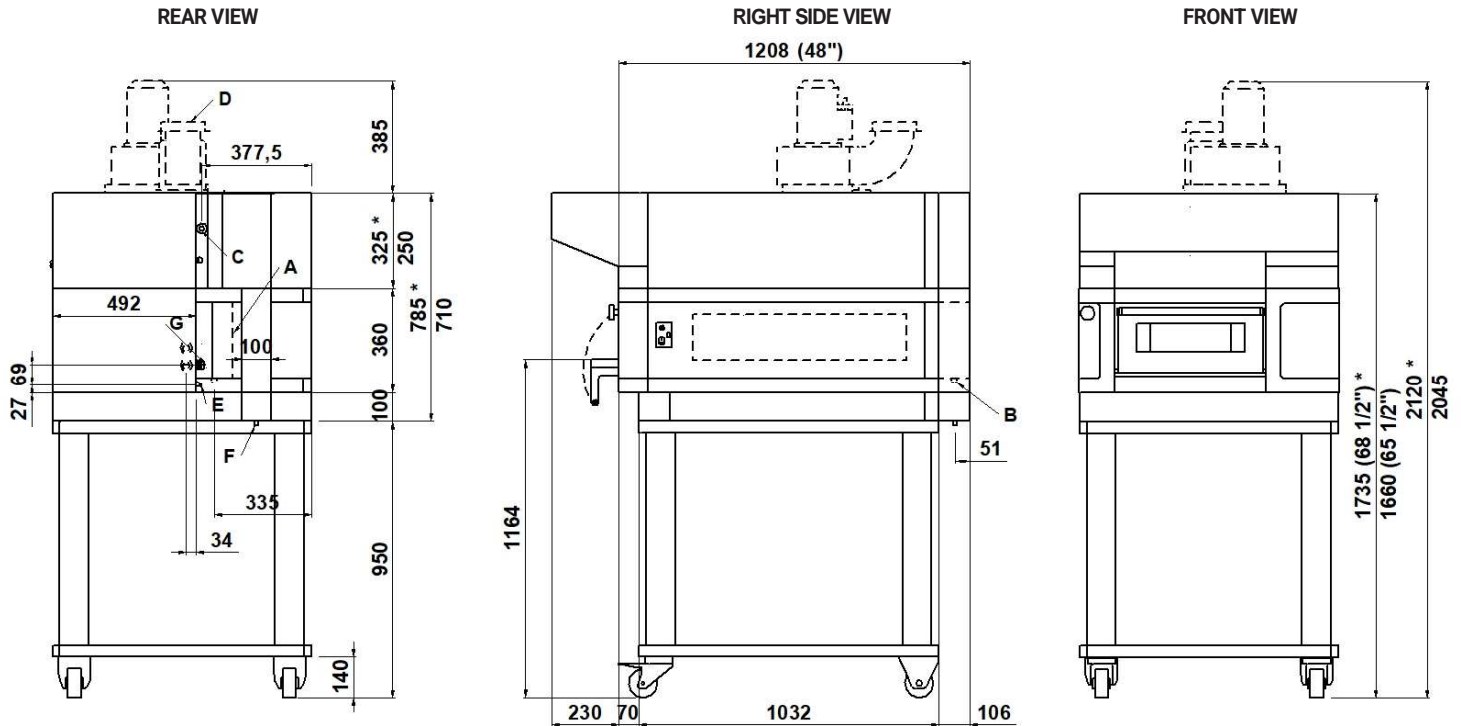

NOTE: The dimensions indicated in the views are in millimeters. *Dimensions refer to the oversized hood.

A steamer 1200W (see data sheet)	B 3/4" male steamer water inlet	C Ø16 Hood condensate exhaust	D Ø150 steam exhaust
E M6 equipotential screws	F Ø12 condensate exhaust	G fairleads	

DIMENSIONS

External height	460mm
External depth	1208mm
External width	890mm
Weight	160kg

SHIPPING INFORMATION

Packed in wooden crate	
Height	860mm
Depth	1643mm
Width	1100mm
Weight	(160+50)kg

FEEDING AND POWER

Standard feeding	
A.C. V400 3N	
Feeding on request	
A.C. V230 3	
Frequency	50/60Hz
Max power	5,1kW
*Average power cons	1,5kWh
Connecting cable for each chamber	
type H07RN-F	
5x2,5mm ² (V400 3N)	
4x4mm ² (V230 3)	
Power supply (optional prover)	
A.C. V230 1N 50/60 Hz	
Max power	1.5kW
*Average power cons	0.8kWh
Conn. Cable type H07RN-F 3x1,5mm ²	

TOTAL BAKING CAPACITY

Tray (600x400)mm	1	When combined with leavening	
Pizza diameter 350mm	2	compartment or stand:	
Pizza diameter 450mm	1	Max height	1810mm
		Max weight	(225+60)kg

* This value is subject to variation according to the way in which the equipment is used

NOTE: MORETTI FORNI S.P.A. reserves the right to modify the characteristics of the products illustrated in this publication without prior notice

2 baking chambers height 16cm
(assembled with prover height 800mm)

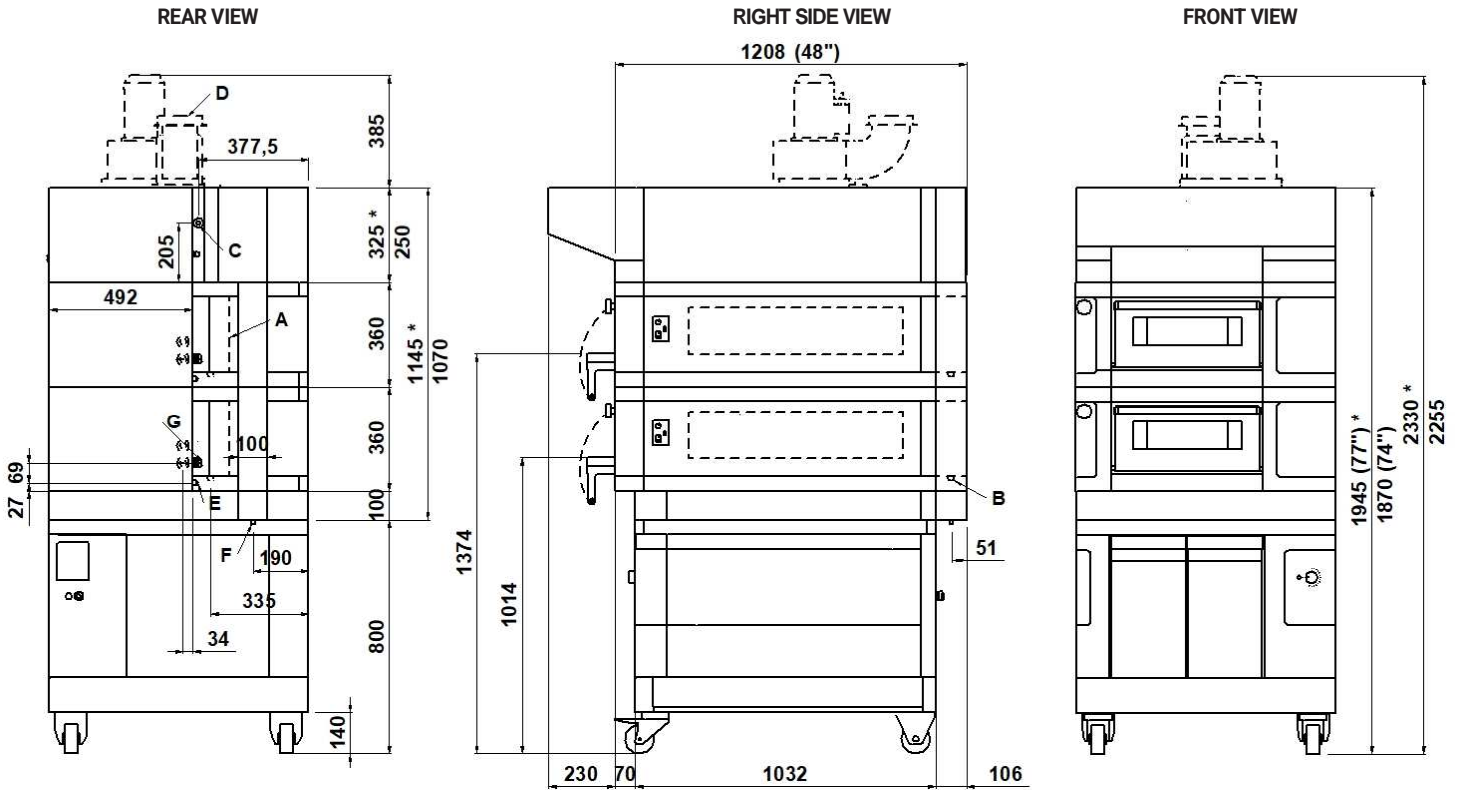

NOTE: The dimensions indicated in the views are in millimeters. *Dimensions refer to the oversized hood.

A steamer 1200W (see data sheet)	B 3/4" male steamer water inlet	C Ø16 Hood condensate exhaust	D Ø150 steam exhaust
E M6 equipotential screws	F Ø12 condensate exhaust	G fairleads	

DIMENSIONS

External height	820mm
External depth	1208mm
External width	890mm
Weight	270kg

TOTAL BAKING CAPACITY

Tray (600x400)mm	2
Pizza diameter 350mm	4
Pizza diameter 450mm	2

SHIPPING INFORMATION

Packed in wooden crate	
Height	1220mm
Depth	1643mm
Width	1100mm
Weight	(270+60)kg
When combined with leavening compartment or stand:	
Max height	2020mm
Max weight	(335+70)kg

FEEDING AND POWER

Standard feeding	
A.C. V400 3N	
Feeding on request	
A.C. V230 3	
Frequency	50/60Hz
Max power	10,2kW
*Average power cons	3,0kWh
Connecting cable for each chamber	
type H07RN-F	
5x2,5mm ² (V400 3N)	
4x4mm ² (V230 3)	
Power supply (optional prover)	
A.C. V230 1N 50/60 Hz	
Max power	1.5kW
*Average power cons	0.8kWh
Conn. Cable type H07RN-F	3x1,5mm ²

* This value is subject to variation according to the way in which the equipment is used

NOTE: MORETTI FORNI S.P.A. reserves the right to modify the characteristics of the products illustrated in this publication without prior notice

3 baking chambers height 16cm
(assembled with prover height 600mm)

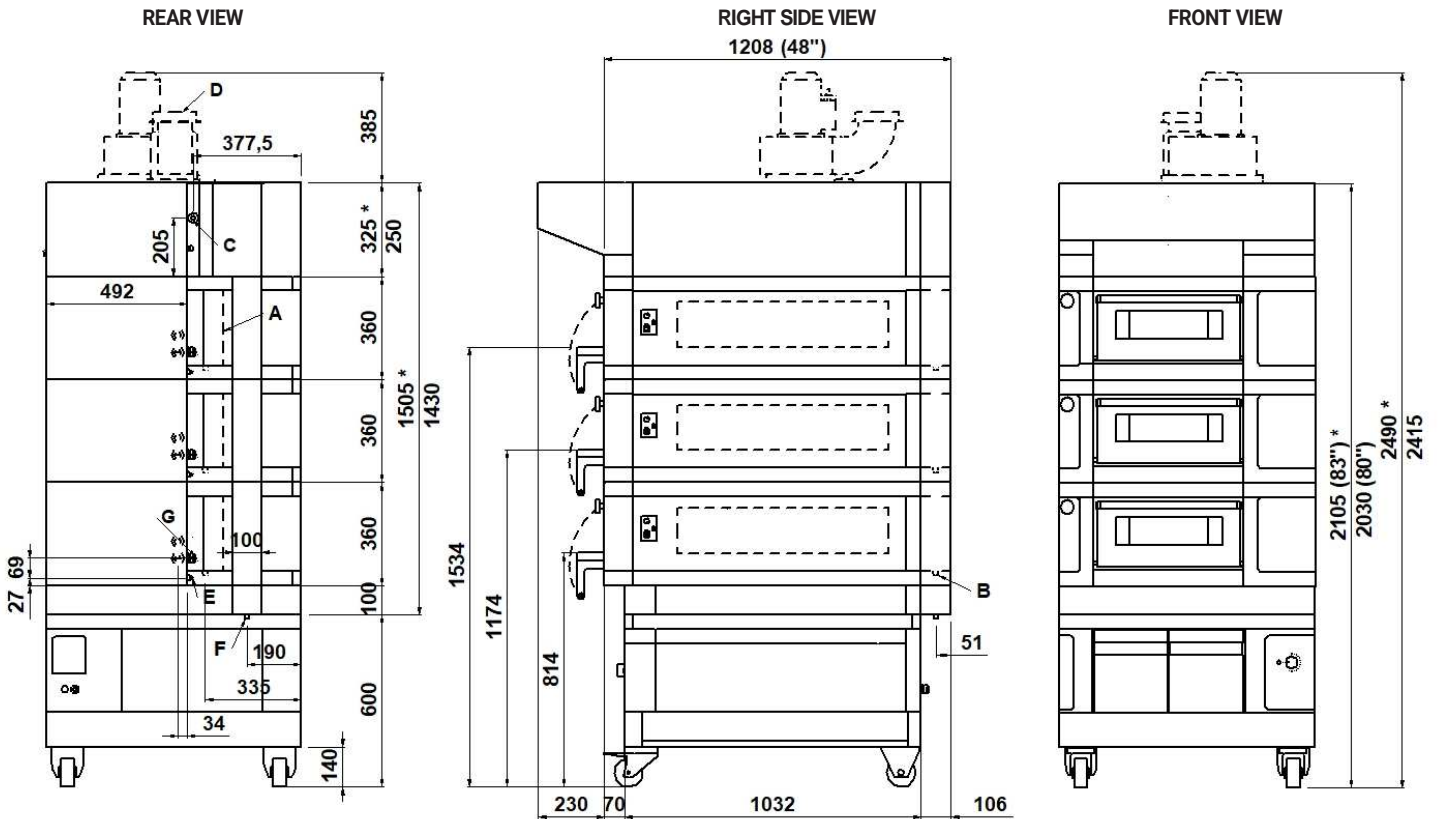

NOTE: The dimensions indicated in the views are in millimeters. *Dimensions refer to the oversized hood.

A steamer 1200W (see data sheet)	B 3/4" male steamer water inlet	C Ø16 Hood condensate exhaust	D Ø150 steam exhaust
E M6 equipotential screws	F Ø12 condensate exhaust	G fairleads	

DIMENSIONS

External height	1180mm
External depth	1208mm
External width	890mm
Weight	380kg

SHIPPING INFORMATION

Packed in wooden crate	
Height	1580mm
Depth	1643mm
Width	1100mm
Weight	(380+70)kg

FEEDING AND POWER

Standard feeding	
A.C. V400 3N	
Feeding on request	
A.C. V230 3	
Frequency	50/60Hz
Max power	15,3kW
*Average power cons	4,5kWh
Connecting cable for each chamber	
type H07RN-F	
5x2,5mm ² (V400 3N)	
4x4mm ² (V230 3)	
Power supply (optional prover)	
A.C. V230 1N 50/60 Hz	
Max power	1.5kW
*Average power cons	0.8kWh
Conn. Cable type H07RN-F 3x1,5mm ²	

TOTAL BAKING CAPACITY

Tray (600x400)mm	3	When combined with leavening	
Pizza diameter 350mm	6	compartment or Stand:	
Pizza diameter 450mm	3	Max height	2180mm
		Max weight	(445+80)kg

* This value is subject to variation according to the way in which the equipment is used

NOTE: MORETTI FORNI S.P.A. reserves the right to modify the characteristics of the products illustrated in this publication without prior notice

2 baking chambers height 16+30 cm
(assembled with prover height 800mm)

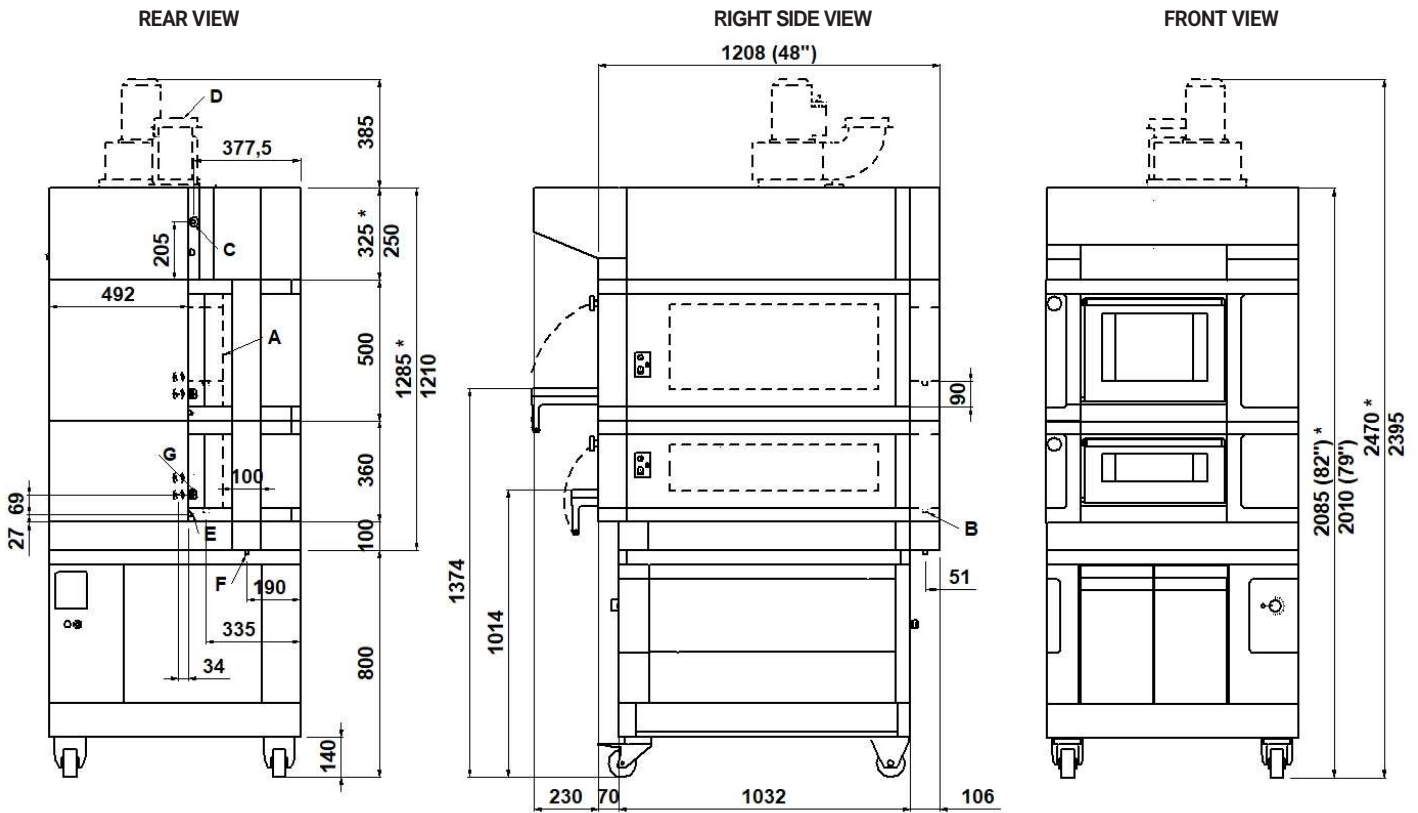

NOTE: The dimensions indicated in the views are in millimeters. *Dimensions refer to the oversized hood.

A steamer 1200W (see data sheet)	B 3/4" male steamer water inlet	C Ø16 Hood condensate exhaust	D Ø150 steam exhaust
E M6 equipotential screws	F Ø12 condensate exhaust	G fairleads	

DIMENSIONS

External height	960mm
External depth	1208mm
External width	890mm
Weight	285kg

TOTAL BAKING CAPACITY

Tray (600x400)mm	2
Pizza diameter 350mm	4
Pizza diameter 450mm	2

SHIPPING INFORMATION

Packed in wooden crate	
Height	1360mm
Depth	1643mm
Width	1100mm
Weight	(285+60)kg

When combined with leavening compartment or stand:	
Max height	2160mm
Max weight	(355+70)kg

FEEDING AND POWER

Standard feeding	
A.C. V400 3N	
Feeding on request	
A.C. V230 3	
Frequency	50/60Hz
Max power	10,2kW
*Average power cons	3,0kWh
Connecting cable for each chamber	
type H07RN-F	
5x2,5mm ² (V400 3N)	
4x4mm ² (V230 3)	
Power supply (optional prover)	
A.C. V230 1N 50/60 Hz	
Max power	1.5kW
*Average power cons	0.8kWh
Conn. Cable type H07RN-F 3x1,5mm ²	

* This value is subject to variation according to the way in which the equipment is used

NOTE: MORETTI FORNI S.P.A. reserves the right to modify the characteristics of the products illustrated in this publication without prior notice

3 baking chambers height 16+16+30 cm
(assembled with prover height 600mm)

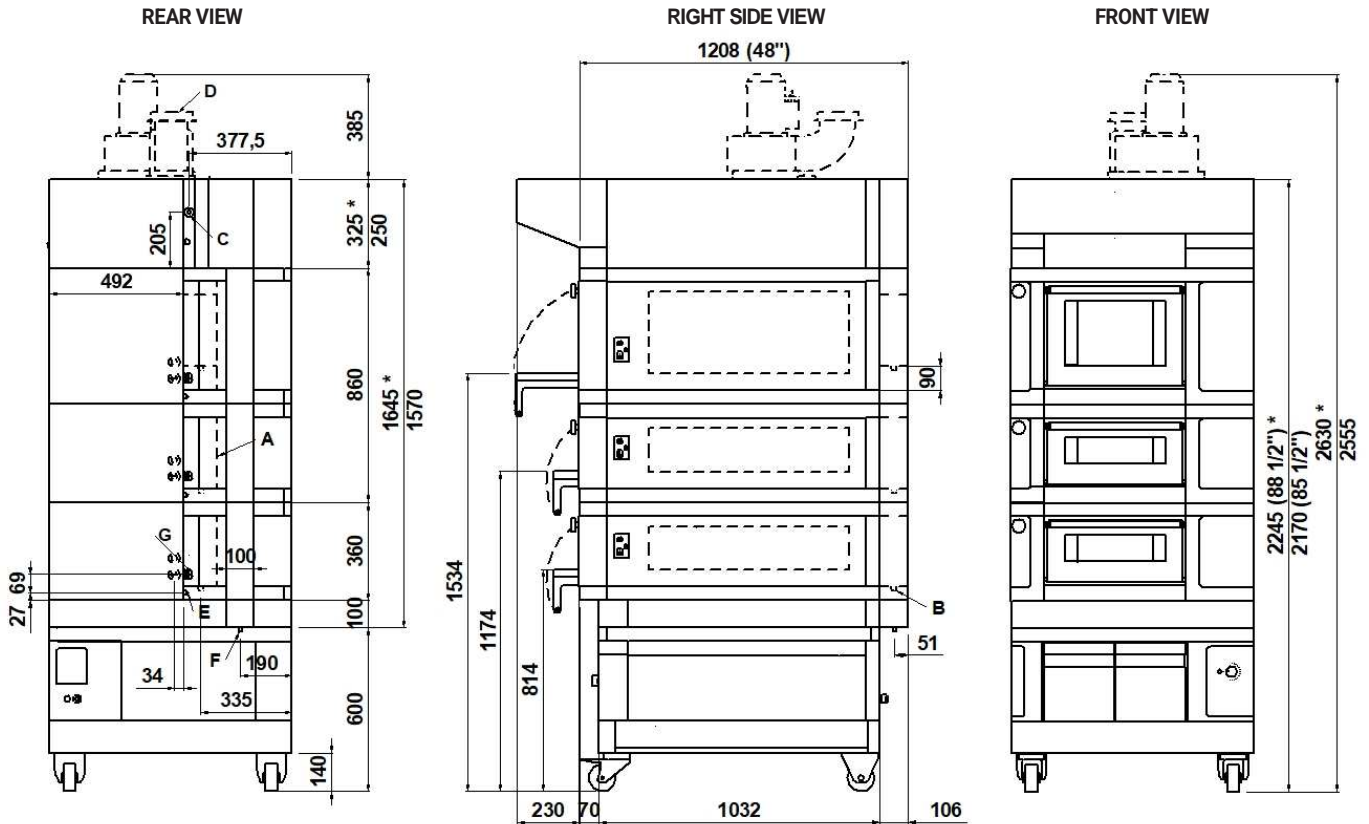

NOTE: The dimensions indicated in the views are in millimeters. *Dimensions refer to the oversized hood.

A steamer 1200W (see data sheet)	B 3/4" male steamer water inlet	C Ø16 Hood condensate exhaust	D Ø150 steam exhaust
E M6 equipotential screws	F Ø12 condensate exhaust	G fairleads	

DIMENSIONS

External height	1320mm
External depth	1208mm
External width	890mm
Weight	395kg

SHIPPING INFORMATION

Packed in wooden crate	
Height	1860mm
Depth	1643mm
Width	1100mm
Weight	(395+70)kg

FEEDING AND POWER

Standard feeding	
A.C. V400 3N	
Feeding on request	
A.C. V230 3	
Frequency	50/60Hz
Max power	15,3kW
*Average power cons	4,5kWh
Connecting cable for each chamber	
type H07RN-F	
5x2,5mm ² (V400 3N)	
4x4mm ² (V230 3)	
Power supply (optional prover)	
A.C. V230 1N 50/60 Hz	
Max power	1.5kW
*Average power cons	0.8kWh
Conn. Cable type H07RN-F 3x1,5mm ²	

TOTAL BAKING CAPACITY

Tray (600x400)mm	3	When combined with leavening	
Pizza diameter 350mm	6	compartment or Stand:	
Pizza diameter 450mm	3	Max height	2180mm
		Max weight	(465+80)kg

* This value is subject to variation according to the way in which the equipment is used

NOTE: MORETTI FORNI S.P.A. reserves the right to modify the characteristics of the products illustrated in this publication without prior notice

S50
TECHNICAL DATA

SHIPPING INFORMATION H16		S50E_1_16	S50E_2_16	S50E_3_16
Packed in wooden crate	Height	860mm	1220mm	1580mm
	Icon height	960mm	1320mm	1680mm
	Weight	(160+50)kg	(270+60)kg	(380+70)kg
When combined with prover or Stand	Max. height	1810mm	2020mm	2180mm
	Max. icon height	1910mm	2120mm	2280mm
	Max. weight	(225+60)kg	(335+70)kg	(445+80)kg
SHIPPING INFORMATION H30		S50E_1_30	S50E_2_30	S50E_3_30
Packed in wooden crate	Height	1000mm	1500mm	2000mm
	Icon height	1100mm	1600mm	2100mm
	Weight	(175+50)kg	(285+60)kg	(395+70)kg
When combined with prover or Stand	Max. height	1950mm	2400mm	2600mm
	Max. icon height	2050mm	2500mm	2700mm
	Max. weight	(245+60)kg	(355+70)kg	(465+80)kg
SHIPPING INFORMATION STONEBAKE		S50R_1_16	S50R_2_16	S50R_3_16
Packed in wooden crate	Height	860mm	1220mm	1580mm
	Icon height	960mm	1320mm	1680mm
	Weight	(180+50)kg	(310+60)kg	(440+70)kg
When combined with prover or Stand	Max. height	1810mm	2020mm	2180mm
	Max. icon height	1910mm	2120mm	2280mm
	Max. weight	(245+60)kg	(375+70)kg	(495+80)kg

FEEDING AND POWER (REFERRED TO 1 BAKING CHAMBER)	Max power	Multibake	kW	5,1
	*Average power consumption		kWh	1,5
	Max power	Stonebake	kW	5,1
	*Average power consumption		kWh	1,5
	Max power	Romanbake	kW	6
	*Average power consumption		kWh	1,8
	Max power	Steambake	kW	6,3
	*Average power consumption		kWh	1,9
	Max power	Pastrybake	kW	3,8
	*Average power consumption		kWh	1,1

MAX TEMPERATURE	Multibake/Stonebake/Romanbake	°C/°F	450°C	842°F
	Steambake		350°C	662°F
	Pastrybake		270°C	518°F

* This value is subject to variation according to the way in which the equipment is used
NOTE: MORETTI FORNI S.P.A. reserves the right to modify the characteristics of the products illustrated in this publication without prior notice