



## Electric deck oven for pizza 2 decks composition

iDeck consists of one or two baking chambers and an optional proofer or stand. The oven's baking surface is made of refractory material, providing the perfect heat distribution over the whole surface. This oven is particularly suitable for direct or indirect pizza baking. Temperature adjustment is electro-mechanical, with independent control of the ceiling and floor heating elements. The oven door is hinged at the bottom, with a tempered glass window to check the product during baking. The stand consists of a painted metal structure, while the proofer is a stainless steel cabinet equipped with a heating thermostat. The proofer can reach the maximum temperature of 65°C(149°F), whereas the maximum temperature of the baking chamber is 450°C (842°F).



### FUNCTIONING

- Heating by armoured heating elements
- Separate heating element control by mean contactors that are controlled by thermostats
- Maximum temperature reached 450°C
- Continuous measurement of temperature by probe indicator

### CONSTRUCTION

- Front structure made in folded stainless steel
- Oven panels made pre-painted metal sheets
- Door in stainless steel with shutter with hinge at bottom with balancing spring
- Door handle in stainless steel
- Tempered crystal glass
- Control panel on the right front side
- Baking surface in refractory brick
- Upper and lateral structure in aluminized sheet
- Thermal insulation in mineral wool

### BAKING ELEMENT INTERNAL DIMENSIONS

|                 |                    |
|-----------------|--------------------|
| Internal height | 140 mm             |
| Internal depth  | 660 mm             |
| Internal width  | 614 mm             |
| Baking surface  | 0,4 m <sup>2</sup> |

### STANDARD EQUIPMENT

- Illumination by halogen lamp
- Independent maximum temperature safety device (only electronic version)

### ACCESSORIES

- Prover on wheels height 700, 1000 mm
- Stand height 600, 900 mm
- 4 wheels kit
- Additional trayholder slides
- Stacking kit
- Hood

### TOP VIEW

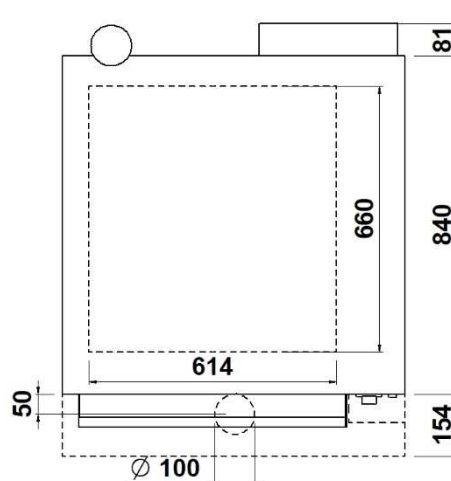

**PM 60.60**

(assembled with stand height 950mm)

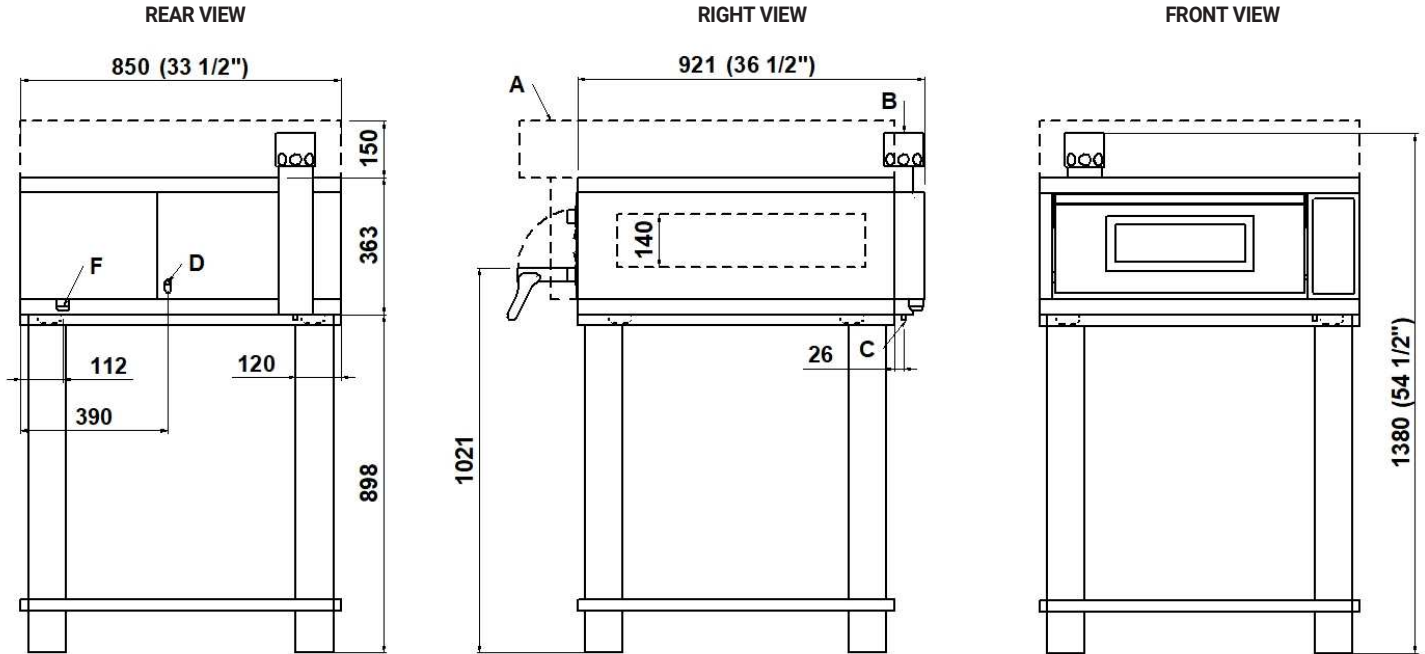

NOTE: The dimensions indicated in the views are in millimeters.

|  |   |                                       |                                       |
|--|---|---------------------------------------|---------------------------------------|
| <b>A</b><br>Ø100<br>hood steam collector | <b>B</b><br>Ø INT. 102<br>steam exhaust | <b>C</b><br>Ø12<br>condensate exhaust | <b>D</b><br>M6<br>equipotential screw |
| <b>F</b><br>fairleads                    |   |                                       |                                       |

**EXTERNAL DIMENSIONS**

|                 |        |
|-----------------|--------|
| External height | 481 mm |
| External depth  | 921 mm |
| External width  | 850 mm |
| Weight          | 80 kg  |

**SHIPPING INFORMATION**

Packed oven sizes:

|        |            |
|--------|------------|
| Height | 560 mm     |
| Depth  | 1060 mm    |
| Width  | 920 mm     |
| Weight | (80+13) kg |

**FEEDING AND POWER**

|                                |                                |
|--------------------------------|--------------------------------|
| Standard feeding               | A.C. V400 3N                   |
| Feeding on request             | A.C. V230 3, A.C. V230 1N      |
| Frequency                      | 50/60 Hz                       |
| Max power                      | 4,2 kW                         |
| *Average power cons            | 2,1 kWh                        |
| Connecting cable               | type H07RN-F                   |
|                                | 5x2,5mm <sup>2</sup> (V400 3N) |
|                                | 4x4mm <sup>2</sup> (V230 3)    |
|                                | 3x4mm <sup>2</sup> (V230 1N)   |
| Prover power supply (optional) | A.C. V230 1N 50/60 Hz          |
| Max power                      | 1 kW                           |
| *Average power cons            | 0,5 kWh                        |
| Conn. cable type               | H07RN-F 3x1,5mm <sup>2</sup>   |

**TOTAL BAKING CAPACITY**

|                      |   |
|----------------------|---|
| Tray (600x400)mm     | 1 |
| Pizza diameter 300mm | 4 |
| Pizza diameter 450mm | 1 |

\* This value is subject to variation according to the way in which the equipment is used  
NOTE: MORETTI FORNI S.P.A. reserves the right to modify the characteristics of the products illustrated in this publication without prior notice

**PD 60.60**

(assembled with stand height 900mm)

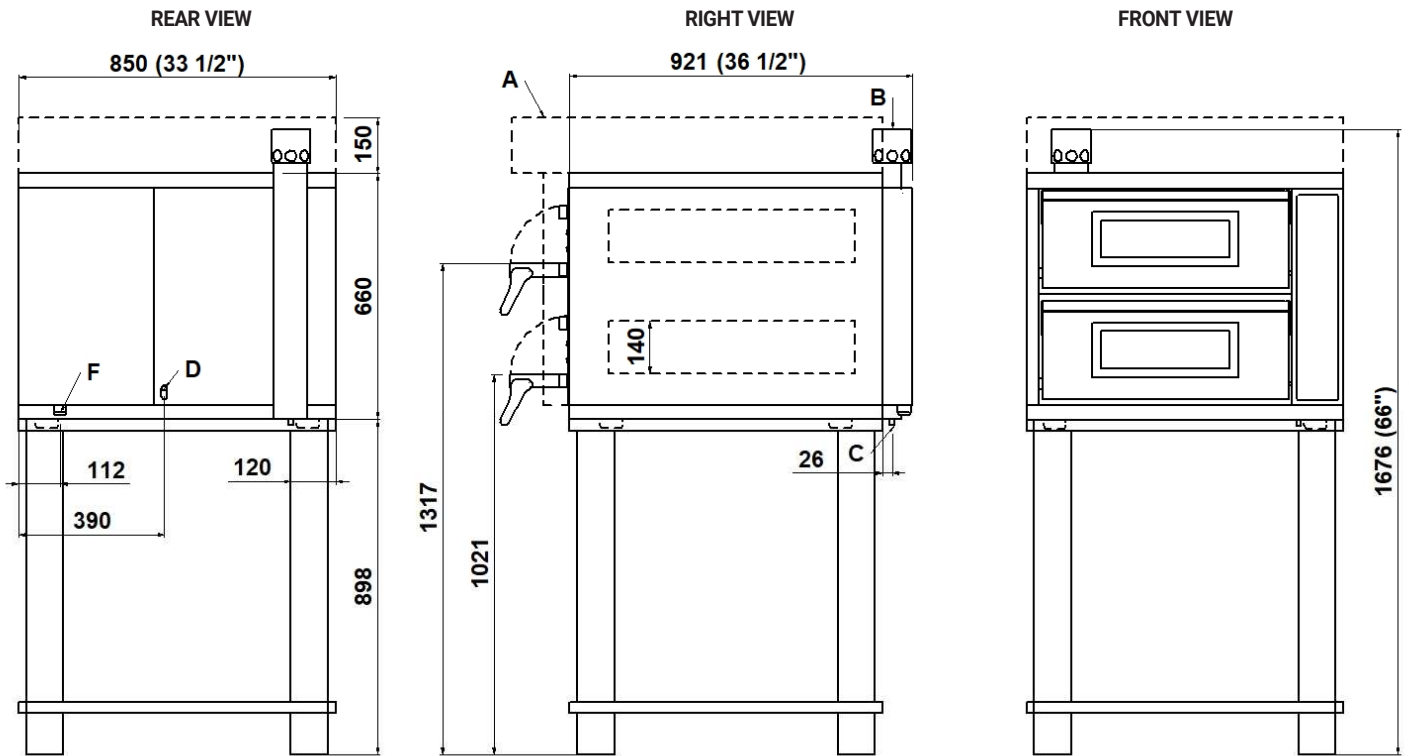

NOTE: The dimensions indicated in the views are in millimeters.

|  |   |                                       |                                       |
|--|---|---------------------------------------|---------------------------------------|
| <b>A</b><br>Ø100<br>hood steam collector | <b>B</b><br>Ø INT. 102<br>steam exhaust | <b>C</b><br>Ø12<br>condensate exhaust | <b>D</b><br>M6<br>equipotential screw |
| <b>F</b><br>fairleads                    |   |                                       |                                       |

**EXTERNAL DIMENSIONS**

|                 |        |
|-----------------|--------|
| External height | 778 mm |
| External depth  | 921 mm |
| External width  | 850 mm |
| Weight          | 133 kg |

**SHIPPING INFORMATION**

|                    |             |
|--------------------|-------------|
| Packed oven sizes: |             |
| Max height         | 840 mm      |
| Max depth          | 1060 mm     |
| Max width          | 920 mm      |
| Weight             | (133+14) kg |

**FEEDING AND POWER**

|   |          |
|---|----------|
| Standard power supply                         |          |
| A.C. V400 3N                                  |          |
| Optional power supply                         |          |
| A.C. V230 3, A.C. V230 1N                     |          |
| Frequency                                     | 50/60 Hz |
| Max power                                     | 8,4 kW   |
| *Average power cons                           | 4,2 kWh  |
| Connecting cable                              |          |
| type H07RN-F                                  |          |
| 5x4mm <sup>2</sup> (V400 3N)                  |          |
| 4x6mm <sup>2</sup> (V230 3)                   |          |
| 3x10mm <sup>2</sup> (V230 1N)                 |          |
| Prover power supply (optional)                |          |
| A.C. V230 1N 50/60 Hz                         |          |
| Max power                                     | 1 kW     |
| *Average power cons                           | 0,5 kWh  |
| Conn. cable type H07RN-F 3x1,5mm <sup>2</sup> |          |

**TOTAL BAKING CAPACITY**

|                      |   |
|----------------------|---|
| Tray (600x400)mm     | 2 |
| Pizza diameter 300mm | 8 |
| Pizza diameter 450mm | 2 |

\* This value is subject to variation according to the way in which the equipment is used

NOTE: MORETTI FORNI S.P.A. reserves the right to modify the characteristics of the products illustrated in this publication without prior notice