



Electric convection oven 1 baking element composition

F100, professional convection oven specific for pastry, bakery and gastronomy. Available with prover or stand. The electronic interface for function management is easy to use, 100 customizable programs with the possibility to manage up to 9 baking phases, automatic steam valve, adjustable and programmable vaporization for humidity management. The ventilation system with alternated air rotation ensures the perfect heat distribution. The oven door is equipped with a double tempered glass, which can be opened to facilitate cleaning operations. The stand consists of a painted metal structure, while the prover is a stainless steel cabinet, equipped with a heating thermostat and internal light. The prover can reach the maximum temperature of 65°C (150°F), whereas the baking chamber's maximum temperature is 270°C (518°F).



FUNCTIONING

- Heating by circular armored heating element
- Ventilation system by 2 alternating rotation centrifugal fan in stainless steel
- Maximum temperature reached 270°C (518°F)
- Continuous temperature monitoring with 2 thermocouples
- PID power control (Proportional Integral Derivative) can allow the automatic regulation of energy necessary on the basis of the quantity of the batch product Adaptive-Power® Technology
- Programmable electronic function management
- Vapour ducting using a motorized programmable valve

CONSTRUCTION

- Structure and baking chamber in shaped stainless steel plate
- Stainless steel door with 2 tempered glasses, the internal glass type of athermic has an easy compass opening for cleaning
- Locking handle in thermoplastic material
- Control panel on front right hand side
- Trayholder in welded stainless steel plate, extractable for cleaning
- Nebulizer injection system in stainless steel for steam production
- Thermal insulation in rock wool

ACCESSORIES

- Prover on wheels with humidifier height 800mm
- Glass prover on wheels with humidifier height 730mm
- Stand on wheels height 800mm
- Stainless steel hood with tempered silk-screened glass logo BlackBar® Design
- Hood exhauster 500m³/h
- 8-shelves trayholder
- Additional trayholder slides
- Water pressure regulator

INTERNAL DIMENSIONS

Internal depth	417 mm
Internal width	610 mm
Tray (60x40)cm	10
Space between trayholders	89 mm

STANDARD EQUIPMENT

- Color multilanguage display TFT 5"
- 100 customized programs with the possibility to program up to 9 baking steps with preheating function
- Weekly timer with the possibility to program two lightings and two power off every day
- Customized Hotkey with recurring control
- Humidity management
- USB slot for data reading/input Data-Feed™ System
- Eco-Standby™ Technology for break
- Power-Booster™ Technology for workload peaks
- Self-diagnosis with error message display
- Lighting with halogen lamps easy to replace
- Setting steaming
- Independent maximum temperature safety device

TOP VIEW

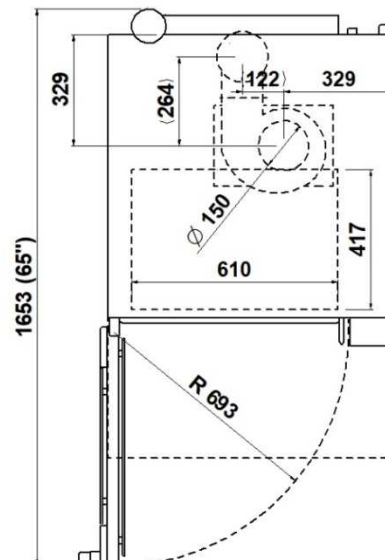

1 baking element

(assembled with prover 700mm)

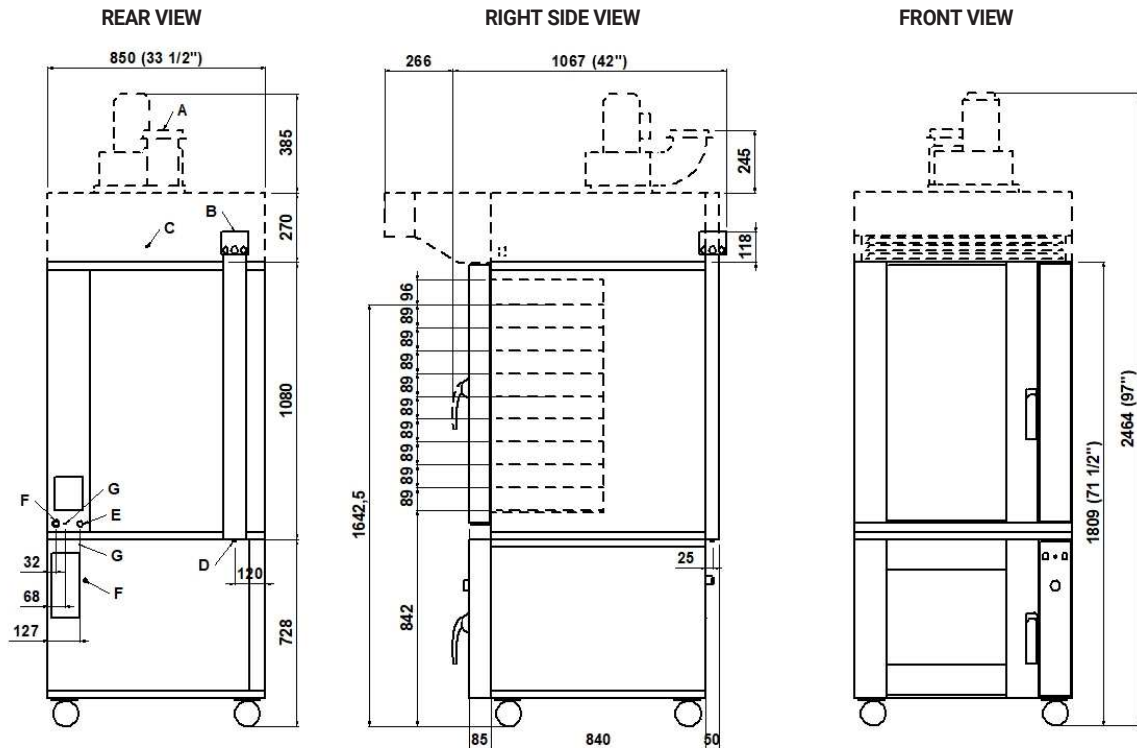

NOTE: The dimensions indicated in the views are in millimeters.

A Ø152 hood steam exhaust	B Ø INT. 102 steam exhaust	C Ø16 hood condensate exhaust	D Ø11 condensate exhaust
E 3/4" MALE water infeed	F fairleads	G M6 equipotential scw	

EXTERNAL DIMENSION

External height	1108 mm
External depth	1065 mm
External width	850 mm
Weight	145 kg

SHIPPING INFORMATION

Packed oven sizes:	
Height	1260 mm
Depth	1055 mm
Width	920 mm
Weight	(145+20) kg

FEEDING AND POWER

Standard feeding	
A.C. V400 3N	
Feeding on request	
A.C. V230 3	
Frequency	50Hz (60 Hz opz.)
Max power	18,5 kW
*Average power cons	6,1 kWh
Connection cable	
type H07RN-F	
5x6mm ² (V400 3N)	
4x10mm ² (V230 3)	
Water pressure 1-1,5 bar	
Prover feeding	
A.C. V230 1N 50/60 Hz	
Max power	1 / 1,25 kW (hu. prover)
*Average power cons	0,7 kWh
Conn. cable type H07RN-F 3x1,5mm ²	

TOTAL BAKING CAPACITY

Tray (60x40)cm	10
Space between trayholders	89mm

PROVER/STAND CAPACITY

Tray (60x40)cm	6
Space between trayholders	80mm

* This value is subject to variation according to the way in which the equipment is used
NOTE: MORETTI FORNI S.P.A. reserves the right to modify the characteristics of the products illustrated in this publication without prior notice