



Modular gas deck oven

2 decks composition

serieP gas consists of one or more independent baking chambers and an optional proofer or stand. The baking surface is made of refractory stone allowing the perfect heat distribution over the whole surface and making this oven particularly suitable for direct pizza baking, on floor or on trays. Temperature management is electronic. The oven door is hinged at the bottom, with a tempered glass window to check the product during baking. The stand consists of a painted metal structure, while the proofer is a stainless steel cabinet equipped with a heating thermostat. The proofer can reach the maximum temperature of 65°C(149°F), whereas the maximum temperature of the baking chamber is 450°C (842°F).



OPERATION

- Heating by ramp burner
- Electronic temperature management
- Protected incandescent lighter
- Flame detector
- Maximum temperature reached 450°C (842°F)
- Continuous temperatures monitoring in baking chamber by thermocouple
- Exhaust fumes B11 or B21

CONSTRUCTION

- Structure made in folded stainless steel
- Side panels in painted sheet metal
- Hood in stainless steel
- Steam duct in stainless steel plate
- Stainless steel door, tempered glass
- Handles in thermoplastic material
- Two-layer refractory brick baking surface
- Top and side structure in aluminised steel
- Rock wool heat insulation

ACCESSORIES

- Leavening proofer on wheels height 600, 800mm
- Stand with wheels height 400, 800, 950mm
- Spacer element height 300mm
- Additional tray holder guides for compartment and stand
- Activator discharge vapors
- Frontless hood

INTERNAL BAKING DIMENSIONS

Internal height	180mm
Internal depth	740mm
Internal width	1100mm
Baking surface	0,8m ²

STANDARD EQUIPMENT

- Dual halogen lighting
- Independent maximum temperature safety device

TOP VIEW

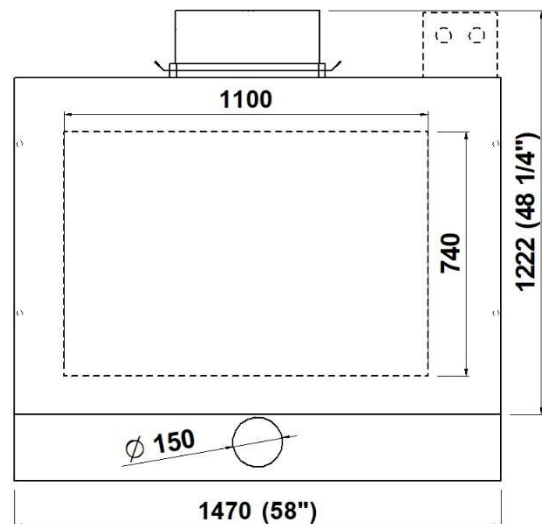

1 baking chamber height 18cm
(assembled with stand height 950mm)

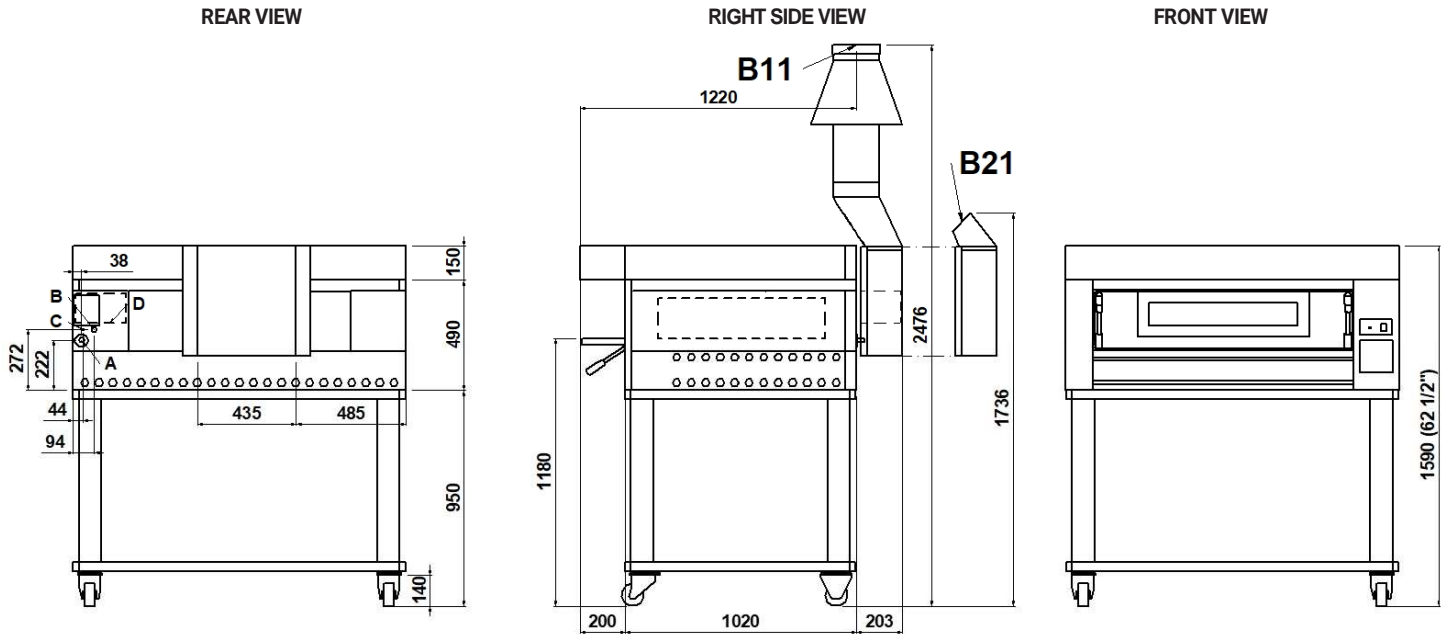

NOTE: The dimensions indicated in the views are in millimeters. **B11 DIRECT VENTILATION (ø int 207mm). B21 UNDER VENTILATION HOOD**

A 1/2" cone shaped male gas manifold	B fairleads	C M6 equipotential screws	D 120V only for UL model
---	-----------------------	--	---------------------------------------

DIMENSIONS

External height	640mm
External depth	1222mm
External width	1470mm
Weight	237kg

TOTAL BAKING CAPACITY

Tray (600x400)mm	2
Pizza diameter 300mm	6
Pizza diameter 450mm	2

SHIPPING INFORMATION

Packed in wooden crate	
Height	900mm
Depth	1730mm
Width	1660mm
Weight	(237+50)kg
When combined with leavening compartment or stand:	
Max height	1850mm
Max weight	(329+60)kg

FEEDING AND POWER

Appliance type	B11 or B21
Gas power supply	METHANE or LPG
*Consumption per hour max	
Methane G20	2,28m ³ /h
Methane G25	2,64m ³ /h
LPG G30	1,7kg/h
Electric power supply	
A.C. V230 1N	
Frequency	50/60Hz
Thermal Capacity	21,5kW
Connecting cable for each chamber type H07RN-F	
	3x2,5mm ² (V230 1N)
Power supply (optional prover)	
A.C. V230 1N 50/60 Hz	
Max power	1,5kW
*Average power cons	0,8kWh
Conn. Cable type H07RN-F	3x1,5mm ²

* This value is subject to variation according to the way in which the equipment is used
NOTE: MORETTI FORNI S.P.A. reserves the right to modify the characteristics of the products illustrated in this publication without prior notice

2 baking chambers height 18cm
(assembled with prover height 800mm)

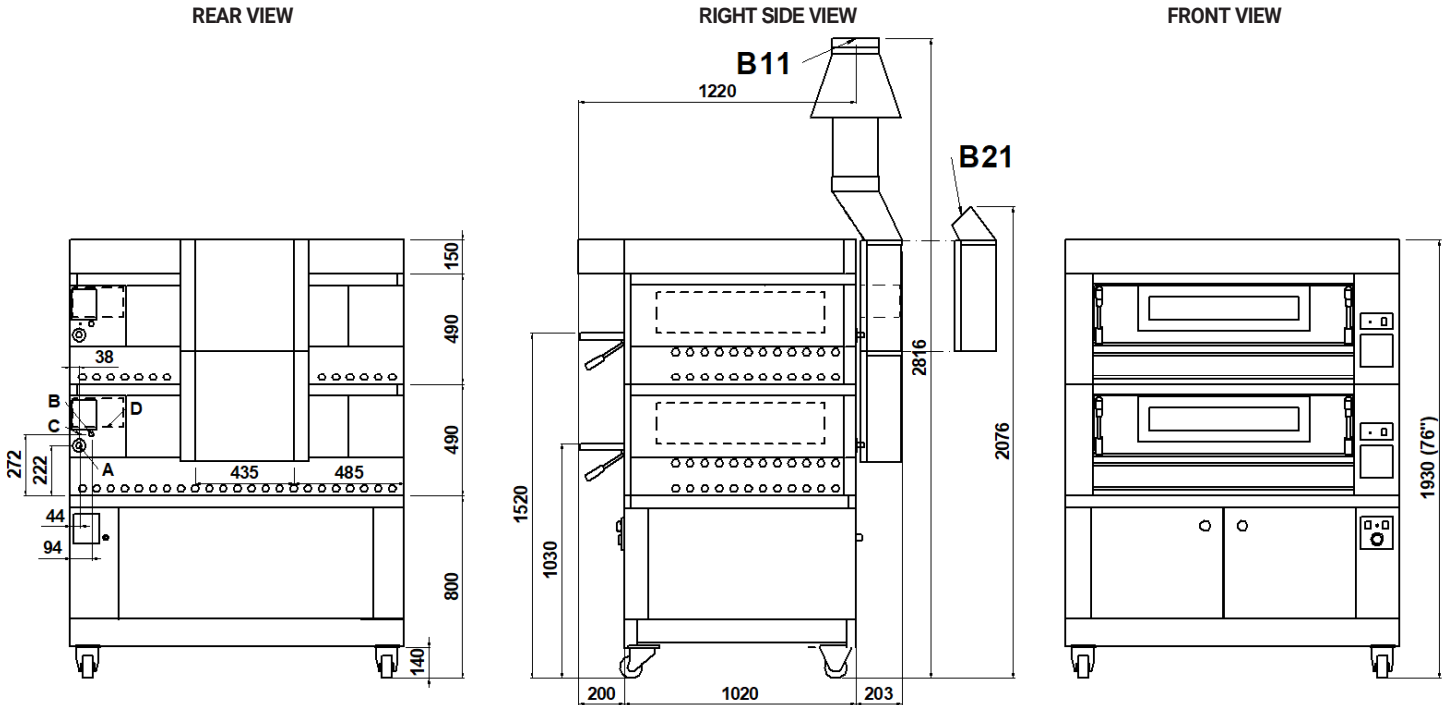

NOTE: The dimensions indicated in the views are in millimeters. **B11 DIRECT VENTILATION (ø int 207mm). B21 UNDER VENTILATION HOOD**

A	B	C	D
1/2"	fairleads	M6	120V
cone shaped male gas manifold		equipotential screws	only for UL model

DIMENSIONS

External height	1130mm
External depth	1222mm
External width	1470mm
Weight	425kg

TOTAL BAKING CAPACITY

Tray (600x400)mm	4
Pizza diameter 300mm	12
Pizza diameter 450mm	4

SHIPPING INFORMATION

Packed in wooden crate	
Height	1390mm
Depth	1730mm
Width	1660mm
Weight	(425+60)kg
When combined with leavening compartment or stand:	
Max height	2190mm
Max weight	(517+70)kg

FEEDING AND POWER

Appliance type	B11 or B21
Gas power supply	METHANE or LPG
*Consumption per hour max	
Methane G20	4,56m ³ /h
Methane G25	5,28m ³ /h
LPG G30	3,4kg/h
Electric power supply	
A.C. V230 1N	
Frequency	50/60Hz
Thermal Capacity	43kW

Connecting cable for each chamber
type H07RN-F
3x2,5mm² (V230 1N)
Power supply (optional prover)
A.C. V230 1N 50/60 Hz
Max power 1,5kW
*Average power cons 0,8kWh
Conn. Cable type H07RN-F 3x1,5mm²

* This value is subject to variation according to the way in which the equipment is used

NOTE: MORETTI FORNI S.P.A. reserves the right to modify the characteristics of the products illustrated in this publication without prior notice

3 baking chambers height 18cm
(assembled with stand height 400mm)

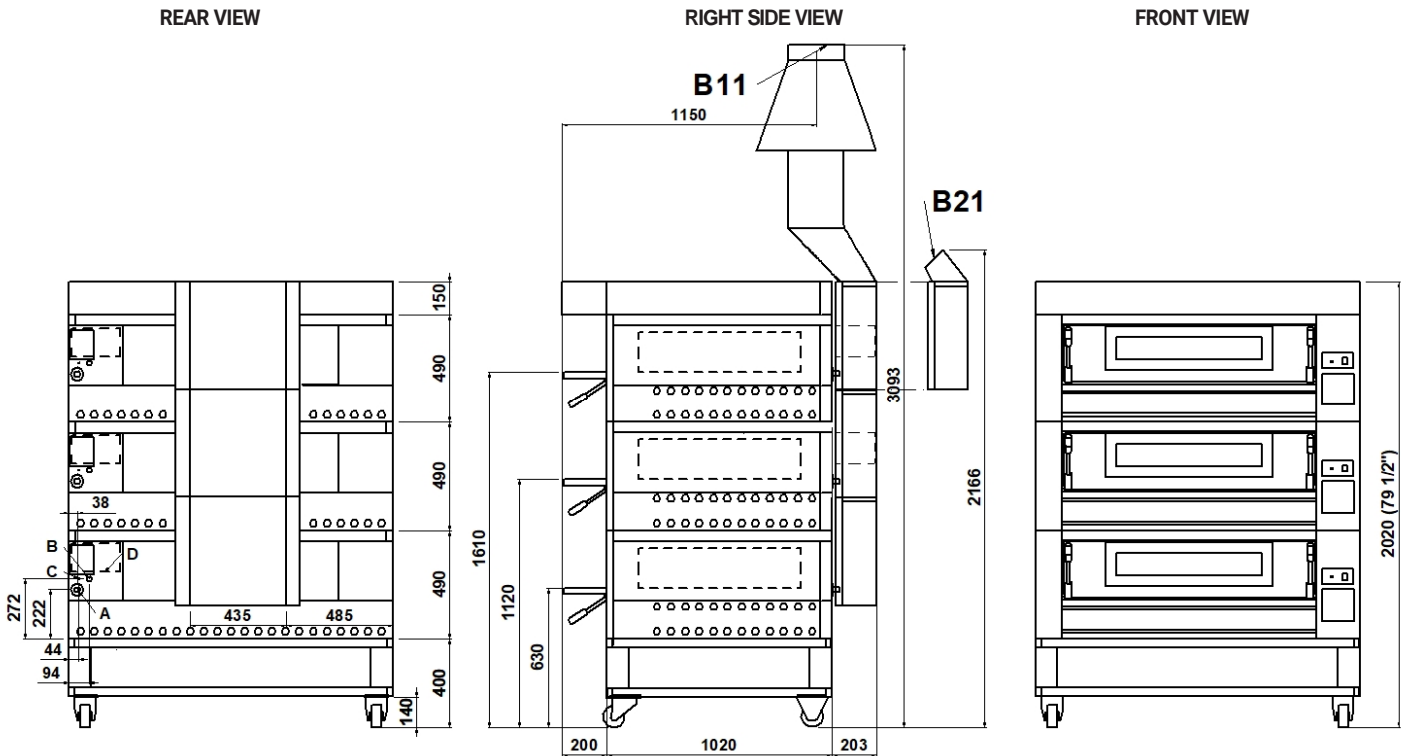

NOTE: The dimensions indicated in the views are in millimeters. **B11 DIRECT VENTILATION (ø int 254mm). B21 UNDER VENTILATION HOOD**

A 1/2" cone shaped male gas manifold	B fairleads	C M6 equipotential screws	D 120V only for UL model
---	-----------------------	--	---------------------------------------

DIMENSIONS

External height	1620mm
External depth	1222mm
External width	1470mm
Weight	625kg

TOTAL BAKING CAPACITY

Tray (600x400)mm	6
Pizza diameter 300mm	18
Pizza diameter 450mm	6

SHIPPING INFORMATION

Packed in wooden crate	
Height	1880mm
Depth	1730mm
Width	1660mm
Weight	(625+70)kg

When combined with leavening compartment or stand:	
Max height	2280mm
Max weight	(690+80)kg

FEEDING AND POWER

Appliance type B11 or B21	
Gas power supply	
METHANE or LPG	
*Consumption per hour max	
Methane G20	6,84m ³ /h
Methane G25	7,92m ³ /h
LPG G30	5,1kg/h

Electric power supply	
A.C. V230 1N	
Frequency	50/60Hz
Thermal Capacity	64,5kW

Connecting cable for each chamber type H07RN-F 3x2,5mm² (V230 1N)

Power supply (optional prover)	
A.C. V230 1N 50/60 Hz	
Max power	1,5kW
*Average power cons	0,8kWh
Conn. Cable type H07RN-F 3x1,5mm ²	

* This value is subject to variation according to the way in which the equipment is used

NOTE: MORETTI FORNI S.P.A. reserves the right to modify the characteristics of the products illustrated in this publication without prior notice

TECHNICAL DATA

ONLY FOR UL MODEL

<p>FEEDING AND POWER (EACH DECK NEEDS TO BE CONNECTED INDEPENDENTLY AND THE LOAD SHOWN BELOW ARE PER DECK)</p>	Gas power supply	NATURAL	7inWC	17,4mbar	
		LP-GAS	11inWC	27,4mbar	
		Thermal Capacity	Btu/hr	73361	
	Electric power supply	Standard feeding		A.C. V240 1ph 60Hz	
			Max power	W/DECK	300
			Ampère max	A/DECK	1,6
			Connecting cable	AWG/DECK	14
	Proofer power supply	Standard feeding		A.C. V240 1ph 60Hz	
			Max power	kW	1,8
			*Medium cons/hour	kWh	0,9
			Ampère Max	A/DECK	7,5
	Feeding on request	Baking chamber		A.C. V208 1ph 60Hz	
				A.C. V120 1ph 60Hz	
		Proofer		A.C. V208 1ph 60Hz	

* This value is subject to variation according to the way in which the equipment is used

NOTE: MORETTI FORNI S.P.A. reserves the right to modify the characteristics of the products illustrated in this publication without prior notice