



Client _____ Quantity _____
Project _____ Position _____

Levtronic 650 lt cabinet

Model: A80/1FH

Cod: A32080800101

Technical data

Max capacity:	34 trays EN60x40
Gross capacity:	573 lt
Temperature range:	-6°+40°C
Ventilation range:	25% - 100%
Humidity range:	45% - 95% with humidifier
Humidifier:	Incluso
Refrigerant unit:	Plug-In
Cooling gas:	R452A
Defrost:	Electric
Valve:	Supplied standard with solenoid
Dimensions:	810×715×2085
Packing dimensions:	905×830×2250 mm
Gross weight:	155 Kg
Voltage:	220-240 V - 50 Hz
Total rate:	1360 W
Absorbed Current:	6,2 A
Cooling capacity:	668 W*
*:	Evap. -10°C Cond. +55°C

Features

Functions:	Manual proving, retarder prover, continuous cycle, storage
Standard equipment:	20 slides for EN60x40 trays, lock with key, water drain, LED lighting
Control:	4,3" touch screen display with USB port
Doors:	1 door, self-closing with a 105° stop, right hinged
Door gasket:	Magnetic, triple chamber and easily replaceable
Insulation:	75 mm thickness - CFC/HCFC free
Exterior/interior finishing:	Exterior and interior AISI 304 stainless steel. Back, base and internal technical compartment in galvanized/ colaminated steel.
Inner corners:	Rounded for easy cleaning and ensuring maximum hygiene
Handle:	Stainless steel AISI 304, 2 mm thick
Racks and slides:	Stainless steel AISI 304
Feets:	Stainless steel AISI 304, adjustable h 100-150 mm
Cosmo:	Wi-Fi remote control system

In order to constantly offer the best possible products we reserve the right to make changes on technical specifications without incurring any obligation for equipment previously or subsequently sold.

Accessories and variants

- _____RAL customisable colouring
- _____Stainless steel evaporator
- _____Power supply frequency 60Hz
- _____Other special voltage
- _____Foot pedal kit
- _____Purity C Quell ST 50 filter cartridge
- _____Aluminium coated backing-pan EN60x40 h 20 mm
- _____Stainless steel shelf EN60x40
- _____Plastic coated shelf EN60x40
- _____Pair of type L slides 398 mm EN
- _____Serial interface, RS485 cable

COSMO - wi-fi control

Cosmo is the wi-fi technology that allow to connect, update and monitor with a smartphone the LEVTRONIC retarder prover devices. VISION is also a Cosmo hub and allow remote supervision of the Coldline devices connected to it. From the app you can check the operating conditions of each machine and receive alerts in the event of abnormal operation.

*The installation requires a kit for the replacement of the racks

Technical draw

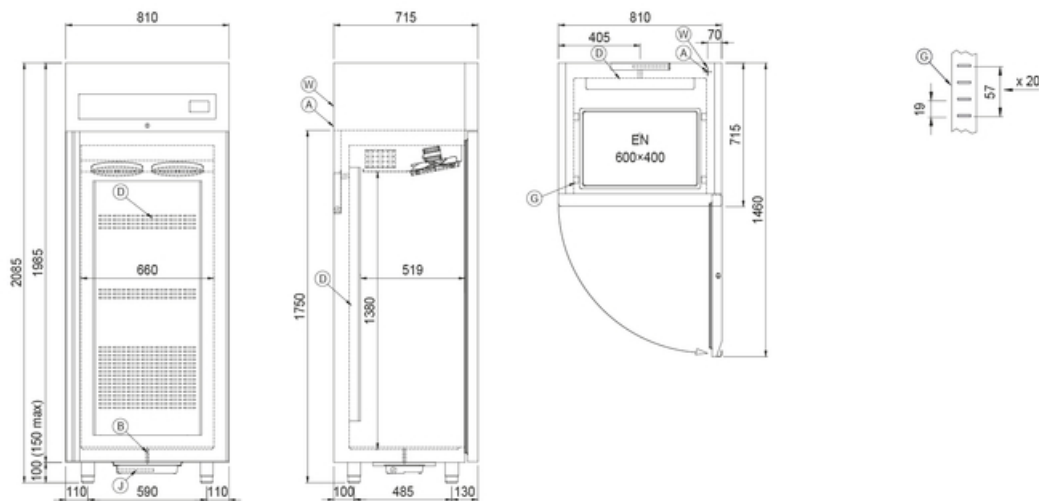

- | | | |
|-------------------------------------|---|---|
| A: Power supply cable outlet | B: Condensation water drain | D: Airflow conveyor |
| G: Racks pitch | J: Automatic evaporation of condensing water | W: Water mains connection for humidifier - 3/4" female. Unloading not required |

In order to constantly offer the best possible products we reserve the right to make changes on technical specifications without incurring any obligation for equipment previously or subsequently sold.