

**Modular Cooking Range Line
 thermaline 90 - 40 lt Well Freestanding
 Electric Pasta Cooker, 1 Side, H=800**

ITEM # _____

MODEL # _____

NAME # _____

SIS # _____

AIA # _____



589449 (MCKEFADDAO) 40lt electric Pasta Cooker,
 one-side operated

Short Form Specification

Item No. _____

Unit constructed according to DIN 18860_2 with 20 mm drop nose top and 70 mm recessed plinth. Internal frame for heavy duty sturdiness in stainless steel. 2 mm top in 1.4301 (AISI 304). Flat surface construction, easily cleanable. THERMODUL connection system enables seamless worktop when units are connected and avoids soil penetrating. Appliance which can also be used to cook noodles of every kind, rice, dumplings and vegetables. Water basin in 1.4435 (AISI 316L) stainless steel, with automatic constant water level re-fill and water temperature regulation via sensors. Integrated drip tray to drain baskets. Compatible with automatic basket lifting system to facilitate lifting operations. Safety systems and automatic low-water level shut-off protect against overheating. All-round basin raised edges to protect against soil infiltration. Standby function saves energy and quickly recovers maximum power. Metal knobs with embedded hygienic silicon "soft" grip enable easier handling and cleaning. IPX5 water resistant certification.

Configuration: Freestanding, One-side operated.

Main Features

- All major components may be easily accessed from the front.
- THERMODUL connection system creates a seamless work top when units are connected to each other thus avoiding soil penetrating vital components and facilitating the removal of units in case of replacement or service.
- Metal knobs with embedded hygienic silicon "soft" grip for easier handling and cleaning. The special design of the controls prevent infiltration of liquids or soil into vital components.
- Constant water level refill.
- Automatic low-water level shut-off: no accidental over-heating.
- Provided with integrated drip zone on which baskets can be placed for draining purposes.
- In addition to cooking pasta, the appliance can be used for noodles of every kind, rice, dumplings and vegetables.
- IPX5 water resistance certification.
- Easy to clean basin with rounded corners.
- Large visible digital display manufactured in tempered glass to resist heat and chemicals, showing temperatures or power settings. The display also shows on/off status of the appliance and on/off status of the heating elements.
- Standby function for energy saving and fast recovery of maximum power.
- Raised edge all around the well to protect from infiltration of dirt from worktop.
- Safety systems protect against overtemperature and can be manually reset.
- Automatic two-speed water refill regulated by water level sensor at maximum or minimum volume.
- Water temperature controlled by electronic sensor and can be selected as either temperature or power levels.
- Possibility of food re-generation thanks to electronic temperature control.

Construction

- 2 mm top in 1.4301 (AISI 304).
- Unit constructed according to DIN 18860_2 with 20 mm drop nose top and 70 mm recessed plinth.
- Flat surface construction with minimal hidden areas to easily clean all surfaces
- Water basin in 1.4435 (AISI 316L) stainless steel is seamlessly welded into the top of the appliance.
- Internal frame for heavy duty sturdiness in

APPROVAL: _____

stainless steel.



Front

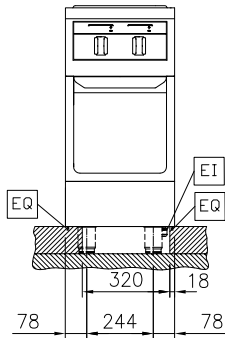

Side

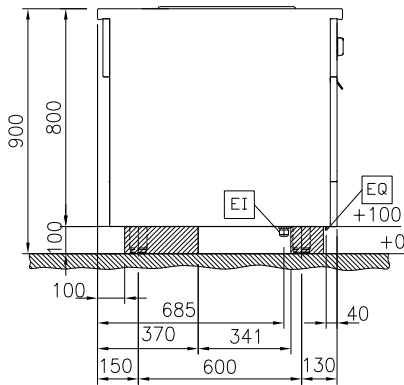

D = Drain
 EI = Electrical inlet (power)
 EQ = Equipotential screw
 WI = Water inlet

Top

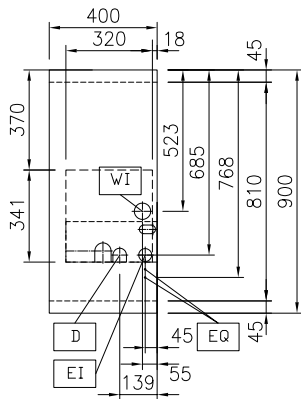

Electric

Supply voltage:
 589449 (MCKEFADDAO) 400 V/3N ph/50/60 Hz
 Current consumption: 14.4 Amps
 Total Watts: 10 kW

Water:

Incoming Cold/hot Water line size: 3/4"
 Drain line size: 1"

Key Information:

| | |
|----------------------------------|---------------------------|
| Configuration: | On Base;One-Side Operated |
| Number of wells: | 1 |
| Usable well dimensions (width): | 300 mm |
| Usable well dimensions (height): | 320 mm |
| Usable well dimensions (depth): | 515 mm |
| Well capacity: | 38 It MIN; 40 It MAX |
| Thermostat Range: | 40 °C MIN; 90 °C MAX |
| External dimensions, Width: | 400 mm |
| External dimensions, Depth: | 900 mm |
| External dimensions, Height: | 800 mm |
| Net weight: | 70 kg |

Optional Accessories

- | | | | | | |
|--|------------|--------------------------|---|------------|--------------------------|
| • Connecting rail kit, 900mm | PNC 912502 | <input type="checkbox"/> | • Endrail kit (12.5mm) for thermaline 90 units, right | PNC 913203 | <input type="checkbox"/> |
| • Stainless steel side panel, 900x800mm, freestanding | PNC 912511 | <input type="checkbox"/> | • Stainless steel side panel, left, H=800, flush | PNC 913224 | <input type="checkbox"/> |
| • Portioning shelf, 400mm width | PNC 912522 | <input type="checkbox"/> | • Stainless steel side panel, left, H=800, flush | PNC 913225 | <input type="checkbox"/> |
| • Portioning shelf, 400mm width | PNC 912552 | <input type="checkbox"/> | • T-connection rail for back-to-back installations without backsplash | PNC 913227 | <input type="checkbox"/> |
| • Folding shelf, 300x900mm | PNC 912581 | <input type="checkbox"/> | • Insert profile d=900 | PNC 913232 | <input type="checkbox"/> |
| • Folding shelf, 400x900mm | PNC 912582 | <input type="checkbox"/> | • Energy optimizer kit 18A - factory fitted | PNC 913245 | <input type="checkbox"/> |
| • Fixed side shelf, 200x900mm | PNC 912589 | <input type="checkbox"/> | • Endrail kit, (12.5mm), for back-to-back installation, left | PNC 913251 | <input type="checkbox"/> |
| • Fixed side shelf, 300x900mm | PNC 912590 | <input type="checkbox"/> | • Endrail kit, (12.5mm), for back-to-back installation, right | PNC 913252 | <input type="checkbox"/> |
| • Fixed side shelf, 400x900mm | PNC 912591 | <input type="checkbox"/> | • Endrail kit, flush-fitting, for back-to-back installation, left | PNC 913255 | <input type="checkbox"/> |
| • Stainless steel front kicking strip, 400mm width | PNC 912594 | <input type="checkbox"/> | • Endrail kit, flush-fitting, for back-to-back installation, right | PNC 913256 | <input type="checkbox"/> |
| • Stainless steel side kicking strips left and right, freestanding, 900mm width | PNC 912621 | <input type="checkbox"/> | • Side reinforced panel only in combination with side shelf, for freestanding units | PNC 913259 | <input type="checkbox"/> |
| • Stainless steel side kicking strips left and right, back-to-back, 1810mm width | PNC 912627 | <input type="checkbox"/> | • Side reinforced panel only in combination with side shelf, for back-to-back installations, left | PNC 913277 | <input type="checkbox"/> |
| • Stainless steel plinth, freestanding, 400mm width | PNC 912916 | <input type="checkbox"/> | • Side reinforced panel only in combination with side shelf, for back-to-back installation, right | PNC 913278 | <input type="checkbox"/> |
| • Connecting rail kit: modular 90 (on the left) to ProThermetic tilting (on the right), ProThermetic stationary (on the left) to ProThermetic tilting (on the right) | PNC 912975 | <input type="checkbox"/> | • Filter W=400mm | PNC 913663 | <input type="checkbox"/> |
| • Connecting rail kit: modular 80 (on the right) to ProThermetic tilting (on the left), ProThermetic stationary (on the right) to ProThermetic tilting (on the left) | PNC 912976 | <input type="checkbox"/> | • Stainless steel dividing panel, 900x800mm, (it should only be used between Electrolux Professional thermaline Modular 90 and thermaline C90) | PNC 913673 | <input type="checkbox"/> |
| • Endrail kit, flush-fitting, left | PNC 913111 | <input type="checkbox"/> | • Electric mains switch 25A 4mm ² NM for modular H800 electric units (factory fitted) | PNC 913676 | <input type="checkbox"/> |
| • Endrail kit, flush-fitting, right | PNC 913112 | <input type="checkbox"/> | • Stainless steel side panel, 900x800mm, flush-fitting (it should only be used against the wall, against a niche and in between Electrolux Professional thermaline and ProThermetic appliances and external appliances - provided that these have at least the same dimensions) | PNC 913689 | <input type="checkbox"/> |
| • 3 ergonomic baskets for 40lt pasta cooker | PNC 913124 | <input type="checkbox"/> | | | |
| • 1 square basket for 40lt pasta cooker | PNC 913125 | <input type="checkbox"/> | | | |
| • 1 ergonomic basket for 40lt pasta cooker | PNC 913126 | <input type="checkbox"/> | | | |
| • False bottom for 40lt pasta cooker basket | PNC 913127 | <input type="checkbox"/> | | | |
| • 3 baskets 1/3 GN for 40lt pasta cooker | PNC 913128 | <input type="checkbox"/> | | | |
| • 2 baskets 1/2 GN for 40lt pasta cooker | PNC 913129 | <input type="checkbox"/> | | | |
| • 3 round baskets for 40lt pasta cooker | PNC 913130 | <input type="checkbox"/> | | | |
| • 6 round baskets for 40lt pasta cooker | PNC 913131 | <input type="checkbox"/> | | | |
| • Grid support for round baskets | PNC 913132 | <input type="checkbox"/> | | | |
| • Support frame for 6 round baskets | PNC 913133 | <input type="checkbox"/> | | | |
| • 1 basket 1/1 GN for 40lt pasta cooker | PNC 913134 | <input type="checkbox"/> | | | |
| • Lid for 40lt pasta cooker | PNC 913149 | <input type="checkbox"/> | | | |
| • Endrail kit (12.5mm) for thermaline 90 units, left | PNC 913202 | <input type="checkbox"/> | | | |