

ADVANTAGES

- ✓ VEGETABLE SLICER 1100 W.
- ✓ VOLTAGE 220 - 240 V / SINGLE-PHASED.
- ✓ 1 FIXED SPEED : 320 RPM.
- ✓ STAINLESS STEEL PUSHER HANDLE.
- ✓ DELIVERED WITHOUT DISC.

- French design and manufacture, guaranteed quality, robustness and reparability - The DYNAMIC vegetable slicer is easily disassembled, repairable and reassembled. DYNAMIC guarantees the immediate availability of spare parts.
- Thanks to its unique design, this is an extremely versatile and aesthetic device. The design is based on users' real needs: the use of first quality materials (stainless steel), thought-out ergonomics, details and tips guaranteeing hygiene and safety (patent pending).
- A product designed with sustainable development in mind – 80% of the materials used are made from stainless steel and aluminium.

DESCRIPTION



- Universal vegetable slicer with a large choice of stainless steel discs. All parts in contact with food are easily removable and dishwasher-proof for quick cleaning: cutting chamber, pusher, hopper and pusher handle. Thought-out ergonomics, the device is designed to be used by both left- and right-handed.
- Two hoppers to adapt to all types of vegetables: a wide hopper of 217 cm² for bulky vegetables such as cabbage, celeriac and a cylindrical hopper of Ø 60.5 mm for long and delicate vegetables (zucchinis, cucumbers). A side food chute with a 20 cm passage to install a deep GN collection container (20 cm).
- An induction motor, integrated in the metal motor block, with a power of 1100 W and a single-phased power supply of 220 - 240 V. Easy-to-use control panel.
- Magnetic detection which prevents the appliance from starting if an anomaly is detected. The appliance stops as soon as it detects any type of inappropriate use.
- Optional stainless steel discs, dishwasher-proof.

MAIN CHARACTERISTICS

- Capacity up to 300 kg/h, suitable for as much as 400 covers per service.
- Capable of grating, slicing, cutting fruits and vegetables.
- Ergonomic, ambidextrous, stainless steel pusher handle.
- All parts in contact with food are removable without tools and are dishwasher-proof.
- Very practical side disposal, without projection, enabling the use of deep collection containers.
- Automatic start with pusher-handle.
- Automatic magnetic detection for total operator safety.
- Wide choice of stainless steel discs with a diameter of 225 mm (optional).

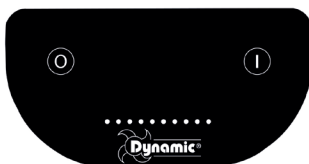

1 FIXED SPEED CONTROL PANEL

CONSTRUCTION

- An induction motor, integrated in the motor block, ensuring robustness and reliability over time.
- Integrated air vents on the motor unit for good engine ventilation.
- Extremely solid base.
- POWER : 1100 W.
- VOLTAGE : 220 - 240 V / SINGLE-PHASE.
- 1 FIXED SPEED : 320 Rpm.
- Easy and quick to dismantle accessories without tools (patent pending).

OPTIONAL ACCESSORIES VEGETABLE SLICER MODE



SLICING DISC

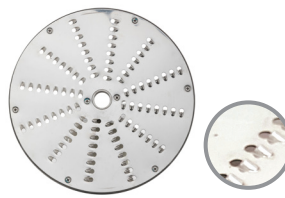

GRATING DISC



JULIENNE DISC

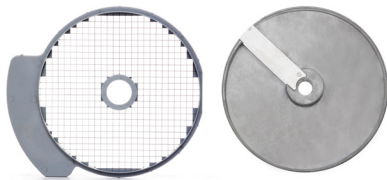

DICING KIT

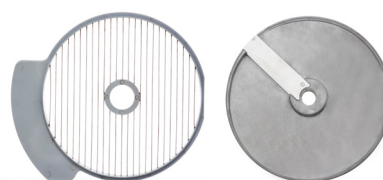

FRENCH FRIES KIT

- **CL1005** 0,5MM SLICING DISC
- **CL1015** 1,5MM SLICING DISC
- **CL1025** 2,5MM SLICING DISC
- **CL1030** 3MM SLICING DISC
- **CL1040** 4MM SLICING DISC
- **CL1050** 5MM SLICING DISC
- **CL1070** 7MM SLICING DISC
- **CL1080** 8MM SLICING DISC
- **CL1090** 9MM SLICING DISC
- **CL1110** 11MM SLICING DISC
- **CL1120** 12MM SLICING DISC
- **CL1130** 13MM SLICING DISC

- **CL2002** 2MM GRATING DISC
- **CL2003** 3MM GRATING DISC

- **CL2005** 5MM GRATING DISC
- **CL2009** 9MM GRATING DISC

- **CL3032** 3X2MM JULIENNE DISC
- **CL3042** 4X2MM JULIENNE DISC
- **CL3044** 4X4MM JULIENNE DISC
- **CL3055** 5X5MM JULIENNE DISC
- **CL3052** 5X2MM JULIENNE DISC
- **CL3088** 8X8MM JULIENNE DISC

- **CL4008** DICING KIT 8X8MM

- **CL5008** FRENCH FRIES KIT 8X8MM

TECHNICAL SPECIFICATIONS

FRONT

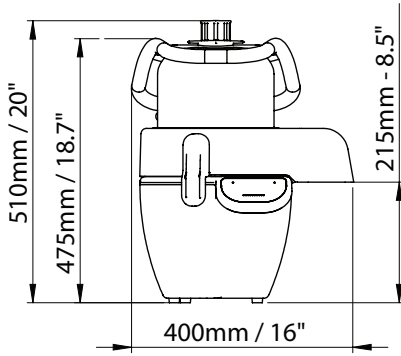

SIDE

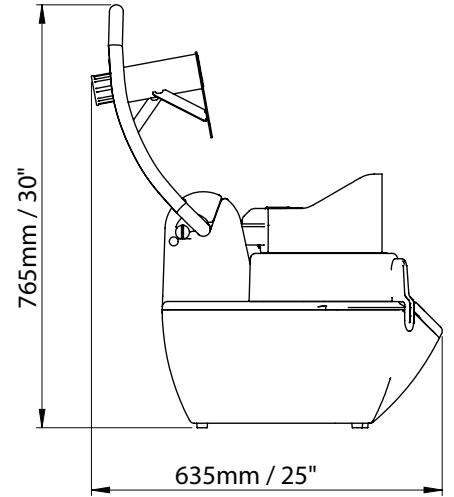
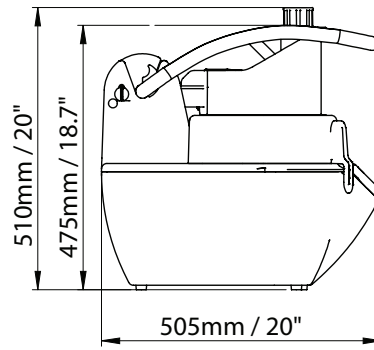

TOP

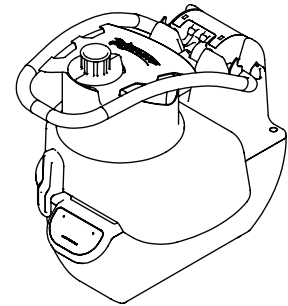
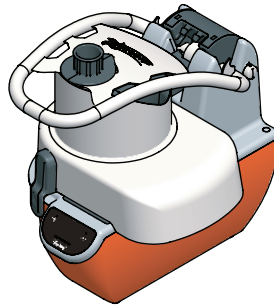
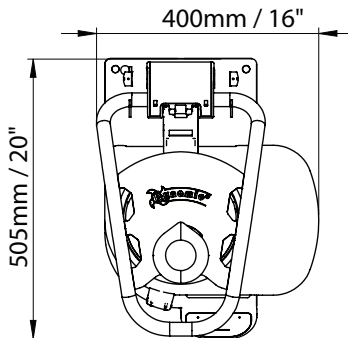

ELECTRICAL FEATURES

VOLTAGE	220 - 240 V / 50 - 60 Hz
POWER	1100 W

GENERAL INFORMATION

WIDTH	400 mm
HEIGHT	475 mm
DEPTH	505 mm