



Combined Rotisserie Oven & Self-Service Display

Product Advantages:

Oven

- Multidirectional ventilated infrared cooking.
- Through view thanks to front and rear windows.
- Digital thermostat and automatic stop at the end of cooking.
- Switching to "temperature maintenance" mode .

Display

- Mobility ensured by 4 wheels including 2 with brakes
- Right and left side windows for a panoramic view
- 2 stainless steel shelves including 1 upper recessed

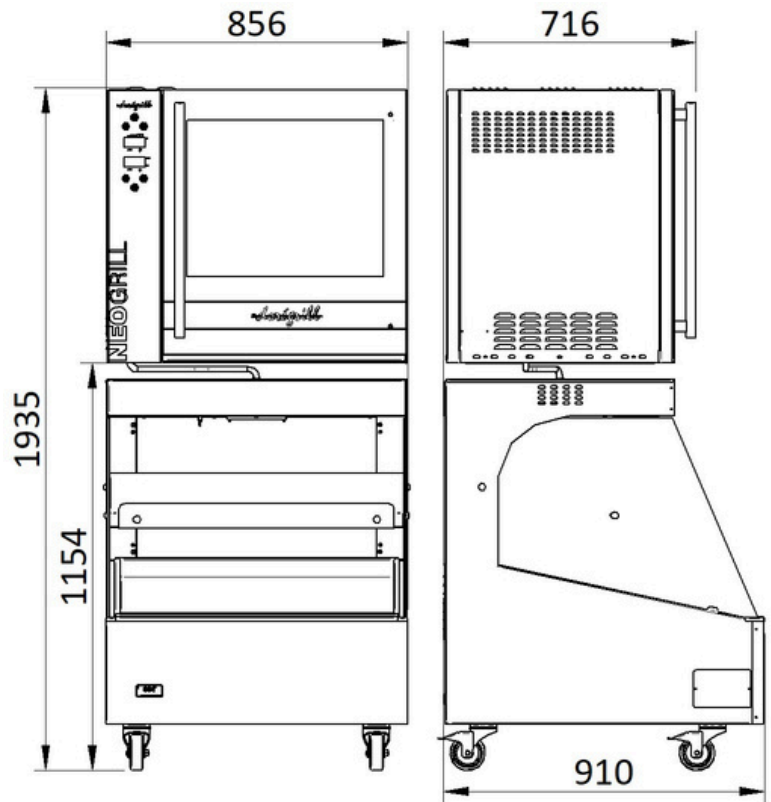

Installation requirements:

- Electrical power provided by customer.



Technical Data:

Length	856 mm
Height	1935 mm
Depth	910 mm
Nb of baskets	4
Voltage	415 V + N + T
Amperage	15 A
Average power consumption	5 kWh
Punctual instant consumption	7.8 kW
Capacity per hour	16 Poultry (depending on weight)
Weight	220 kg

