

Spit roast rotisserie oven

Product Advantages:

- Traditional Rotisserie with powerful lighting system.
- Porcelain Enamel finish with choice of colour available.
- Decorative roof with lighted rotisserie sign.
- Porcelain enamel finish and individual burners provide the best cooking system for poultry.
- Fast and consistent from 30 to 36 chicken capacity.
- The unique individual burner system provides exceptional control and unmatched durability.
- The porcelain enamel guarantees a non-stick, most durable surface.
- Enamelled panels.
- 6 spits.
- Each individual spits has its own unique burner for constant and fast cooking time. Adjustable spits allow to cook any type of products from chicken to turkey, lamb, beef and vegetables.
- A variety of attachments are also available such as basket spits and chicken spits
- Our rotisserie ingenious spit adjustment guarantees a perfect cooking regardless of the size of the product.
- Individual motors

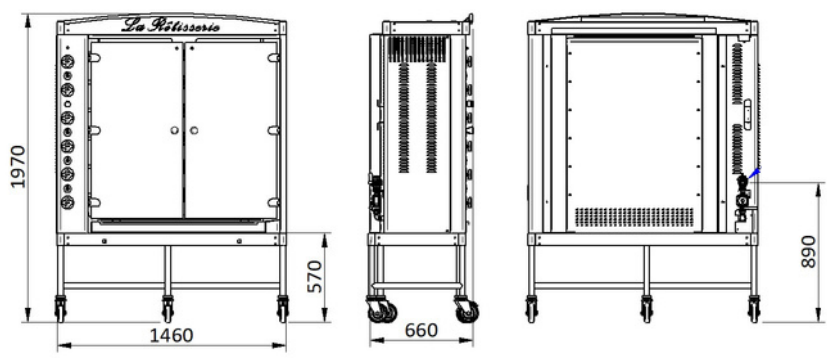

Installation requirements:

- Electrical power provided by customer.

Technical Data:

- Clearance: 15cm on the right, left and rear side
- Connected load: 117Mj/h 240V single phase – 10A

