

Basket Roast Rotisserie Oven

Product Advantages:

- Scenario cleaning program with washing arms. Detergent and cold water.
- Incomparable cooking results thanks to the programs (SmartCookingFunction®) by association of hot pulsed air and direct infrared.
- Benefits from the internal program (IRegulControl®). Save energy and gain profitability.

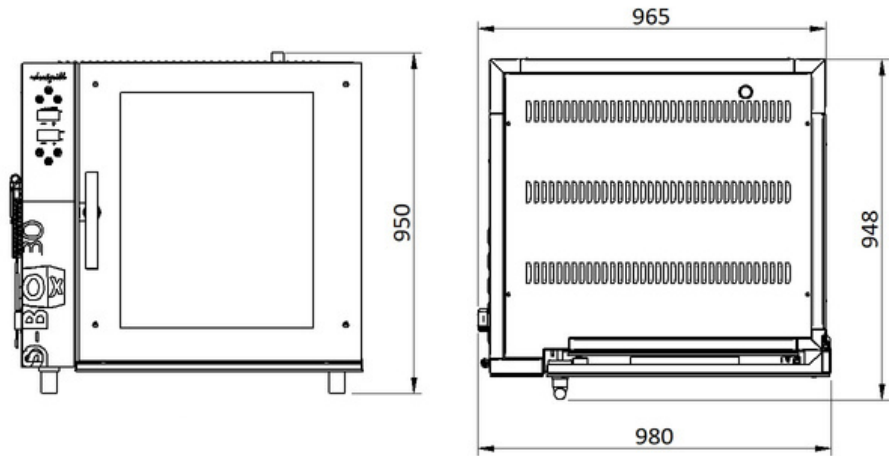

Installation requirements:

- Electrical power provided by customer.



Technical Data:

Length	980 mm
Height	950 mm
Depth	948 mm
Nb of baskets	4
Voltage	415 V+N+T 3 phase
Amperage	14 A
Average power consumption	4.7 kWh
Punctual instant consumption	9.4 kW
Capacity per hour	16 Vol (depending on weight)

