

Daub Bakery Machinery B.V.	Manual Date: 01-04-2007 Version: 04
BREADSLICER 208	English

INDUSTRY KITCHENS

www.industrykitchens.com.au 1800 611 058

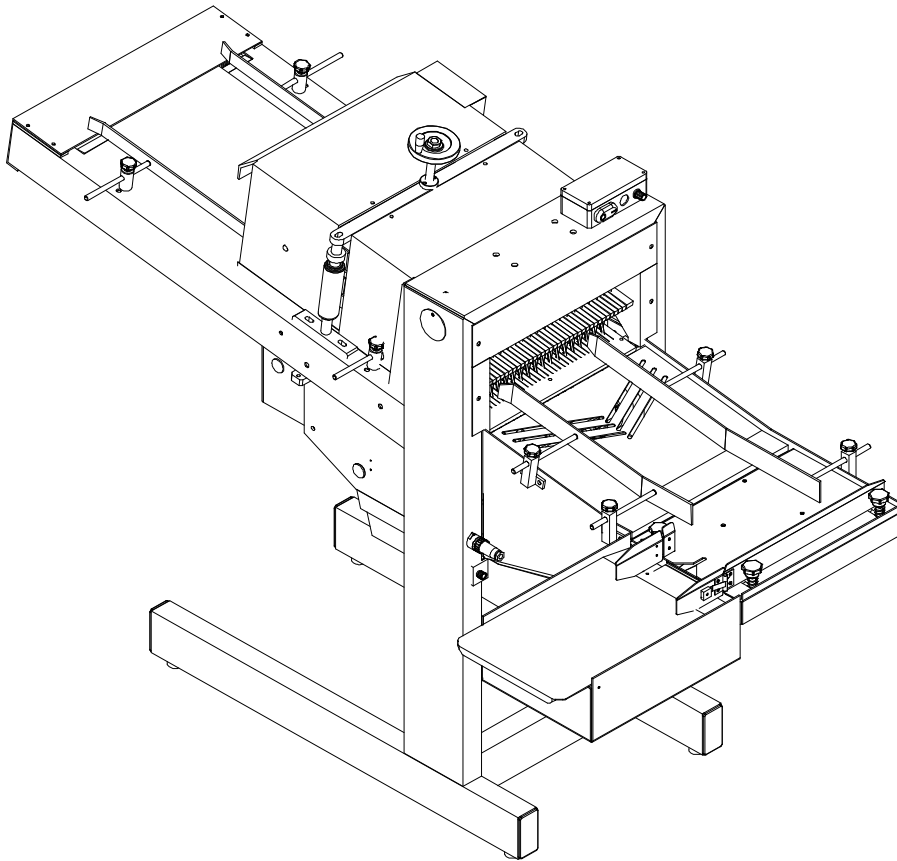

Daub Bakery Machinery B.V.	Manual Date: 01-04-2007 Version: 04
BREADSLICER 208	Page 2

1	GENERAL.....	3
2	PRODUCT INFORMATION	4
3	NOTIONS	5
3.1	Warnings.....	5
3.2	Qualified employees.....	5
3.3	Description of parts of the machine	6
3.4	Error notifications on diplay freq.converter	6
4	SAFETY.....	7
4.1	Safety regulations	7
4.2	Dangers because of mechanical components.....	7
4.3	Dangers because of electrical components.....	7
4.4	Dangers because of lack of hygiene.....	8
5	TRANSPORT AND UNPACKING	8
5.1	Transport	8
5.2	Unpacking.....	8
6	INSTALLATION	9
6.1	Placing and maintenance.....	9
6.2	Conditions.....	9
6.3	Electrical connection	9
6.4	Carrying off material.....	10
6.5	Taking out of operation	10
7	PRODUCT DESCRIPTION.....	11
7.1	Purpose of the machine	11
7.2	Inadmissible use of the machine.....	11
7.3	Description of the control panel.....	12
7.4	Working of the control panel.....	12
7.5	Taking in use of the machine	13
8	WORKING WITH THE MACHINE	14
9	MAINTENANCE	15
9.1	Cleaning.....	15
9.2	Maintenance	15
9.3	Instructions changing infeed belt.....	16
9.4	Instructions changing knives	16
10	OILLUBRICATION OF THE KNIVES (OPTIONAL).....	19
10.1	Adjustment of the oil quantity	19
11	FAULT FINDING	20
12	FIGURES AND DIAGRAMS	21
13	PART LIST	31

Daub Bakery Machinery B.V.	Manual Date: 01-04-2007 Version: 04
BREADSLICER 208	Page 3

1 GENERAL

It is important to read this manual and to comply with the suggestions and / or regulations when unpacking, installing, using and maintaining the machine. If the machine is sold, this manual should be handed over to the new owner.

Employees who have been instructed concerning the use of it and who have read this manual may only operate the machine.

The guarantee obligation of Daub Bakery Machinery B.V. is only valid for defects which have occurred in spite of a good use of the machine, such as described in this manual. Daub Bakery Machinery B.V. can never be held responsible for damage or injuries to persons, if these are caused by inaccurate use of the machine.

No part of this publication may be reproduced, multiplied or distributed without the prior written permission of the manufacturer.

Daub Bakery Machinery B.V. can not be held responsible for mistakes and / or misprints in this manual.

Daub Bakery Machinery B.V.	Manual Date: 01-04-2007 Version: 04
BREADSLICER 208	Page 4

2 PRODUCT INFORMATION

Manufacturer: Daub Bakery Machinery B.V.
Nieuwkerksedijk 10
5051 HT Goirle
P.O. box 51
5050 AB Goirle
The Netherlands
Tel: +31 13 5308700
Fax: +31 13 5308729

After sales service: Your supplier

Machine naming: BREADSLICER 208
Machine number: see machine plate
Date of manufacturing: see machine plate
Power: see machine plate
Voltage: see machine plate
Current: see machine plate
Weight: 240-260 kg
Sound: <65 dB(A)

Possible executions:

Voltage: 3*400 V/50 Hz+N, 3*230 V/50 Hz, 3*440V/60Hz+N, 3*230 V/60 Hz
Other voltages on request

Technical information:

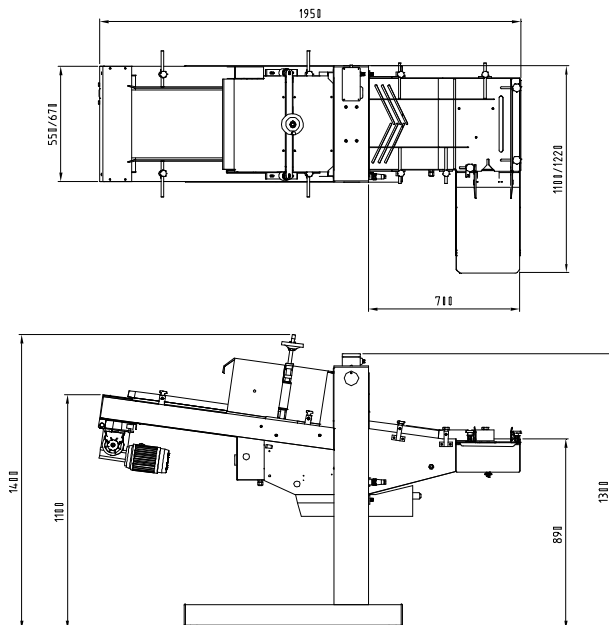

Depending the execution of the slicer a maximum width of the bread can be 40 cm or 52 cm

Options:

- Electronic oil lubrication of the knives
- Four wheels

Daub Bakery Machinery B.V.	Manual Date: 01-04-2007 Version: 04
BREADSLICER 208	Page 5

3 NOTIONS

3.1 Warnings

The following signs warn the operator for a possible danger because of mechanical or electrical components.



Figure 3-1

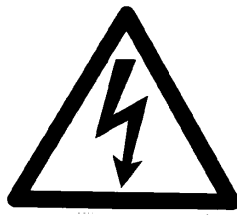

Figure 3-2

Figure 3.1 is a sticker which is used on the machine indicating the sharpness of the knives. Do not come near the knives when machine is running.

Figure 3.2 is a sticker which is used on the machine indicating where electrical power is present.

Before taking in use the machine, you should carefully read this manual and follow the instructions. Make sure that the warning stickers stay in good condition, and if necessary replace them. When you use the machine for the first time, follow the instructions in this manual carefully, so that you will not be surprised.

Do not allow unqualified employees to operate the machine.



Only qualified employees may operate the machine.



Be sure the machine is switched off during cleaning, maintenance and lubrication.

After maintenance of the machine do not forget to replace the safety covers, crumbtray and the lid of the switchbox.

Qualified employees must do all repairs, mechanical as well as electrical.

3.2 Qualified employees

We herewith mean:

Persons who are familiar with the installation, mounting, taking in use, working of the machine and who have the right qualifications.

Daub Bakery Machinery B.V.	Manual Date: 01-04-2007 Version: 04
BREADSLICER 208	Page 6

3.3 Description of parts of the machine

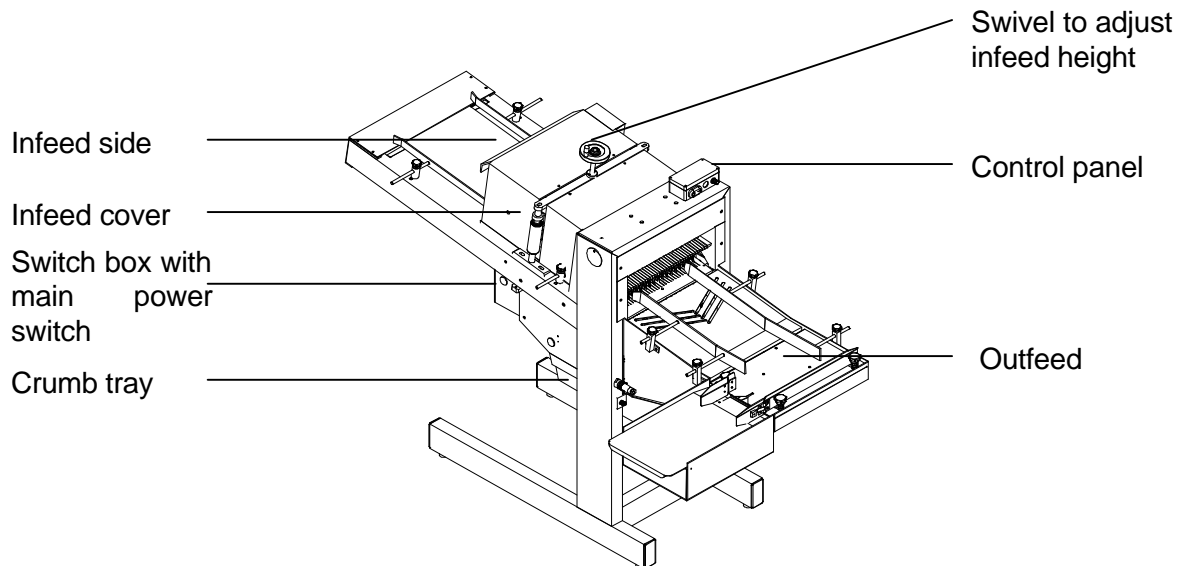

Figuur 3-3

3.4 Error notifications on display freq.converter

The display can show the following faults:

E05. OVERLOAD -> TOO MUCH LOAD OR TOO HIGH SPEED OR BLUND KNIVES

E14. ground fault -> GROUND NOT CONNECTED CORRECTLY, MACHINE CAN BE UNDER VOLTAGE



Do not use the machine when E-notifications appears. Read first more information in the supplied manual on the CD about the freq.converter which can be found in the switch box.

Daub Bakery Machinery B.V.	Manual Date: 01-04-2007 Version: 04
BREADSLICER 208	Page 7

4 SAFETY

4.1 Safety regulations



Remove plug from the power supply when cleaning and/or maintaining the machine.



Only qualified or well instructed employees can do repairs of mechanical or electrical nature.



Never put your hands into the infeed cover



Keep covers placed when operating the machine.



Do not use the machine when certain notifications (mentioned in chapter 3.4) appear in the display. Read more about the error and what to do!

4.2 Dangers because of mechanical components.



Safety covers protect all parts. Keep the covers on during normal operation closed



When maintaining the machine and especially when removing parts without respecting standard safety regulations, you might get injured when not carefull.



During cleaning be sure the power plug is not connected to a power supply

By proper use of the machine as described in chapter 8 no dangers will occur.

4.3 Dangers because of electrical components.



Please keep the boxes closed when machines is still connected to a power suply
Do not use the machine when certain notifications (mentioned in chapter 3.4) appear in the display. Read more about the error and what to do!



Broken or damaged cables and electrical componements should be replaced immediatly by an electricien.

Daub Bakery Machinery B.V.	Manual Date: 01-04-2007 Version: 04
BREADSLICER 208	Page 8

4.4 Dangers because of lack of hygiene.

These dangers could occur if the measures, as described in chapter 11 "Maintenance", will not be followed up.

5 TRANSPORT AND UNPACKING

5.1 Transport

The machine must be transported in its original packing. In the means of transport the packing must be secured against shoving. The machine should be moved with the right lift equipment.

Transport damage caused by not having followed above-mentioned regulations can not be claimed. Moreover transport of goods is always at the buyers risk, unless explicitly agreed otherwise.



Do not load anything on the top of the packing.



The machine should always be transported upright.

5.2 Unpacking

Leave the packing upright

Unpack the machine carefully and check if there are signs of transportation damages. Should you find any, please inform the transport agent immediately. We advise you to take photographs of the damage.

Remove the machine from the pallet by means of a lift truck or other lift equipment.

By shoving the arms of the lift truck under the foot of the machine, it can be taken from the pallet



Weight of the machine is approximately 280 kgs.

Out of safety considerations it is advisable to keep enough distance when lifting the machine.

Daub Bakery Machinery B.V.	Manual Date: 01-04-2007 Version: 04
BREADSLICER 208	Page 9

6 INSTALLATION

6.1 Placing and maintenance



Only qualified employees are allowed to install the machine.



The machine can only be used for its purpose: to slice bread products.



Guarantee can not be claimed if changes have been made to the machine without the manufacturers permission and/or if not-original spare parts are used. The use of not-original spare parts can damage the machine and/or harm the operator.

The machine should be placed on a solid and flat floor. The machine can be levelled by adjusting the height of the feet.

6.2 Conditions

Temperature: 15° C till 40° C
Relative humidity: 20% till 95%

6.3 Electrical connection

A qualified engineer must carry out the installation and an electrician should connect the machine to the main supply. Always check first if the voltage and phases of the electrical connection are in accordance with those of the machine (see machine plate). If this is not the case, please contact your supplier. Be aware the machine contains an electronic frequency converter, so stabilized power supply is needed as well recommendable the power supply is galvanic separated.

Daub Bakery Machinery B.V.	Manual Date: 01-04-2007 Version: 04
BREADSLICER 208	Page 10

6.4 Carrying off material

When carrying off a complete machine, parts or only the packing, you should comply with the legal regulations. Specifications concerning the material of the parts can be asked for at the manufacturers.



Correct disposal of this product

This marking shown on the product or its literature indicates that it should not be disposed with other household wastes at the end of its working life. To prevent possible harm to the environment or human health from uncontrolled waste disposal, please separate this from other types of wastes and recycle it responsibly to promote the sustainable reuse of material resources.

Household users should contact either the retailer where they purchased this product, or their local government office, for details of where and how they can take this item for environmentally safe recycling.

Business users should contact their supplier and check the terms and conditions of the purchase contract. This product should not be mixed with other commercial wastes for disposal.

6.5 Taking out of operation

Switch off the machine by turning the main switch to "0".
Then clean it and check the lubrication points as described in chapter 11 "Maintenance".
Protect the machine for influences from outside and store it in a dry and closed room.

Daub Bakery Machinery B.V.	Manual Date: 01-04-2007 Version: 04
BREADSLICER 208	Page 11

7 PRODUCT DESCRIPTION

7.1 Purpose of the machine

The machine is meant to slice bread.

All parts of the machine, which come in contact with the bread are approved for use in the foods industry.

7.2 Inadmissible use of the machine

The machine is only meant for activities such as described in chapter 7.1.

The machine can only be cleaned with cleaning products, which are approved for use in the foods industry. Never use corrosive products!

Be sure the machine is placed on a flat floor.

The machine can only be used when the infeed cover and crumb tray are placed.

Never put your hands into the cover and knives when using the machine (see figure 3.3).

Only use original spare parts.

Do not use bread or other products with metals, stones or other peculiar objects inside.

Daub Bakery Machinery B.V.	Manual Date: 01-04-2007 Version: 04
BREADSLICER 208	Page 12

7.3 Description of the control panel

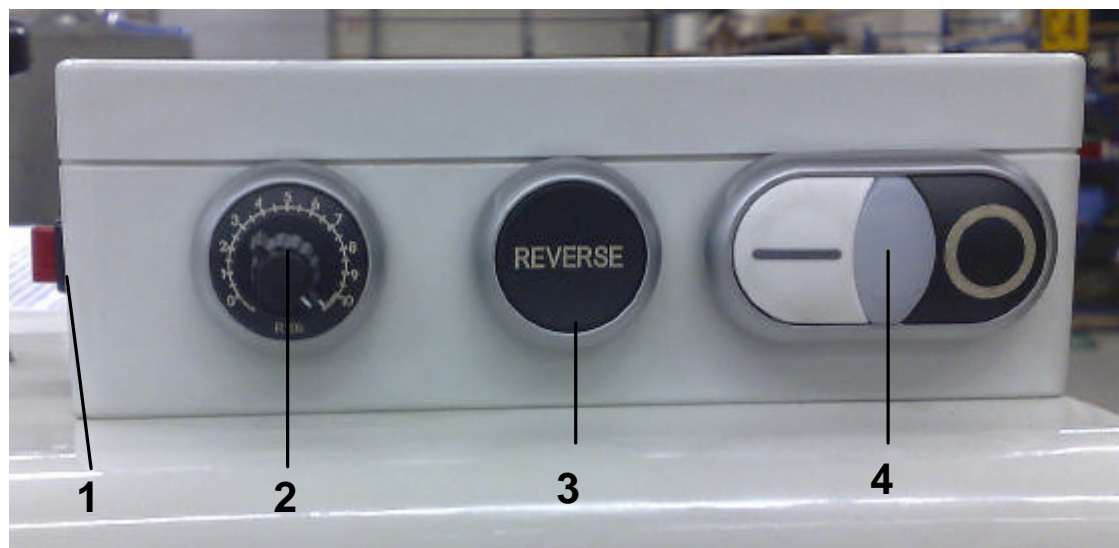

Figure 7-2

Position	Description
1.	On/off button bagblowing device
2.	Speed control of infeedbelt
3.	Reverse button of infeed belt for taking out last breads
4.	Start / Stop button of the machine

7.4 Working of the control panel

See figure 7-2 page 13

Position 1; On/off button bagblowing device

With the button the ventilator can start or shut off. When starting the ventilator will blow the plastic bags open to push the sliced bread into the bag

Position 2; Speed control infeed belt

By rotating this knob the speed of the infeed belt can be regulated. Depending on the hardness of the bread the right speed must be selected.

Position 3; reverse button

The last breads can not be sliced. To take these breads away push the reverse button; the belt will move reversly.

Position 4; Start/stop button

Pressing the "I" the machine will start. By pressing the "O" the machine will stop

Daub Bakery Machinery B.V.	Manual Date: 01-04-2007 Version: 04
BREADSLICER 208	Page 13

7.5 Taking in use of the machine

Check if the machine is placed correctly as described in chapter 5 “Installation”.

Check if it is necessary to clean the machine because of possible transport dirt.

Also check if the voltage on the machine plate is in accordance with that of your main supply.



Be sure the machine is place on a solid and flat floor.

Turn the main power to the machine by rotating the main switch to “I”

You can now proceed with the first test!

BE AWARE: after a couple of hours of use it is advisable the check the following items:

1. Tension of the knives as the complete construction may have set it self which can cause a loss of tension.
 - The tension of the knives is important for the results of the right thickness of the sliced product
2. The position of the infeed belts; it is possible that the position of the belts are not in the middle anymore thus moved to a side. See chapter 9.2 maintenance -> infeed belt for more instructions

Daub Bakery Machinery B.V.	Manual Date: 01-04-2007 Version: 04
BREADSLICER 208	Page 14

8 WORKING WITH THE MACHINE



Qualified employees older than 16 years may only operate the divider rounder.

1. Set the correct height of the infeed with the swivel (see figure 3.3) so the bread is pushed a little bit in, but enough the belts will move the bread through the knives.



Adjust the height of the infeed belt only when the machine is running

2. Regulate the speed of the infeed belt to the type of bread by using knob 2, figure 7.2
 - a. Warm bread and hard crusted bread on a lower speed



If the result is not correct please check the tension of the knives or new knives should be placed

3. On the frame of the infeed belt and the wrapping tray you will find bread guides. Those bread guides can be adjusted easily to the length of the loaves.

Daub Bakery Machinery B.V.	Manual Date: 01-04-2007 Version: 04
BREADSLICER 208	Page 15

9 MAINTENANCE

9.1 Cleaning

The numbers in the text refer to those in figure 3.3 .



Always turn the main switch to "0" (=off) before starting any kind of maintenance.



Never clean the machine with water. The use of water will cause oxidation and electrical problems.



Only qualified employees may clean the machine.



Other persons should keep some distance.

Daily:

- Clean the crumb tray and the belts
- Clean the knives specially by using some oil to week the bread to remove more easily

Weekly

- Clean lower shaft and yellow belts and the space between the yellow belts (BA-15) and the swivels (BA-08)

9.2 Maintenance

Periodically

- Every 400 hours grease bearings (BA-11). These bearings can be found by removing the crumb tray, where the lower shaft is places. Each side you find to grease nipples (BA-12)
- Check the tension of the V-belt (BD-04)
- Grease and check the tension of the chains
- If oil lubrication is used check the condition of the felt (see more information at chapter 10)
- Infeed belt

The belt is tensioned in the factory and set in such a way that running over the red lines is being avoided. If the belt does run over these lines do the following:

If the belt runs over the right, the right suspension bolt of the shaft driving roller (BH-25) should be turned a quarter to the right. Let the belt run approximately 1 minute and check again. Repeat the procedure until the belts runs straight.

Follow the same steps if the belt runs over to the left. Only now the left suspension bolt should be turned a quarter to the right.

If the belt slips both suspensions bolts need to be turned



Check the chains between motor redactor and the infeed belt. It can be retightened by damper BH-10

Daub Bakery Machinery B.V.	Manual Date: 01-04-2007 Version: 04
BREADSLICER 208	Page 16

9.3 Instructions changing infeed belt

1. Remove the complete plug of the infeed bet, which is situated under the infeed belt next to the switchbox
2. Remove the complete upper infeed belt construction (BJ)
3. Remove the guides (BH-19)
4. Remove the 4 bolts of the tubular rivets (BH-18). The table is loose now.



BE AWARE: Table is big and heavy
The table must be supported (by a second person)

5. Put the infeed table upside down on a working table
6. Loose damper (BH-10)
7. Remove cover (BH-07)
8. Remove the chain of the reductor
9. Loosen the bolts BH-25 and remove
10. Remove driving roller (BH-25) with chain
11. Remove roller BH-24
12. Remove the top of the infeed belt BH-07 with motor and reductor BH40+41
13. Remove infeed belt BH-20

9.4 Instructions changing knives



The knife should be positioned and tensioned correctly for the best slicing results
This should be done by a technician
Please read procedure carefully



Turn off the main switch of the machine

RECOMMENDABLE: Renew the yellow belts as well when changing the knives to have the best slicing result

Before changing the knives do the following to get an impression of the right tension of the knives; Press two knives to each other with thumb and forefinger. The tension you feel should be at least the tension to the new knives.

1. remove the cover BL-01+02 and BK-07 at the top of the bach side of the machine
2. Remove upper pressure plate BJ-14 complete with support BJ-16
3. By removing the 4 bolts at the side of the frame (BK-10) and loosen the 2 bolts at the inner side at the bottom of the out feed table you can tilt down the front table and lift it out of the hooks. This is to be needed to have a good working space
4. Turn the 2 bolts which are behind the round plates (BK-08) 2 or 3 turns loose.

Daub Bakery Machinery B.V.	Manual Date: 01-04-2007 Version: 04
BREADSLICER 208	Page 17

5. Turn the bolts at the the top of the machine by one turn each. The upper shaft BA-03 will come down horizontally. After 14 turns of eah bolt the blades can be taken out of the knife holder (BA-06)
6. While removing the knives do not try to move the top swivels BA-05.
First check how the knives are placed. Remove the knives which should be replaced and place the new knives.
In case you remove all the knives place first 2 knives most left and right to form a crossing frame (see picture 7.1)

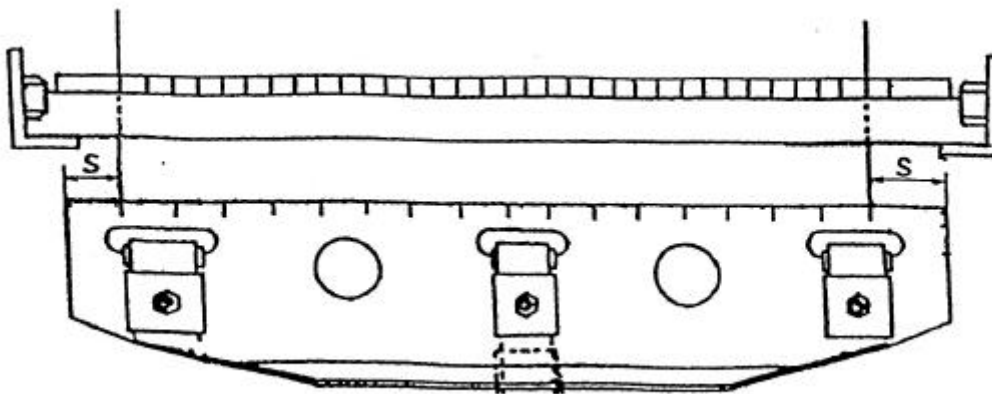

Figuur 7.1



There is more distance S at the right side than at the left side. The knife at the right is placed one groove further in the knife board.

Now the knives can be placed one to each groove in the white knife guide boards and each to a cross set of knife holders. The knives must be as close as possible positioned to the long side of the knife holder (see detail in figure 7.2)

7. The knife holder should be free of the yellow belts after putting tension to the knives. If not the belts will be damaged. Place before tensioning the belts a small piece of plastic about 1 cm thick between the belts and the knife holder (see figure 7.2)
8. Now put the tension to the knives by turning the bolts on top of the frame stroke by stroke. Afre 14 strokes you are back to the original position (see 5.). Check the tension to the knives with your fingers.
9. Check if the yellow belts are in the middle of the upper and lower swivels (BA-05 and BA-08).

Daub Bakery Machinery B.V.	Manual Date: 01-04-2007 Version: 04
BREADSLICER 208	Page 18

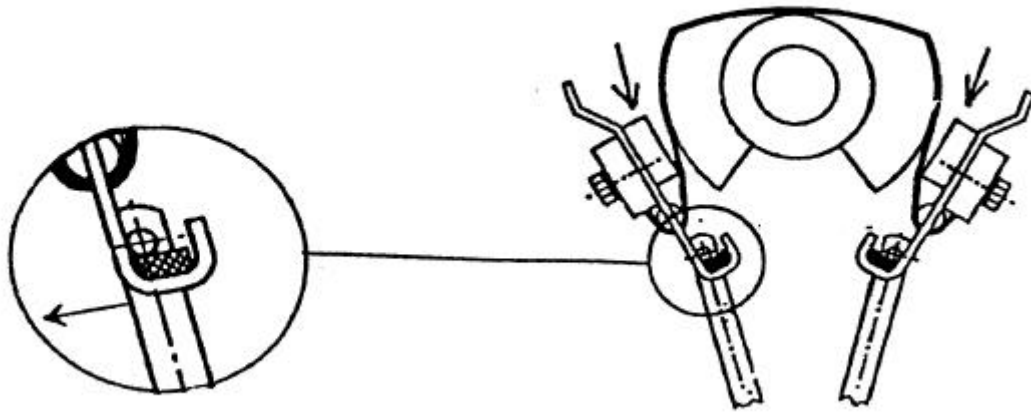

Figuur 7.2

Before putting the definitive tension to the knives check the distance between the knives. The distance should be equal. If not move the two knife holder more to the correct position.

10. Now the tension can be pressed up

11. Remove the plastic pieces. Tighten the knives to its desired tension.

12. Check the distance of the yellow belts in the knife holder. Move the aluminium belt guides with a screw driver into the opening (see figure 7.3)

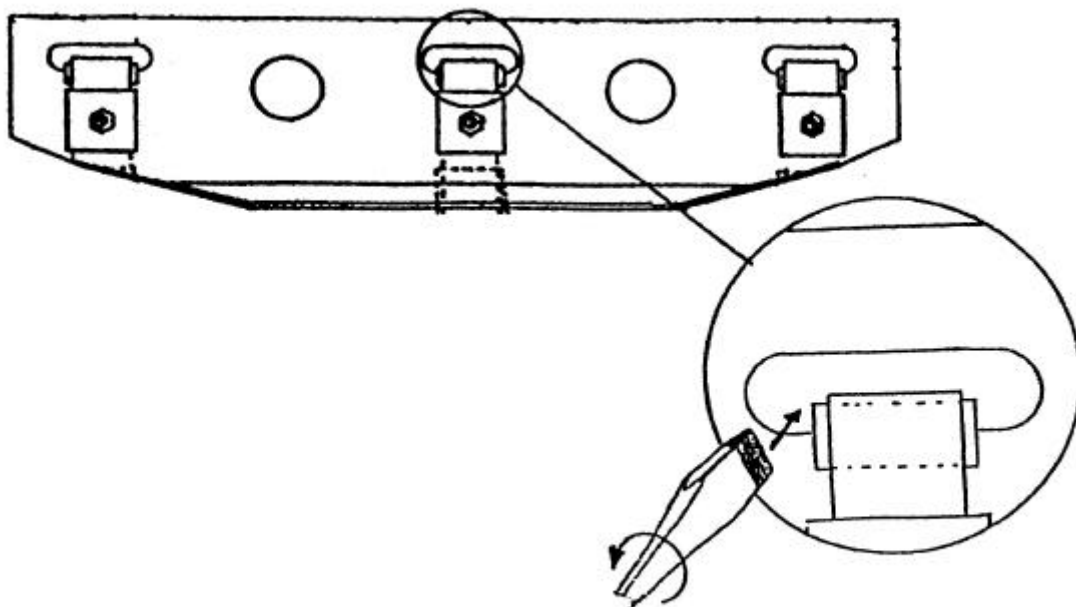

Figure 7.3

Daub Bakery Machinery B.V.	Manual Date: 01-04-2007 Version: 04
BREADSLICER 208	Page 19

Correct tension of the knives.

1. In case the tension of the knives are not sufficient the slices will be curved.
2. In case the knives are tensioned too much you will hear a knocking sound.

10 OILLUBRICATION OF THE KNIVES (OPTIONAL)

By use of a breadslicer with oil lubrication the knives will be greased through the upper knife guide (BJ-14) in which a piece of felt will be sprayed with oil. Due the capillary action of the felt, the felt will saturate completely with oil. As the knives slides along the felt the knives will be greased.

Depending on the type of bread the felt must be cleaned or replaced regularly. We advise to do it monthly.

The pollution of the felt is less with cooled down bread.

10.1 Adjustment of the oil quantity

The supply of oil can be arranged by a timer in the switch box (BZ-21). The timing relay has a "T-on" and a "T-off" turning knob. By turning the "**T-off**"-knob the requested oil quantity can be set. The pause time will change, as well the oil quantity in time.

Do not use the "T-on"-knob as this one is regulating the running of the oil pump.

The yellow push button at the side of the switch box makes it possible to turn the oil pump on or off. We advise not to use the machine too long without oil because the felt will dry up and lose its working. Furthermore the knives will lose its lubrication and may become in contact with the steel of the upper knife guide. A metallic contact appears which leads to a quicker wear of the knives.

If the oil reservoir is almost empty the red warning light in the switch box will light up.

Fill the reservoir with an oil which may be used in the food environment, but as well harsh / resin free to avoid the oil to get hard in time, which will harm the working of the pump, tubes and the felt.

Daub Bakery Machinery B.V.	Manual Date: 01-04-2007 Version: 04
BREADSLICER 208	Page 20

11 FAULT FINDING

The following faultfindings could appear in the display of the freq.controller

- E01 Overcurrent
Check if the motor is overloaded
 - Transport belts are too tight
 - Chains are too tight
- E05 Overload
Check if the motor is overloaded
 - Transport belts are too tight tensioned or rubbing
 - Chains are too tight or blocked
- E07 Overvoltage
Check if the power supply to the freq.controller is between 220 V and 240 Volt
Check the connection of the neutral (blue wire) at the power supply
- E09 Undervoltage
Check power supply
- E14 Ground fault
Check earth/ground connection or short circuit
- E21 Temperature too high
Check the temperature of the surroundings is lower then 40 degrees as well in the switch box itself

More information regarding the freq.controller can be found on the CD supplied in the switchbox.

12 FIGURES AND DIAGRAMS

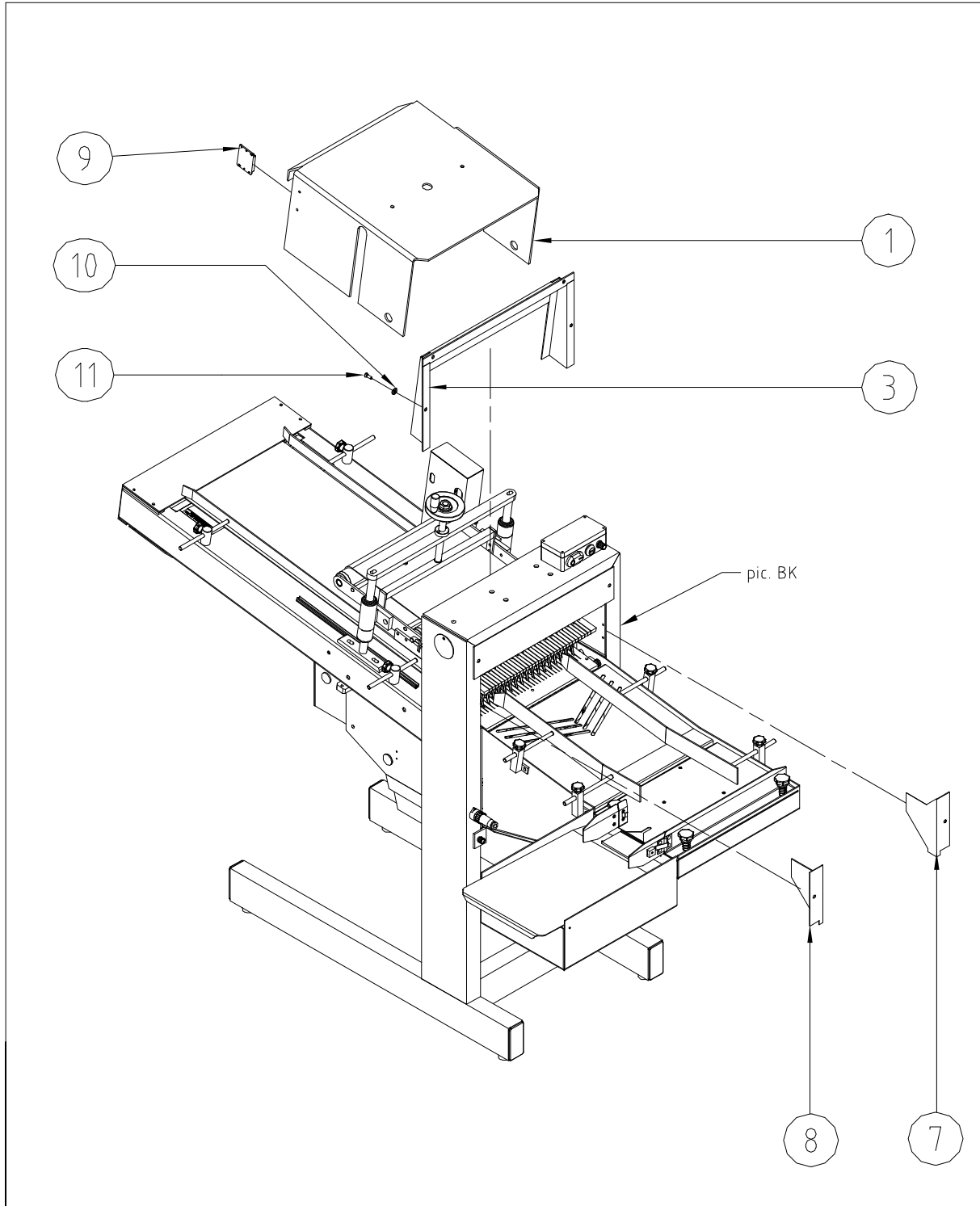

Name: BREADSLICER 208-2000/bagblower	Weight:	Art. Code:
	Picture: BI	File: MT-B8-40-CPL-03.3

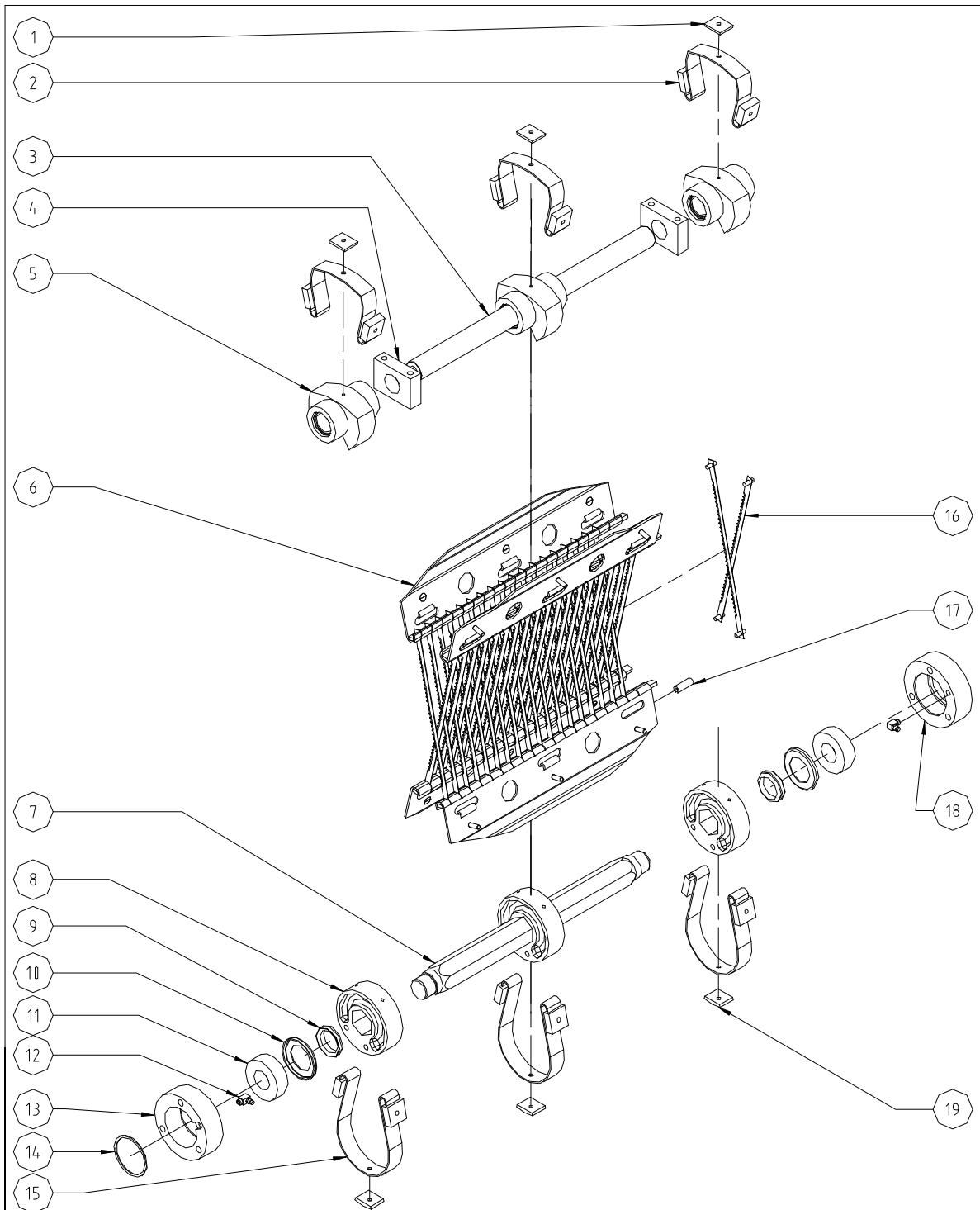

Name:

SET OF KNIVES

Weight:

Art. Code:



Picture:

BA

File:

MT-BX-40-MES-00.0

Daub Bakery Machinery B.V.	Manual Date: 01-04-2007 Version: 04
BREADSLICER 208	Page 23

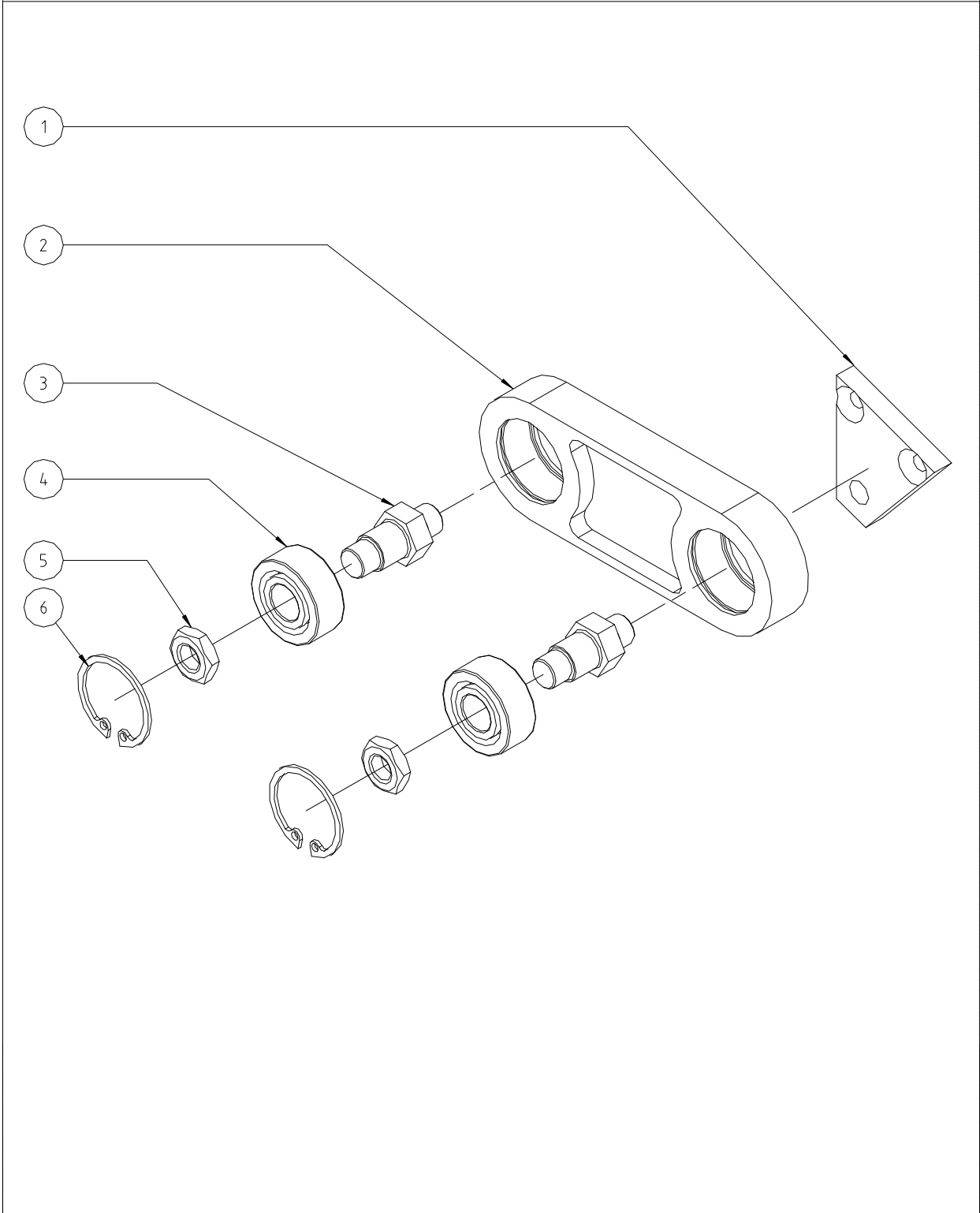

Name: CONNECTING-ROD COMPLETE	Weight:	Art. Code: 90-BR-00846
	Picture: BC	File: MT-BX-XX-AAN-01.0

Daub Bakery Machinery B.V.	Manual Date: 01-04-2007 Version: 04
BREADSLICER 208	Page 24

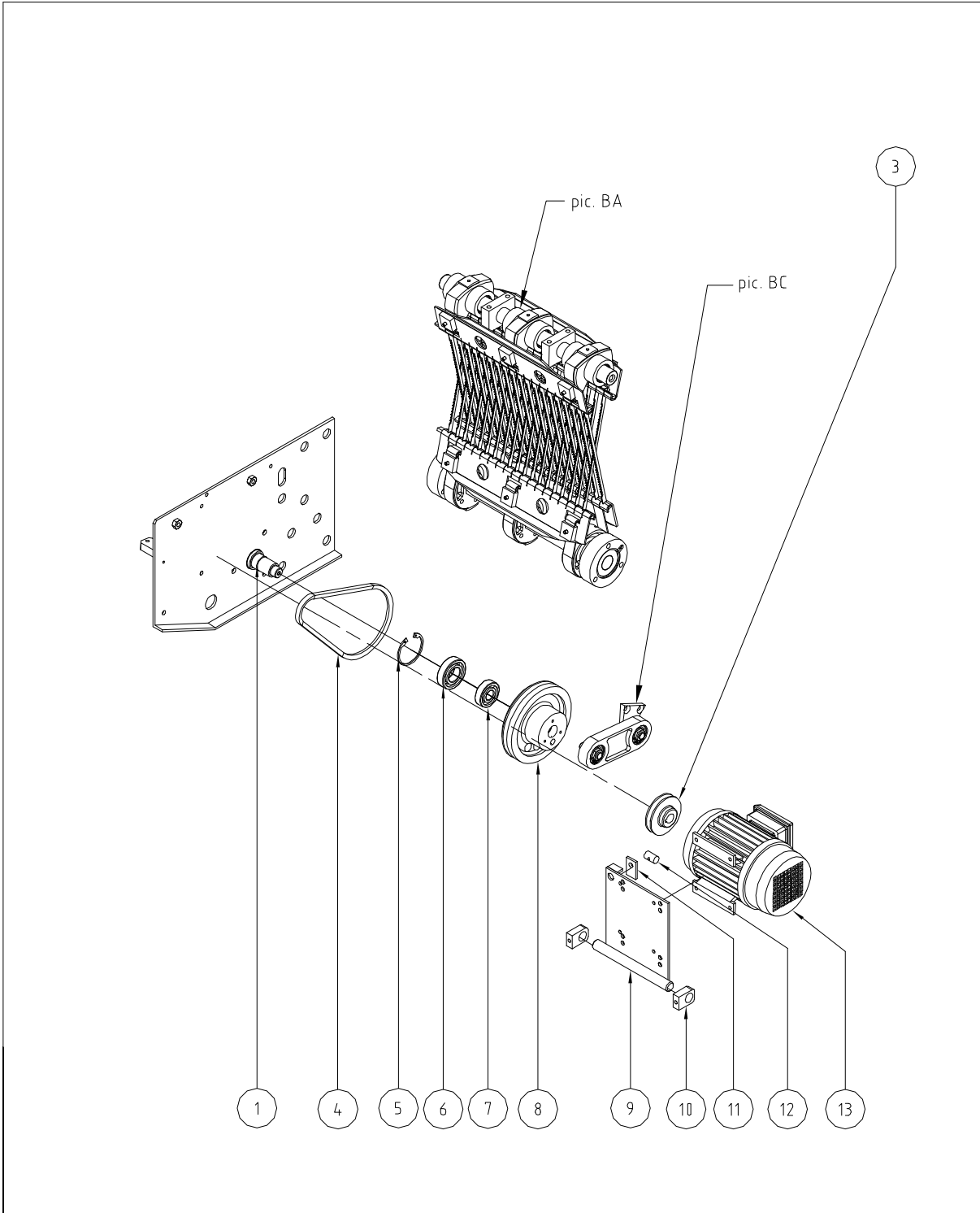

Name: DRIVE OF KNIVES	Weight:	Art. Code:
	Picture: BD	File: MT-BX-XX-AAN-00.1

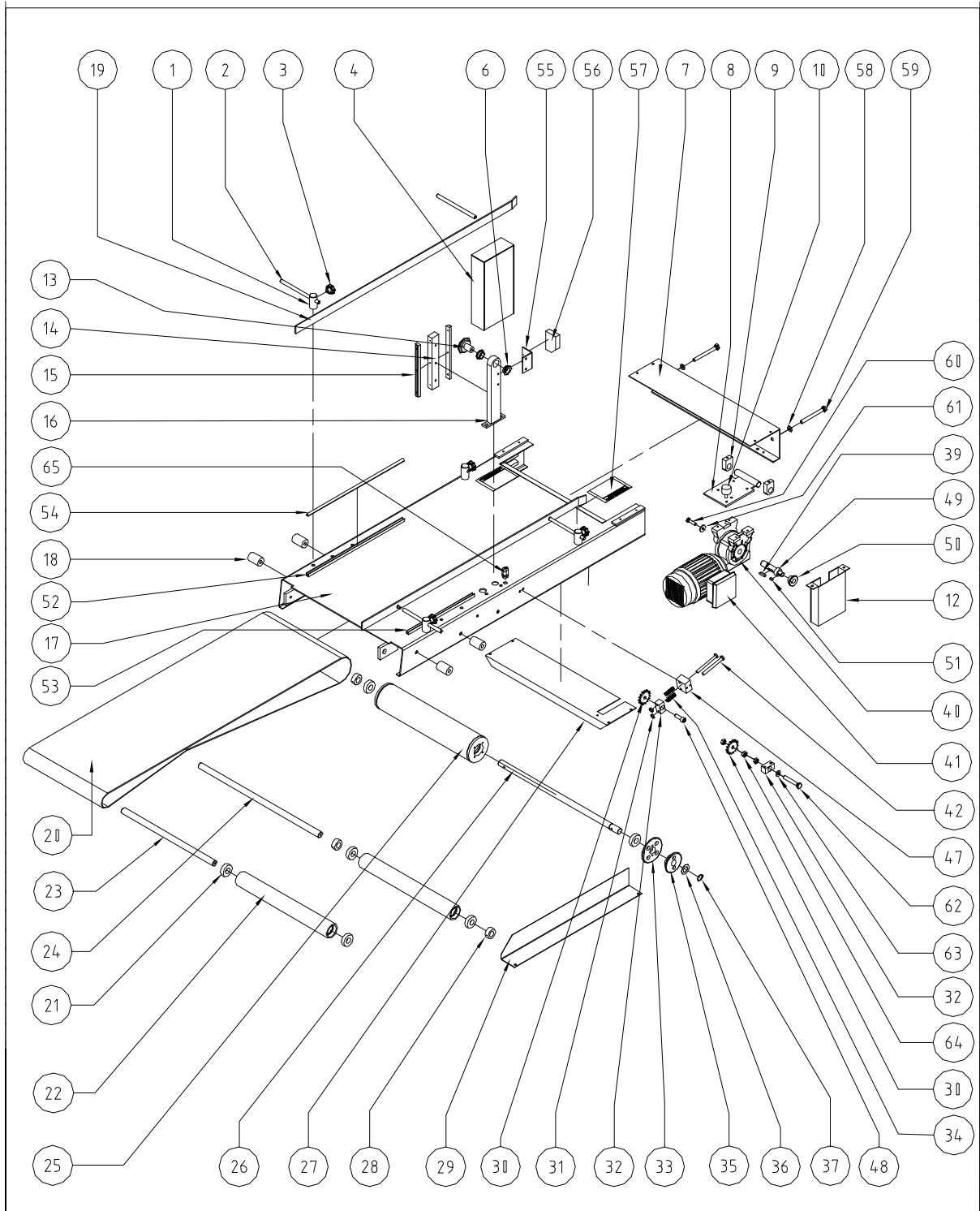

Name:
INFEED WITH BELT

Weight:

Art. Code:



Picture:

BH

File:

MT-B8-40-INV-00.2

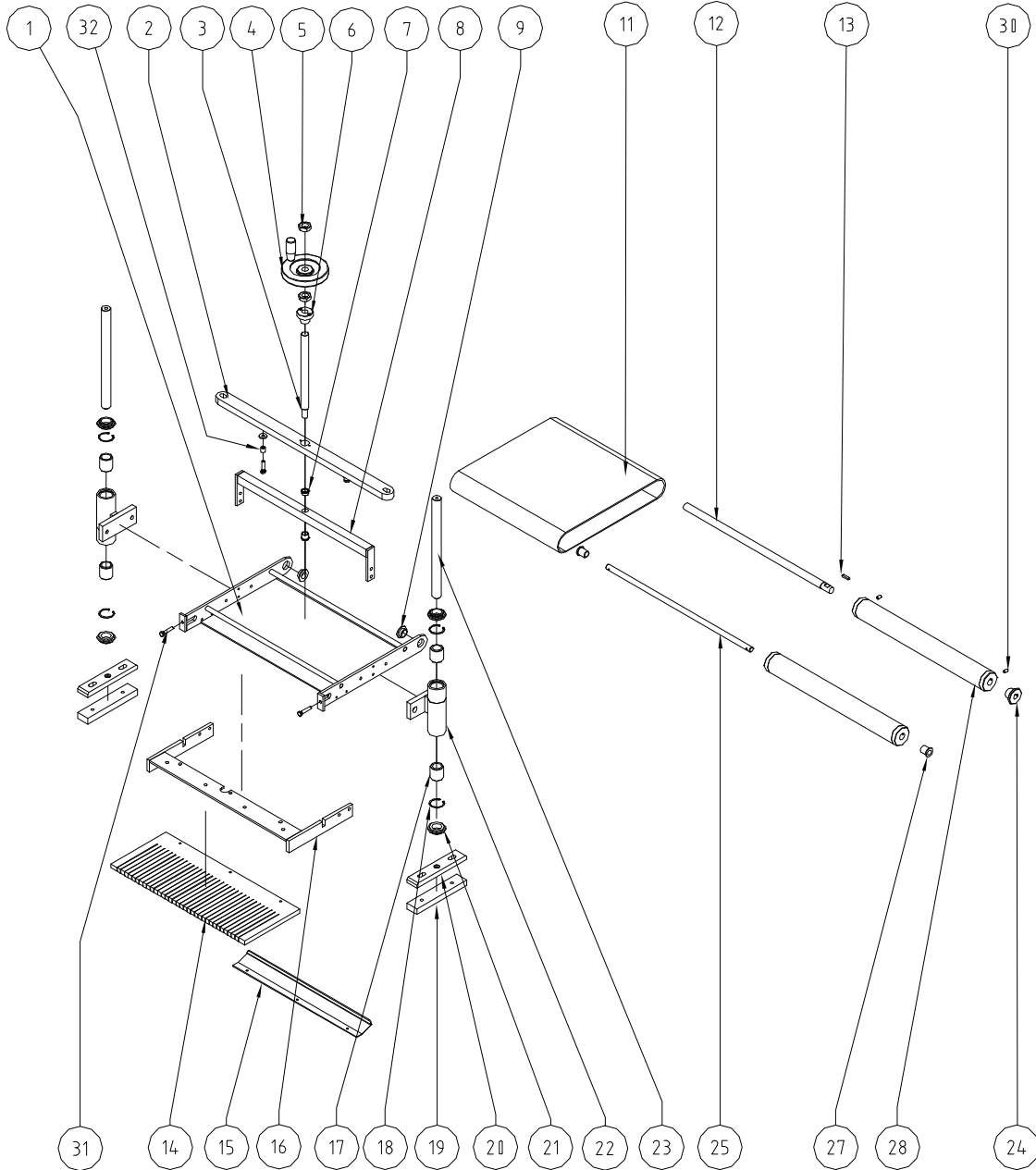

Name:
UPPER INFEED BELT

Weight:

Art. Code:



Picture:
BJ

File:
MT-B8-40-INV-10.2

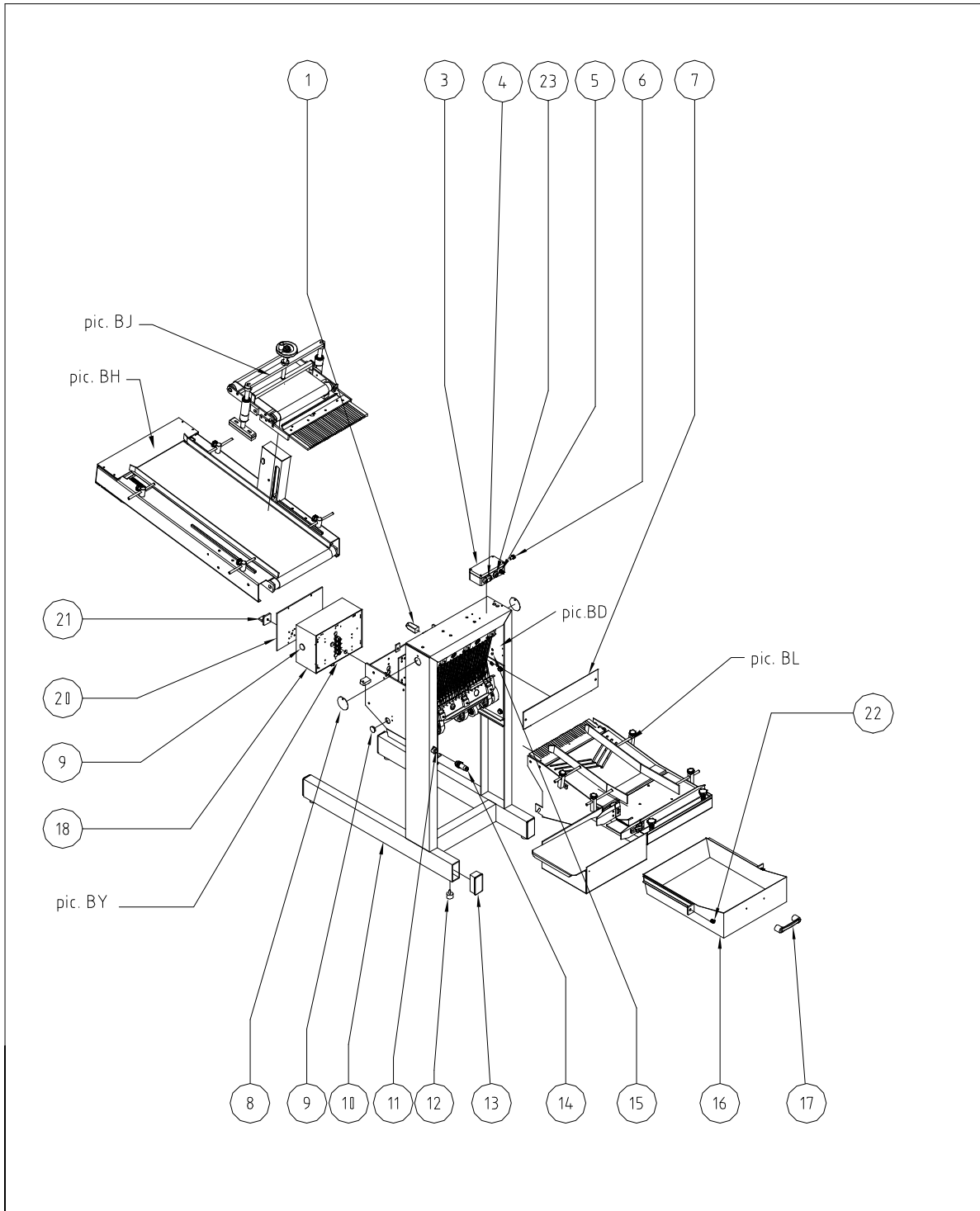

Name:
BREADSLICER WITH BAGBLOWER

Weight:

Art. Code:



Picture:

BK

File:

MT-B8-40-CPL-02.2

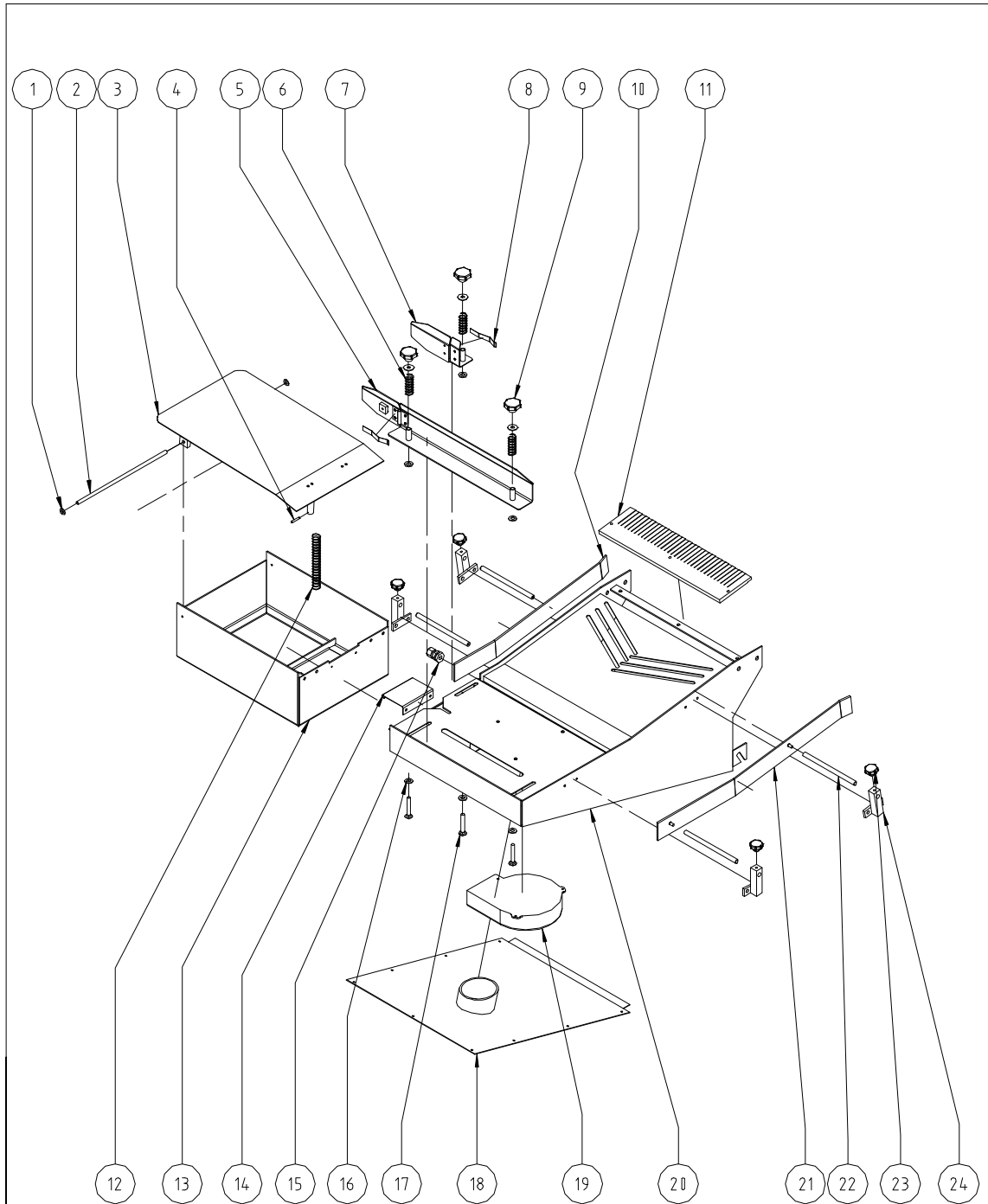

Name:
OUTFEET WITH BAGBLOWER

Weight:

Art. Code:



Picture:

File:

BL

MT-B8-40-OUT-01.0

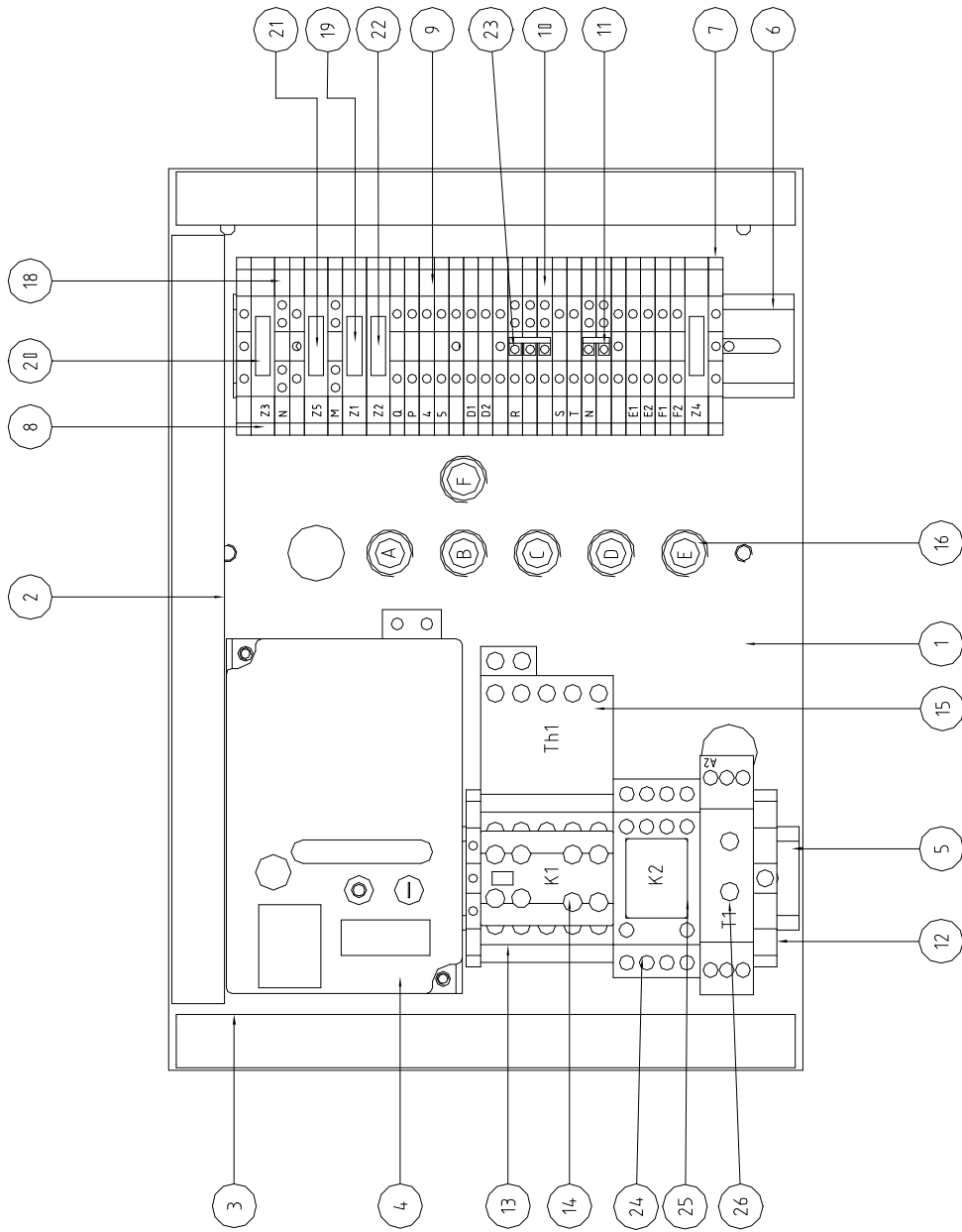

- A: Belt-motor
- B: Panel
- C: Potentiometer
- D: Knife-motor
- E: Oillubrication
- F: Bagblowingdevice (option)

Picture: BZ File: BRE-208-11-112

Name: Switchbox breadslicer 208 oil



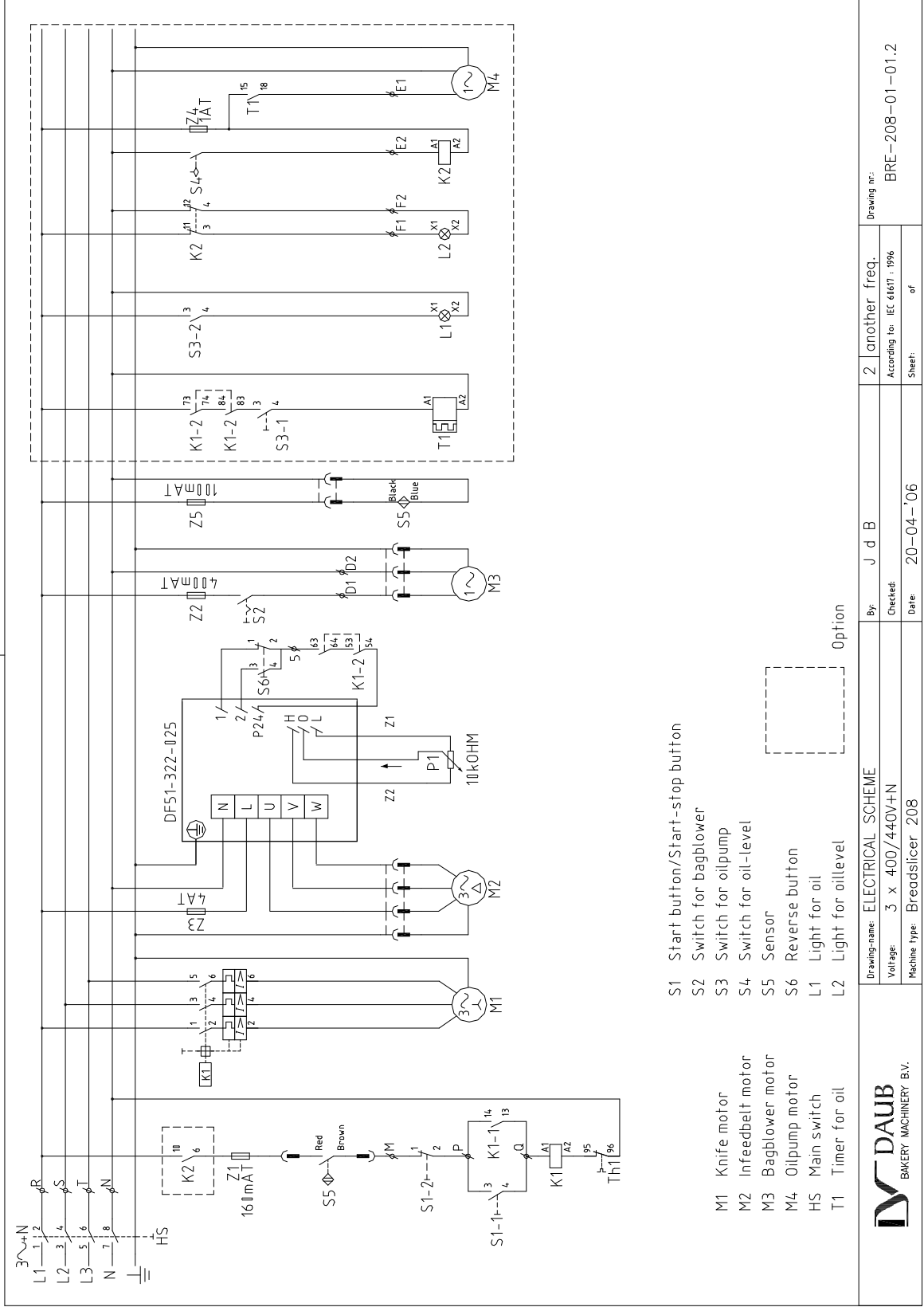

- S1 Start button/Start-stop button
- S2 Switch for bagblower
- S3 Switch for oilpump
- S4 Switch for oil-level
- S5 Sensor
- S6 Reverse button
- L1 Light for oil
- L2 Light for oillevel
- M1 Knife motor
- M2 Infeedbelt motor
- M3 Bagblower motor
- M4 Oilpump motor
- HS Main switch
- T1 Timer for oil

Drawing-name: ELECTRICAL SCHEME		By: J d B	2	another freq.
Voltage: 3 x 400/440V+N		Checked:	According to: IEC 61671 - 1996	
Machine type: Bread slicer 208		Date: 20-04-'06	Sheet: of	
Drawing nr.: BRE-208-01-01.2				



Daub Bakery Machinery B.V.	Manual Date: 01-04-2007 Version: 04
BREADSLICER 208	Page 31

13 PART LIST

Pos.no.	Article code	Description	Qty	Recommended
BA-01	00810	Clip piece of upperbelt	3	
BA-01	00810	Clip piece of upperbelt	4	
BA-02	00809	Upperbelt	3	*)
BA-03	00879-1	Top shaft -40-	1	
BA-03	01259	Top shaft -52-	1	
BA-04	01267	Support block upper shaft	2	
BA-05	90-BR-00808	Top swivel complete	3	
BA-05	90-BR-00808	Top swivel complete	3	*)
BA-05	90-BR-00808	Top swivel complete	4	
BA-06	11005-40-10	Knifeholder 40-10	4	
BA-07	02872-40	Under Shaft -40- hexagon	1	
BA-08	02922	Lower swivel plastic with hexagonal aperture	3	*)
BA-08	02922-ALU	Lower swivel aluminium	3	
BA-08	02922-ALU	Lower swivel aluminium	4	
BA-09	61247	Butterfly ring V35	2	
BA-10	60865	Bearing sealing segment Z007 (*)	2	
BA-11	61246	Swivel joint roll.bearing 22206.ES.TVPB (*)	2	
BA-12	60869	Grease nipple H3 8mm	2	
BA-13	00884	Bearing house lower shaft (left)	1	
BA-14	60863	Retaining ring BR60 (*)	1	
BA-15	00815	Lowerbelt	3	*)
BA-16	00832	Blade L=257 1/4" steel	38	*)
BA-17	00811	Belt guide	6	
BA-17	00811	Belt guide	12	
BA-18	00814	Bearing house lower shaft (right)	1	
BA-19	00816	Clip piece of lowerbelt	3	
BA-19	00816	Clip piece of lowerbelt	4	
BA11	61246	Swivel joint roll.bearing 22206.ES.TVPB (*)	2	
BA14	60863	Retaining ring BR60 (*)	1	
BB-01	61251	Slide bearing 08-10-10	2	
BB-02	01295-40	Lever knifeguide -40-	1	
BB-03	61213	Torsion spring right	1	*)
BB-04	61212	Torsion spring left	1	*)
BB-05	61018	Ball knob 25*M6	1	
BB-07	11002-40-10	Knifeguide upper 40-10	1	
BB-08	01371-40	Input guide strip -40-	1	
BC-01	00823	Lever connecting rod	1	
BC-02	00822-1	Connecting rod	1	
BC-03	00821-1	Bearing tap connecting rod	2	
BC-04	62061	Ball-bearing self-aligning (*)	2	
BC-05	60886	Screw nut M14*1.25	2	
BC-06	61436	Retaining ring J40	2	
BD-03	00824	V-belt pulley motor SPZ80	1	
BD-03	01312	Pulley motor SPZ71	1	
BD-04	60921	V-belt SPZ 737 LW	1	
BD-04	60921	V-belt SPZ 737 LW	1	*)
BD-05	60264	Retaining ring J62	1	

Daub Bakery Machinery B.V.	Manual Date: 01-04-2007 Version: 04
BREADSLICER 208	Page 32

BD-06	60876	Ball bearing 6206Z SKF	1
BD-07	60875	Ball bearing 6304Z (*)	1
BD-08	00819	Pulley	1
BD-09	00742	Motor bracket cpl.	1
BD-10	00745	Motorsupport	2
BD-12	00746	Tension shaft motor bracket	1
BD-13	61341	Motor 0,55 kW RPM=1400	1
BH-01	01197	Support for guide belt side	4
BH-02	01196	Stift for guiding belt side	4
BH-03	60365	Star knob	4
BH-04	02142	Chain casing topbelt	1
BH-06	02144	Slide bearing for chain support	2
BH-07	01188-40	Nut piece conveyer 208 -40-	1
BH-08	01208	Motor support conveyer driving	1
BH-09	00745	Motorsupport	2
BH-10	60892	Rubber damper 30*20*M8	1
BH-12	02748	Safety cap chain	1
BH-13	02126	Chainwheel for topbelt	1
BH-14	02128	Chain guide strip	1
BH-15	02129	Guide for chain topbelt	2
BH-16	02127	Chain support for topbelt	1
BH-17	02121-40	Beltguide 208-40	1
BH-17	02121-52	Belt guide 208-52	1
BH-18	01207	Fixing bush	4
BH-19	01194	Guide for bread at belt side	2
BH-20	61120	Belt L=2300 W=350 (*)	1
BH-20	61435	Belt L=2300 W=470	1
BH-21	60405	Ball bearing 6004 2 ZR (*)	6
BH-22	01395-40	Auxiliary roller	2
BH-22	01395-52	Reverse roller 208/52	2
BH-23	01394-40	Shaft	1
BH-24	01191-40	Shaft	1
BH-25	01192-40	Driving roller complete -40-	1
BH-26	01190-40	Tension shaft driving roller 208/40	1
BH-26	01190-52	Clamping axle driving roller RBS 208/52	1
BH-27	01398-40	Cover plate driving roller	1
BH-27	01398-52	Cover plate driving roller	1
BH-28	00458	Collar sheel axle	3
BH-29	02143	Cover plate transport belt lower side	1
BH-30	61717	Chain wheel N3 3/8"-10 S (*)	1
BH-31	60218	Bolt ZK low M8 D439B	2
BH-32	02973	Block loose chain stretcher	1
BH-33	01399	Chainwheel drive roller 208	1
BH-34	60080	Compression spring	2
BH-35	02125	Chainwheel for driving lower belt	1
BH-36	01393	Slide ring for driving roller BRS-208	1
BH-37	60410	Retaining ring A20	1
BH-39	60179	Sunk key 6*6*25 D6885A	1
BH-40	62437	Reductor type GMR040/60	1
BH-41	61183	Motor T63B/4 0,18 kW	1
BH-43	02123	Filling block for chain tensioner	1
BH-45	61385	Flanged bush C12/15-12 / 1.5	1
BH-47	02123	Filling block for chain tensioner	1

Daub Bakery Machinery B.V.	Manual Date: 01-04-2007 Version: 04
BREADSLICER 208	Page 33

BH-49	01209-1	Motor axle 208-18mm	1
BH-50	01628	Chainwheel drive shaft	1
BH-51	61328	Sunk key 5*5*12	1
BH-54	61479	Draught strip	1
BH-56	62079	Photoelectric sensor	1
BH-58	60158	Locking ring M10 D125	2
BH-61	60732	Ring M8x25x1.5	1
BH-63	60158	Locking ring M10 D125	1
BH-64	60045	Nut M10	3
BH-65	62188-M12	Cable turnbuckle M12	1
BI-01	02737-40	Safety cap 1 upper conveyer -40-	1
BI-03	02736-40	Cover cap upper conveyer -40-	1
BI-07	02876-R-V	Pointer cap output right raise	1
BI-08	02876-L-V	Pointer cap output left raise	1
BI-10	61091-1	Panelled open ring M6 rvs	2
BI-10	61091-1	Panelled open ring M6 rvs	3
BI-11	60803	Screw	2
BI-11	60803	Screw	3
BJ-01	02136-40	Frame topbelt 208-40	1
BJ-01	02136-52	Frame topbelt 208-52	1
BJ-02	02796-40	Connection strip -40-	1
BJ-02	90049-40	Bracket cpl -40-	1
BJ-02	90049-52	Bracket CPL -52-	1
BJ-03	02133	Adjusting stud	1
BJ-04	02134	Handwheel adjusting bow	1
BJ-05	60165	Nut ZK low RVS M16 D439B	2
BJ-06	02795	Bush with thread	1
BJ-06	02795	Bush with thread	1
BJ-07	01642	Slide bearing C12/15	0
BJ-07	01642	Slide bearing C12/15	1
BJ-07	61385	Flanged bush C12/15-12 / 1.5	1
BJ-08	02132	Adjusting bow -40-	1
BJ-08	02153	Adjusting clamb -52-	1
BJ-09	02767	Slide bearing	2
BJ-11	61651	Belt L=715, W=320 (*)	1
BJ-11	61678	Belt FAS-8E L=715 W=440 (*)	1
BJ-12	02140-40	Drive shaft upperbelt	1
BJ-12	02140-52	Driving shaft topbelt 52	1
BJ-13	61327	Sunk key	1
BJ-14	11002-40-10	Knifeguide upper 40-10	1
BJ-15	01371-40	Input guide strip -40-	1
BJ-16	02959-40	Holder for knife guide upper	1
BJ-17	61512	Bush bearing 20*32*42,2RS (*)	4
BJ-18	61770	Retaining ring 32 mm D472	2
BJ-18	61770	Retaining ring 32 mm D472	4
BJ-19	02294	Locking plate	2
BJ-20	10209	Fixing plate for guide suppoart	1
BJ-21	02395	Filling disc for guide bush	2
BJ-21	02395	Filling disc for guide bush	4
BJ-22	02135	Guide bush	2
BJ-23	10210	Linear shaft	1
BJ-23	10210	Linear shaft	2
BJ-24	01628	Chainwheel drive shaft	1

Daub Bakery Machinery B.V.	Manual Date: 01-04-2007 Version: 04
BREADSLICER 208	Page 34

BJ-25	02141-40	Tensioning shaft upperbelt	1
BJ-27	61648	Slide bearing NR0081299 nylon 6.6	2
BJ-28	90-BR-02137-40	Roller topbelt -40- complete	2
BJ-28	90-BR-02137-52	Roller topbelt -52-	2
BJ-30	60062	Adjusting screw MBZ M6*10	2
BJ-32	01415	Bush locking HV	1
BJ-32	01415	Bush locking HV	2
BJ-32	60254	Hex head screw M6 x 25	1
BJ-32	61099	Ring	2
BK-01	62245-A	Connector house	1
BK-01	62245-B	Connector house construction	1
BK-01	62245-C	Connector connection male	1
BK-01	62245-D	Connector connection female	1
BK-03	61043	Switchbox	1
BK-04	62100-01	Contact element 1*make	2
BK-04	62101-01	Contact element 1*breaker	2
BK-04	62102-01	Attachment adapter contacts	2
BK-04	62207-01	Dubble push button wit/black	1
BK-05	62433	Potential meter	1
BK-06	61476	Switch 03-49-902RD (*)	1
BK-07	02875-40	Upper part for safety guard -40-	1
BK-08	00828	Cover plate portal	2
BK-09	62223	Blind plate grey	1
BK-09	62223	Blind plate grey	2
BK-09	62242	Plug natural hole round 30	2
BK-10	02892-40	Frame 208 -40- raise	1
BK-11	61258	Connector 692 male 05.68.1204 (*)	1
BK-11	61258	Connector 692 male 05.68.1204 (*)	2
BK-12	60953	Rubber buffer	4
BK-13	60919	Insert cap 100*50	4
BK-14	61538	Connector 692 FEM. 05.68.1304 (*)	1
BK-14	61538	Connector 692 FEM. 05.68.1304 (*)	2
BK-15	61581	Sealing plug natural	6
BK-16	01339-40	Crumb drawer	1
BK-17	62010	Handle	1
BK-18	02584	Switchbox	1
BK-19	62223	Blind plate grey	1
BK-20	02583	Lid switchbox	1
BK-21	60049	Main switch M220 61194-003M1	1
BK-22	60365	Star knob	2
BK-23	62122	Push button	1
BK-23	62126	Indicationplate "reserve"	1
BL-01	61111	Closing ring M4 SS	2
BL-02	01051	Shaft hinge pressure plate bag blower	1
BL-03	01047-52	Pressure plate bin bag blower -52	1
BL-04	61025	Stretching pin 4*25 D1481	1
BL-05	01807-40	Conduction for left complete bagblower -40-	1
BL-05	01807-52	Guide front left	1
BL-06	61437	Compression spring ZOB	3
BL-07	01808	Guide rear left	1
BL-08	01800	Spring bread conduction bag blower	2

Daub Bakery Machinery B.V.	Manual Date: 01-04-2007 Version: 04
BREADSLICER 208	Page 35

BL-09	60077	Star-shaped knob black S-40 M8	3
		Side guide short bagblower left	
BL-10	01802-L		1
BL-11	11001-40-10	Knifeguide lower 40-10	1
BL-12	60924	Spring	1
BL-13	01042-40	Bin bagblower	1
BL-14	01060	Bag holder for bag blower	1
BL-15	62188-M12	Cable turnbuckle M12	1
BL-15	62188-M16	Cable turnbuckle M16	1
BL-16	60276	Nylon washer M10	6
BL-17	61438	Blocking bolt M8*55 DIN 603	3
BL-18	01215-40	Bottom plate (front table bagblower)	1
BL-18	01215-52	Bottom plate for a bagblower 208-52	1
BL-19	61026	Ventilator	1
BL-20	01213-40	Front table (bagblower)	1
BL-20	01213-52	Front table	1
		Side guide long bagblower left	
BL-21	01801-L		1
BL-22	01196	Stift for guiding belt side	4
BL-23	60365	Star knob	4
BL-24	01400	Support for side guide	4
BL-25	62188-M20	Turnbuckle M20	1
BZ-01	01402	Assembly plate 208	1
BZ-04	62191-1	Frequency control 0.25 KW	1
BZ-07	61175	Ground terminal WM WPE2.5 101000	7
BZ-08	61173	Fuseholder WM WSI6 101100	5
BZ-09	61174	Rail clamp WM WDU2.5 102000	12
BZ-09	61174	Rail clamp WM WDU2.5 102000	14
BZ-10	61656	Rail clamp WM WDU2.5ZR 102470	4
BZ-10	61656	Rail clamp WM WDU2.5ZR 102470	5
BZ-11	61657-1	Elec. interconnection WQV2.5/2	1
BZ-12	61171	End support VE 40001	1
BZ-13	62139	Relay switch 230V 50 Hz	1
BZ-14	62141	Extra switch bloc	1
BZ-15	61754	Thermal relay, 1-1, 6A	1
BZ-15	61894	Thermal relay ZE 2.4	1
BZ-15	61895	Thermal relay ZE 4	1
BZ-16	62188-M16	Cable turnbuckle M16	6
BZ-16	62188-M16	Cable turnbuckle M16	7
BZ-17	62235-M16	Blind plug	1
BZ-18	61658-1	Elec. interconnection WQV2.5/3	1
BZ-18	61658-1	Elec. interconnection WQV2.5/3	2
BZ-19	61655	Rail clamp WM WDU1.522	2
BZ-19	61655	Rail clamp WM WDU1.522	3
BZ-20	61283	Kuhnke relais 111-A-4 230VAC	1
			Ton 0,1 s / Toff
BZ-21	61660	Bifunctional timerelay	1 8 s
BZ-22	61284	Relay socket	1
BZ-23	61474	Fuse glass 160mAT	2
BZ-24	60469	Fuse 4AT 5*20	2
BZ-25	60617	Fuse 1AT 5*20	2
BZ-26	60468	Relay 400MAS 5*20	2