



K+ DR-800

Duck Oven

Standard Features:

- AISI 304 grade stainless steel construction throughout
- Flame failure as standard
- Lever action gas control
- Volcanic rock help distribute heat evenly
- Oil drain with valve
- Excess fat drain off provided by duck hanging rail
- Easily accessible duck hanging rail
- Overheat safety device
- Temperature display
- 18-month warranty

Specifications:

MODEL	DIAMETER (mm)	HEIGHT (mm)	GAS CONSUMPTION (MJ/h)	
			NG	LPG
DR-800	800	1500	73	54

Connections:

GAS (GI) (BSP)	WASTE (W) (BSP)	OVERFLOW	SUPPLY PRESSURE (kPa)	
			NG	LPG
3/4" (M)	2" (M)	1.5" diameter pipe	1.0	2.6

- Regulator is included in the unit
- **Must** be installed by an authorised installer

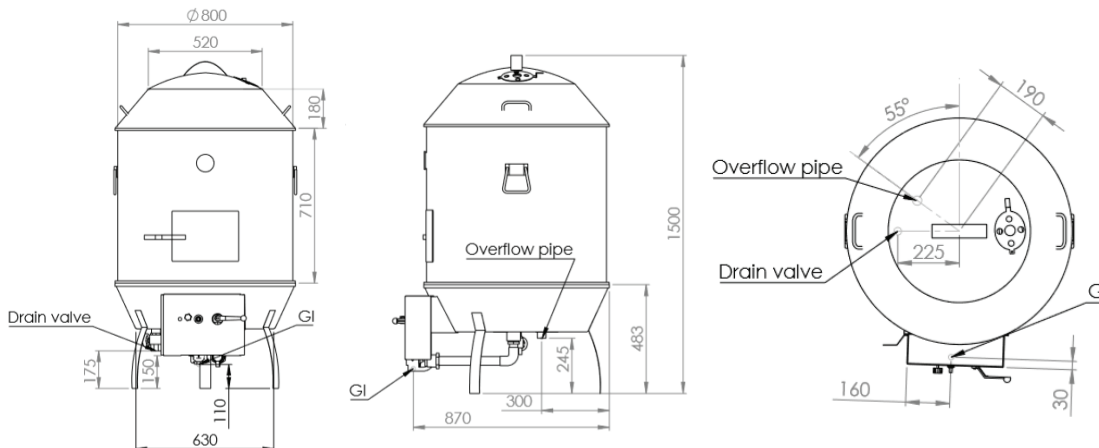

**Due to ongoing product development, product improvement and research, B+S Commercial Kitchens reserves the right to alter specification without notice.*