

TTG OR

OR

TTGOR6
TTGOR9
TTGOR12



- Open front
- Stainless steel hinged rear doors
- Deck forced refrigeration
- Double glazed glass ends
- Two adjustable shelves – flat or angled
- Ticket strips on shelves and base
- Under shelf and canopy LED lights
- Integral condenser
- Pull down night blind
- Perspex riser

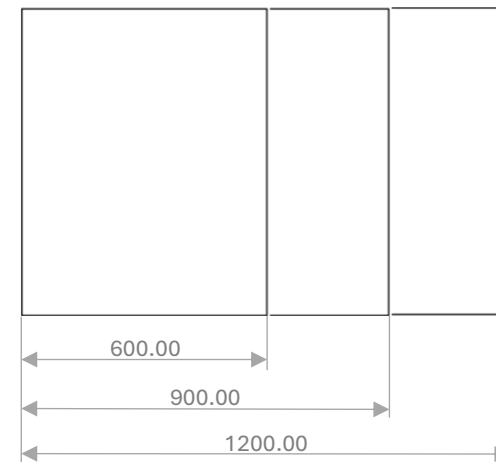
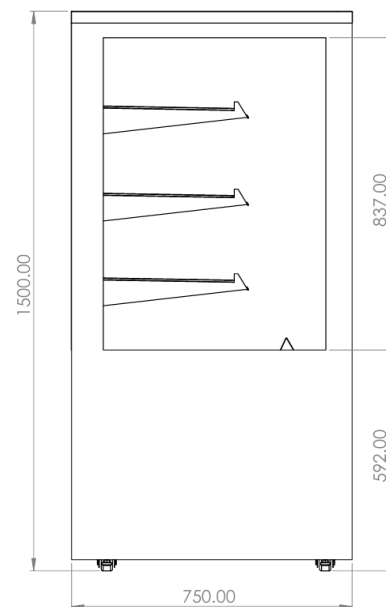

MODEL	CABINET			SHELVING	OPERATING TEMP	SHELF	BASE TRAY	TOTAL FOOD	DISPLAY	FREQUENCY	REFRIGERANT	POWER		CONNECTION POWER CORD 2200MM		VOLTAGE	PACKED FOR SHIPPING				
	LENGTH (MM)	DEPTH (MM)	HEIGHT (MM)									WEIGHT KG	DEG C	W X D	W X D		100MM UNITS	M ²	Hz	KW 230V	AMP
TTGOR6	600	750	1500	192	3 + BASE	3-5	490 X 380	545 X 515	75	0.78	50/60	R290	1.10	6	3 PIN PLUG	3 PIN PLUG	220-240	700	830	1670	223
TTGOR9	900	750	1500	224	3 + BASE	3-5	790 X 380	845 X 515	120	1.25	50/60	R290	1.10	6	3 PIN PLUG	3 PIN PLUG	220-240	1000	830	1670	251
TTGOR12	1200	750	1500	256	3 + BASE	3-5	1085 X 380	1145 X 515	155	1.71	50/60	R290	1.39	7.6	3 PIN PLUG	3 PIN PLUG	220-240	1300	830	1670	284

FREESTANDING

Freestanding cabinets come with default rear venting
Cool intake air comes from both front and rear
and hot exhaust air vents out the rear

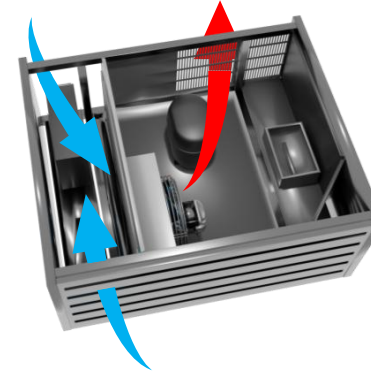

ROLLED INTO BENCH

Cabinets can be rolled into or against a bench,
both intaking and extracting out the rear

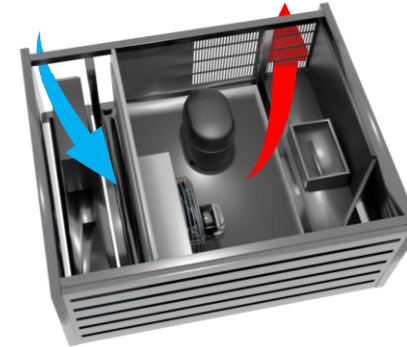

UP AGAINST A WALL

When pushed up against a wall, the baffle can
be swapped to both intake and extract out the
front of the cabinet

**Refer to page 3 for
baffle swapping
information**

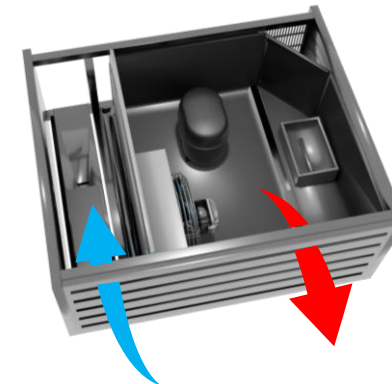

REAR VENTING

Cabinets come standard with the baffle positioned to direct the exhaust airflow out the rear of the cabinet

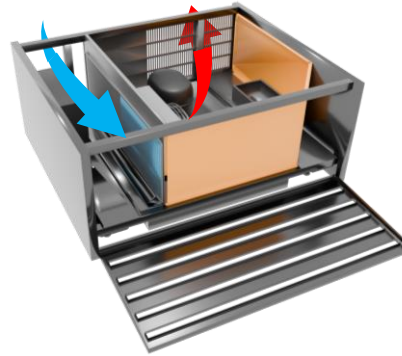

FRONT VENTING

When front venting is required, the baffle can be swapped to direct the exhaust airflow out the front of the cabinet

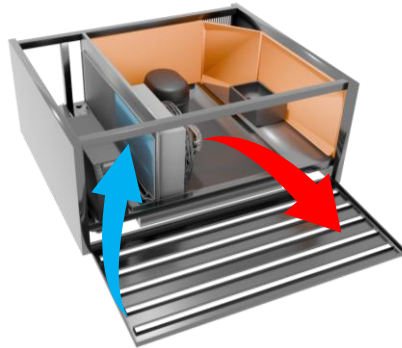

BAFFLE SWAPPING

The baffle comes in two parts which can be unscrewed from the cabinet structure and re-screwed in either a front venting or rear venting position

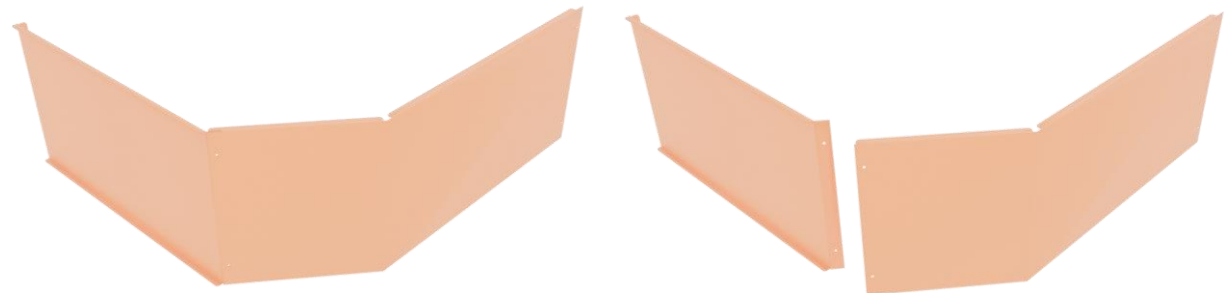

CONTROLLER BOX MOVEMENT

The controller box can be swapped to face the rear or front based on the placement of the cabinet. Standard configuration has the controller box facing the rear. If there is no access to the rear, the controller box can be lifted at an angle off the tray and moved to face the front

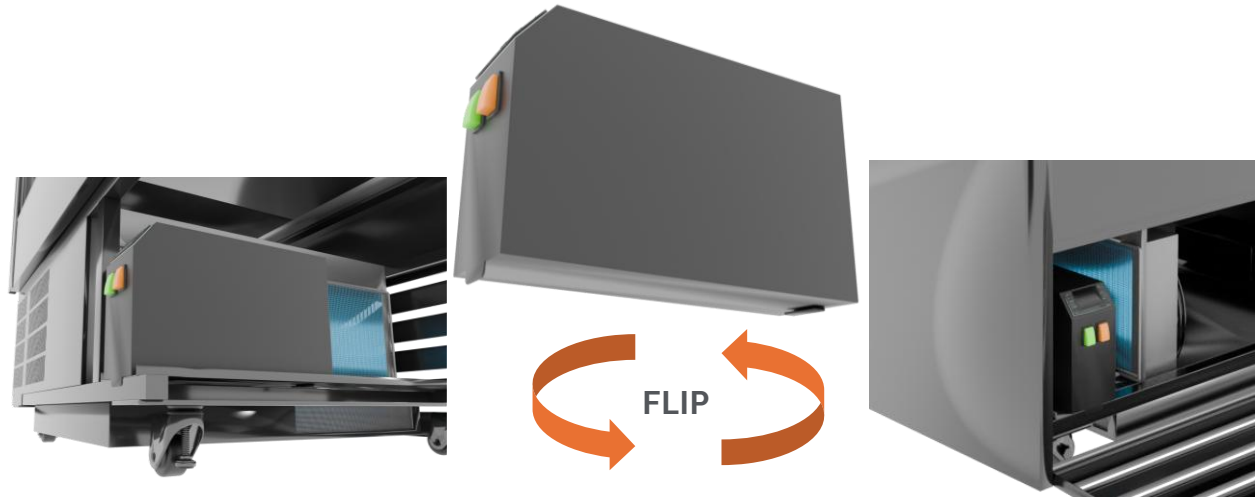

CABINET PLACEMENT

SIDE BY SIDE



Cabinets can be placed side by side without the need for a gap between

BACK TO BACK



Units are front venting, both baffles have been rotated and controller boxes moved to the front

Correct placement ensures optimal performance

MECHANICAL AIRFLOW

Mechanical air flows such as air conditioning vents and fans can disturb the air curtain on open fronted units, causing failure

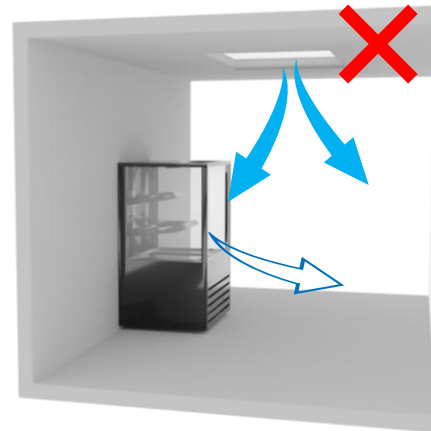

ENVIRONMENTAL CONDITIONS

Heat from other equipment and natural conditions, such as direct sunlight on units, can cause cooling to be dramatically affected, resulting in the compressor overloading

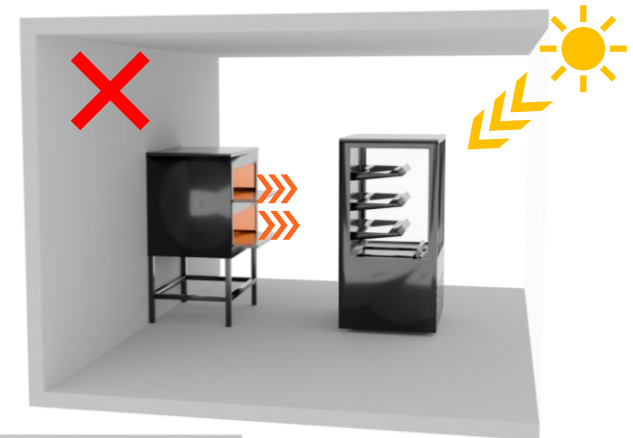

LOCATIONS TO AVOID

- Close to shop front exterior
- In an outside location
- In direct sunlight
- In a high wind
- Near any source producing excessive heat



As standard, units are self evaporating to a receptacle in the condenser unit. In a new site where external drainage is accessible, it is recommended by-passing the evaporation dish. A plastic hose can be attached to the end of the condensate drain and re-directed as shown. This reduces power consumption and will result in less maintenance being required over time.

PLUMBED DRAINAGE TO WASTE

- Plumbed to waste following all local plumbing and building codes
- Building waste by client
- Preferred method in high humidity conditions

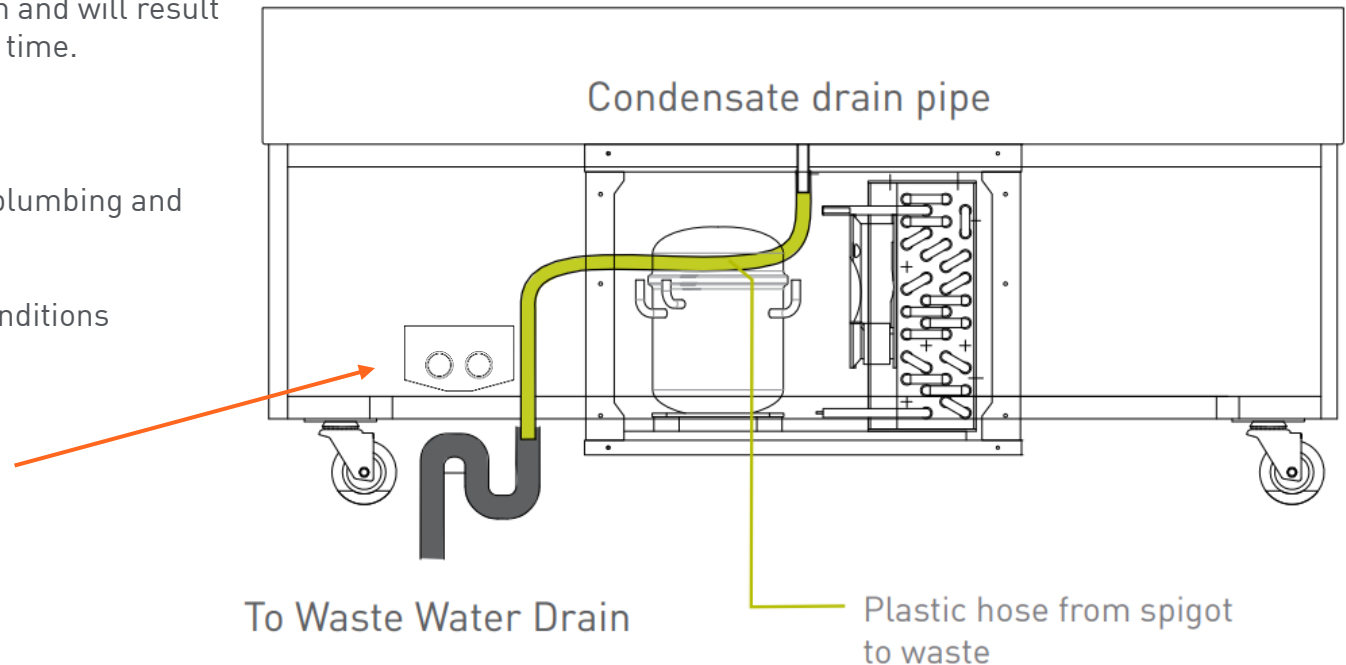
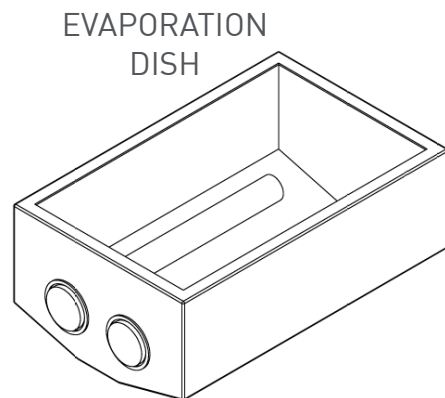

CONDENSER FILTER NET

In all TTGOR models (EXCEPT TTGOR6), there are filter nets covering the condenser face. To ensure excellent performance and maintain the quality of your cabinet, these filter nets should be retrieved and cleaned every 2 weeks

FILTER NET REMOVAL FROM FRONT

- Pull the front grill down
- Pull larger top net out
- Lift angled stainless steel extrusion up and out
- Remove smaller bottom net from stainless steel extrusion
- Brush or vacuum both filter nets

FILTER NET REMOVAL FROM REAR

- Pull larger top net out
- Lift angled stainless steel extrusion up and out
- Remove smaller bottom net from stainless steel extrusion
- Brush or vacuum both filter nets

FILTER NET ASSEMBLY

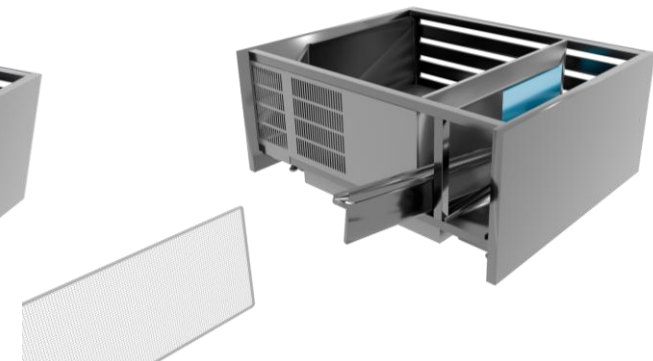
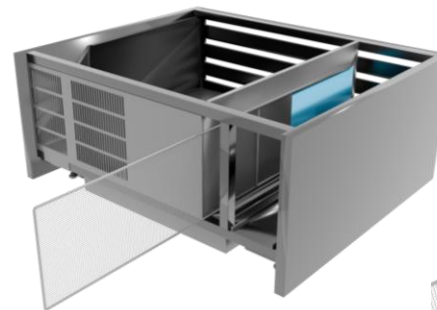
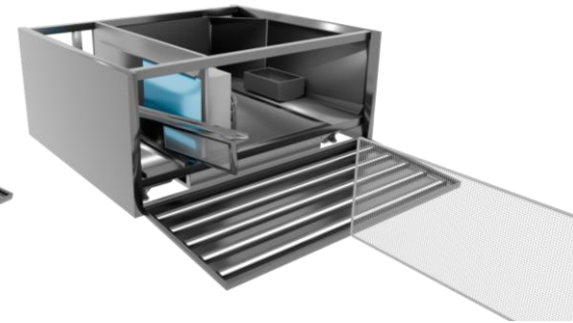
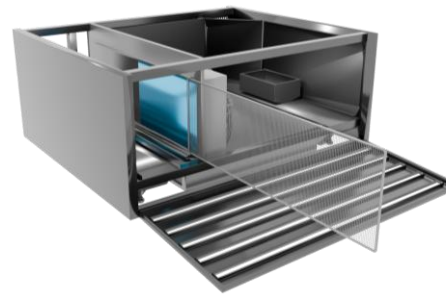
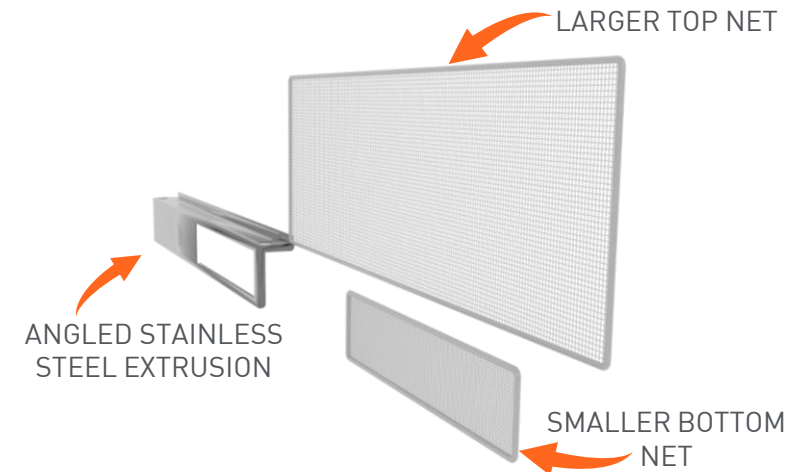
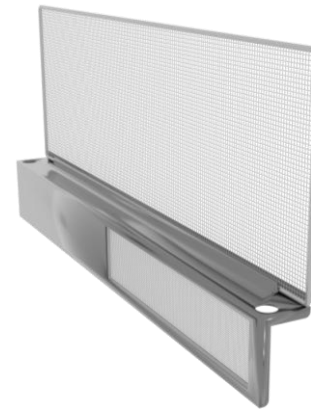

EVAPORATION DRAIN AND FILTER

The evaporation drain is located underneath the base plates and has a filter net to allow for easy cleaning and prevent any debris from clogging the drain pipe



FILTER NET CLEANING

- Lift and remove the base ticket strips and base plates
- Locate the drain point to the rear of the cabinet
- Pull the filter net out of the drain and rinse to clean
- Replace the filter net in the drain
- Replace the base plates and ticket strips



Drain filter

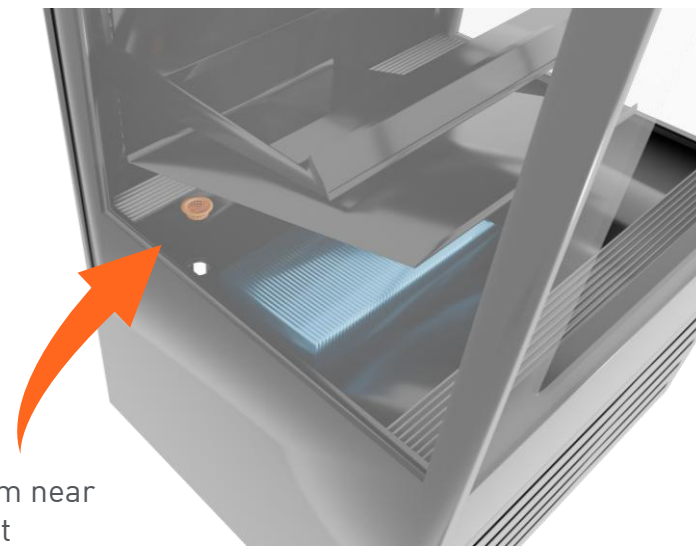



SLIDING FRONT DOOR KIT

Sliding glass doors can be fitted to the front of the cabinet

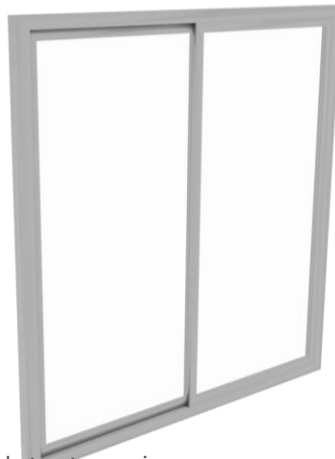

MERCHANDISING BASKET

Merchandising baskets can be installed on the front of a TTGOR

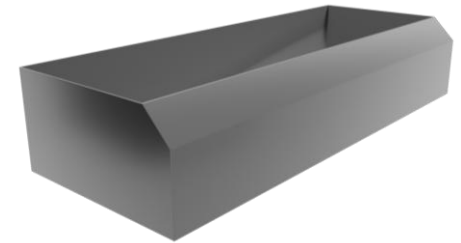

REAR DOOR LOCKING PLATE

Prevents rear doors from opening when cabinet is against a wall or back to back with another cabinet

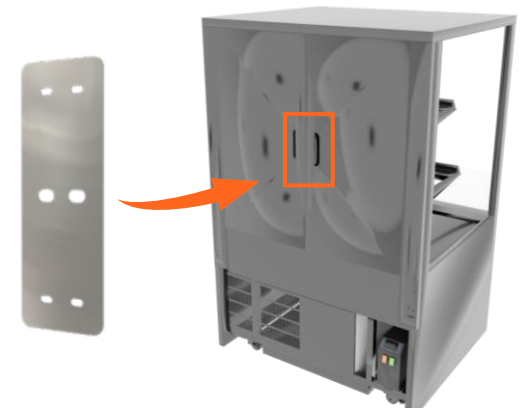

GLASS FLAT OR ANGLED

The shelves can be lifted and pulled out until they lock into their second or third slots, resulting in angled shelves

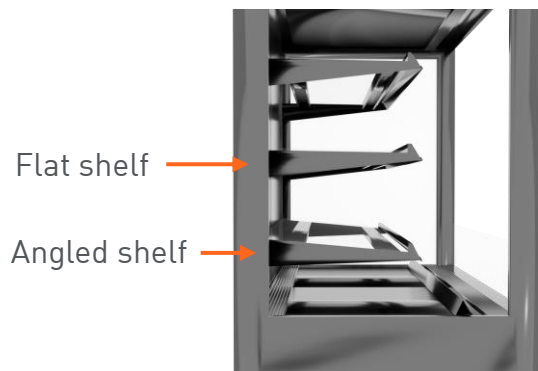

Shelf hooks

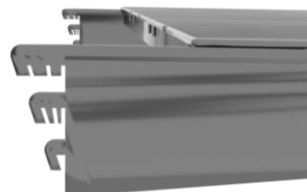

TICKET STRIP

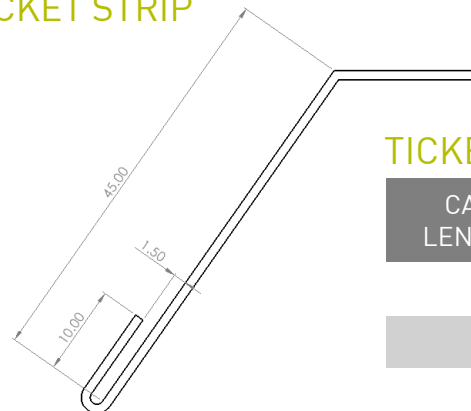

TICKET STRIP LENGTHS

CABINET LENGTH MM	TICKET STRIP LENGTH MM
600	490
900	790
1200	1090

3-SHELF VS 2-SHELF SETUP

The rear vent panels in the TTGOR can be opened and closed depending on whether you are using 2 shelves or all 3 shelves

Slide the knobs on the rear doors up to open the vents and down to close the vents

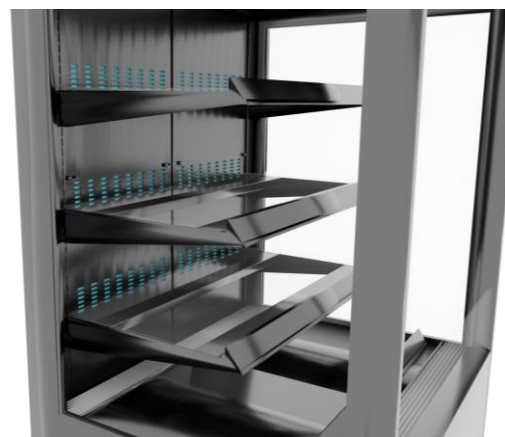
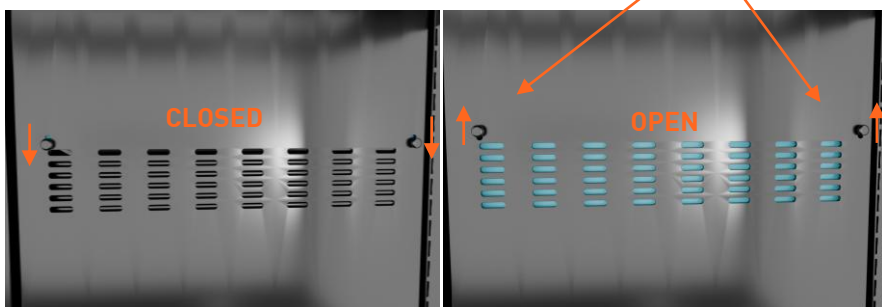

All 3 vents are open in a 3-shelf setup

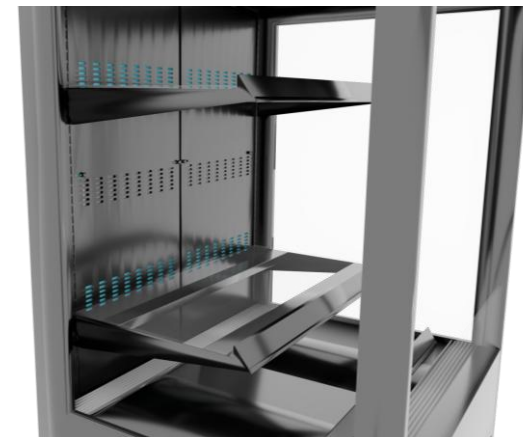

The middle shelf vents are closed when only the top and bottom shelf are being used