

PRODUCT FEATURES

- Heated aluminium base and shelf
- Overhead ceramic heaters and LED lighting
- Digital thermostatic controller
- Ticket strips on shelf and base
- Removable stainless steel dividers to allow for varied spacings

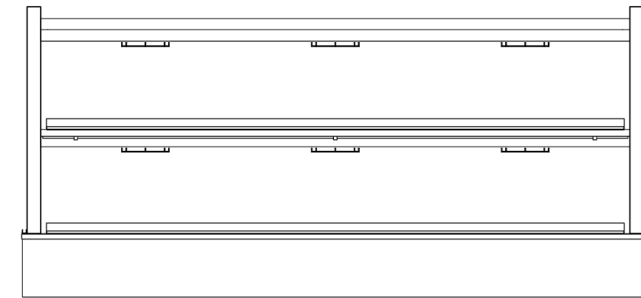
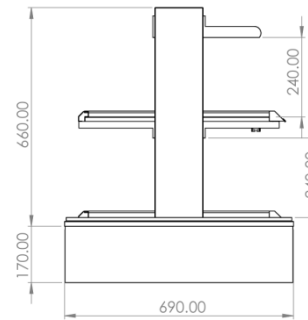
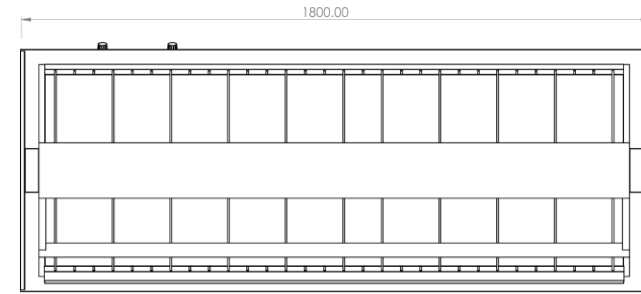

CABINET DIMENSIONS AND SPECIFICATIONS

MODEL	CABINET				BENCH TOP CUT OUT HOLE SIZE	SHELVING	OPERATING TEMP	SHELF	DISPLAY	FREQUENCY	POWER	CONNECTION POWER CORD 2200MM			VOLTAGE	PACKED FOR SHIPPING			
	LENGTH (MM)	DEPTH (MM)	HEIGHT (MM)	WEIGHT (KG)	W X D		DEG C	W X D	M ²	Hz	KW 230V	AMP	NZ/AUS	UK 13 AMP	V	LENGTH (MM)	DEPTH (MM)	HEIGHT (MM)	WEIGHT (KG)
OTSHC18	1800	690	830	189	1774 X 666	1 + BASE	75-85	1660 X 525	1.74	50/60	3.9	16.7	LEAD ONLY	LEAD ONLY	220-240	1900	770	1000	200