

PRODUCT FEATURES

- Heated aluminium base and shelf
- Overhead ceramic heaters and LED lighting
- Digital thermostatic controller
- Ticket strips on shelf and base
- Removable stainless steel dividers to allow for varied spacings

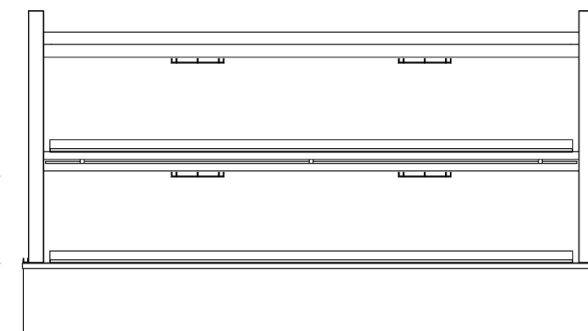
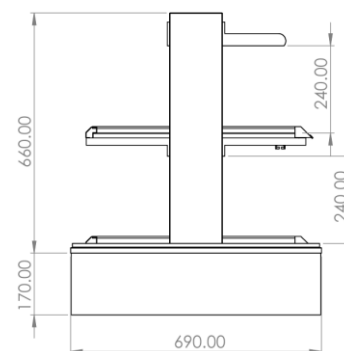
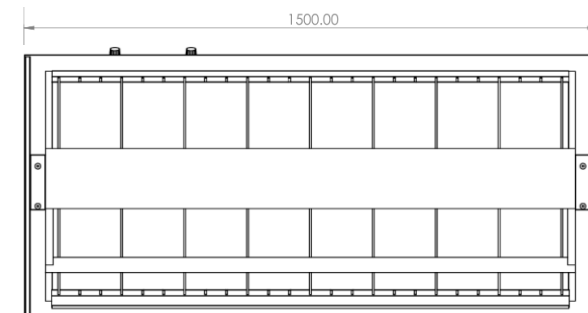

CABINET DIMENSIONS AND SPECIFICATIONS

MODEL	CABINET				BENCH TOP CUT OUT HOLE SIZE	SHELVING	OPERATING TEMP	SHELF	DISPLAY	FREQUENCY	POWER		CONNECTION POWER CORD 2200MM		VOLTAGE	PACKED FOR SHIPPING			
	LENGTH (MM)	DEPTH (MM)	HEIGHT (MM)	WEIGHT KG							W X D	DEG C	W X D	M ²		Hz	KW 230V	AMP	NZ/AUS
OTSHC15	1500	690	830	158	1474 X 666	1 + BASE	75-85	1360 X 525	1.43	50/60	2.6	11.4	LEAD ONLY	LEAD ONLY	220-240	1600	770	1000	166