

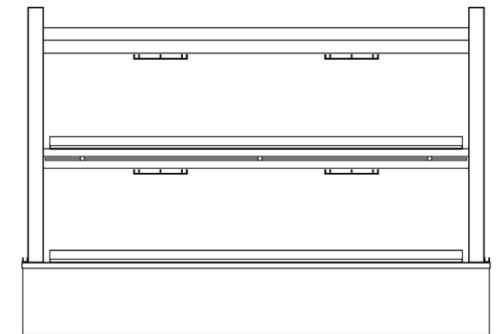

## PRODUCT FEATURES

- Heated aluminium base and shelf
- Overhead ceramic heaters and LED lighting
- Digital thermostatic controller
- Ticket strips on shelf and base
- Removable stainless steel dividers to allow for varied spacings

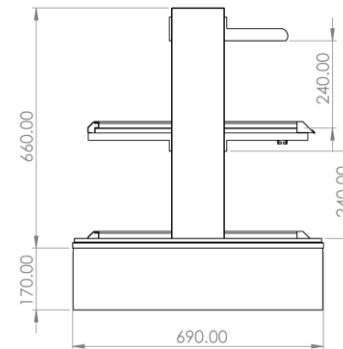
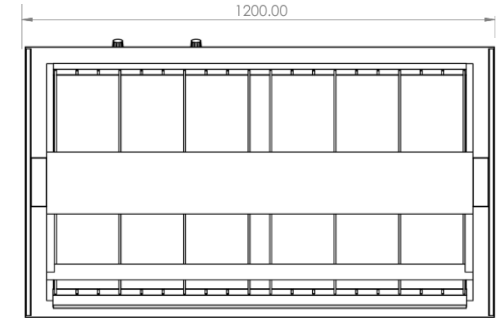

## CABINET DIMENSIONS AND SPECIFICATIONS

MODEL	CABINET				BENCH TOP CUT OUT HOLE SIZE	SHELVING	OPERATING TEMP	SHELF	DISPLAY	FREQUENCY	POWER		CONNECTION POWER CORD 2200MM		VOLTAGE	PACKED FOR SHIPPING			
	LENGTH (MM)	DEPTH (MM)	HEIGHT (MM)	WEIGHT KG							W X D	DEG C	W X D	M <sup>2</sup>		Hz	KW 230V	AMP	NZ/AUS 3 PIN PLUG 15 AMP
OTSHC12	1200	690	830	126	1174 X 666	1 + BASE	75-85	1060 X 525	1.11	50/60	2.1	9.0	3 PIN PLUG 15 AMP	3 PIN PLUG	220-240	1300	770	1000	133