

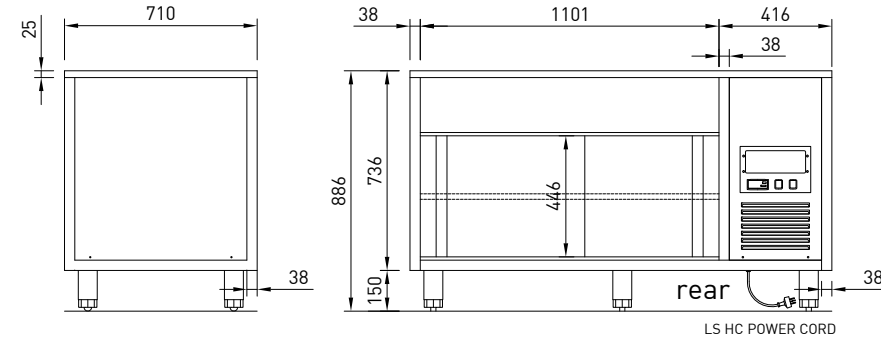

### PRODUCT FEATURES

- Stainless Steel 304 construction
- Fits LSBM & LSCM 4,5,6
- Sliding doors
- Separate hot cupboard controller
- Adjustable feet with recessed rollers for easy manoeuvrability
- Fan forced heat delivery

When Bain Marie unit fitted it must be plumbed for **cold water fill** and **drain** to waste

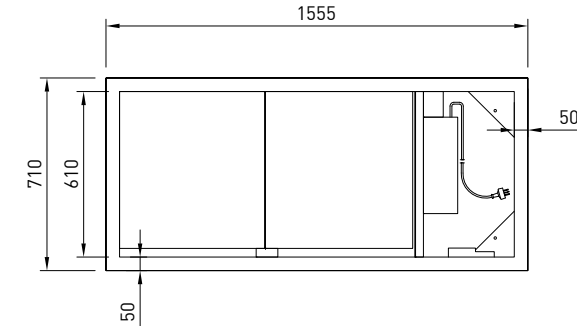
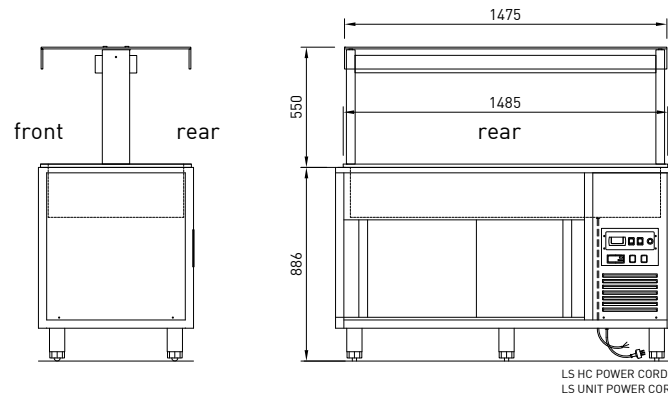

SHOWN WITH LSBM4

LSBM and LSCM units sold separately

### CABINET DIMENSIONS & SPECIFICATIONS

Prior to installation see, installation guidelines, ventilation requirements and drainage options documents

MODEL	CABINET				OPERATING TEMP	SHELF INTERNAL	FITS UNITS	INTERNAL VOLUME M <sup>3</sup>	FREQUENCY	POWER		CONNECTION ELECTRICAL POWER CORD 2200MM		VOLTAGE	PACKED FOR SHIPPING			
	LENGTH [MM]	DEPTH [MM]	HEIGHT [MM]	WEIGHT [KG]						DEG C	1 X MID SHELF W X D	100MM UNITS	KW 230V		AMP	NZ/AUS 3 PIN 10 AMP	UK 13 AMP	LENGTH [MM]
LSCH4	1555	710	886	163	45-75	1080 X 630	LSBM4 LSCM4	0.32	50/60 HZ	1.06	4.6	3 PIN PLUG	3 PIN PLUG	220-240V	1695	820	1044	153