

CABINET DIMENSIONS & SPECIFICATIONS

MODEL	CABINET			WEIGHT KG	BENCH TOP CUT OUT HOLE SIZE	TEMP RANGE DEG C	DISPLAY AREA M2	FREQUENCY	CURRENT WITH OVERHEAD HEATING & LEDS AMPS	POWER WITH OVERHEAD HEATING & LEDES KW 230V	CONNECTION ELECTRICAL POWER CORD 3000MM	VOLTAGE	PACKED FOR SHIPPING			
	LENGTH [MM]	DEPTH [MM]	HEIGHT [MM]										LENGTH [MM]	DEPTH [MM]	HEIGHT [MM]	WEIGHT [KG]
LSCM2	805	690	555	65	775x672	75-95	0.33	50/60 HZ	7.9	1.9	10 AMP 3 PIN PLUG (UK 13 AMP)	220-240V	910	770	410	76
LSCM3	1145	690	555	65	1115x672	75-95	0.51	50/60 HZ	11.7	2.691	15 AMP LEAD ONLY	220-240V	1250	770	410	88
LSCM4	1485	690	555	85	1455x672	75-95	0.68	50/60 HZ	15.7	3.611	20 AMP LEAD ONLY	220-240V	1590	770	410	107
LSCM5	1825	690	555	97	1795x672	75-95	0.86	50/60 HZ	19.6	4.508	20 AMP LEAD ONLY	220-240V	1930	770	410	128
LSCM6	2165	690	555	109	2135x672	75-95	1.04	50/60 HZ	23.5	5.405	30 AMP LEAD ONLY	220-240V	2270	770	410	140

PRODUCT FEATURES

- Ceramic Heated Glass
- Overhead Ceramic Heaters and LED Lighting
- Digital thermostatic controller

LSCM LEFT SIDE ELEVATION

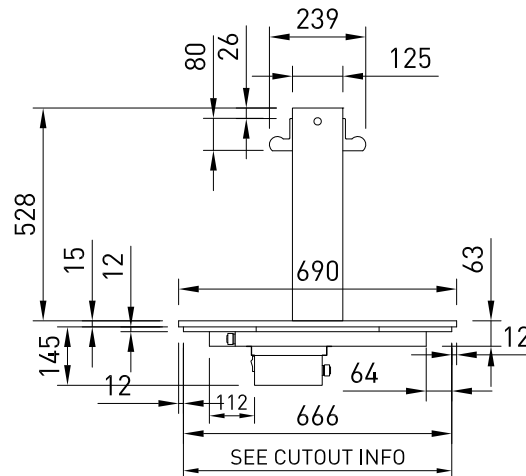

ELECTRICAL POWER

Electrical power cord 3000mm 1 phase connection required.
Unit must be hard wired on site to isolation switch.

INDUSTRY KITCHENS

www.industrykitchens.com.au 1800 611 058

ASSEMBLY REQUIRED

Prior to installation see, installation guidelines, ventilation requirements and drainage options documents

LSCM2

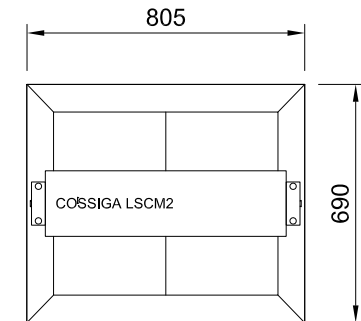
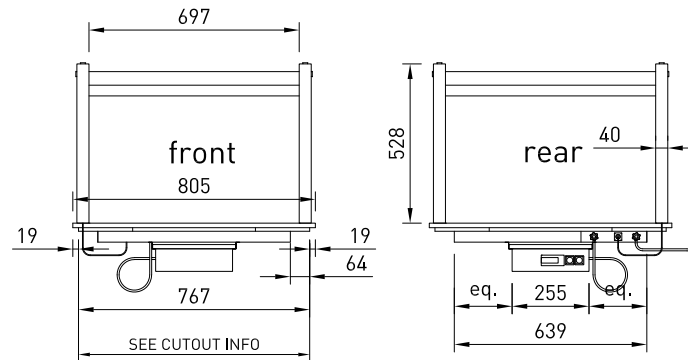
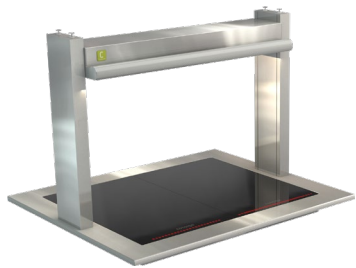

LSCM3

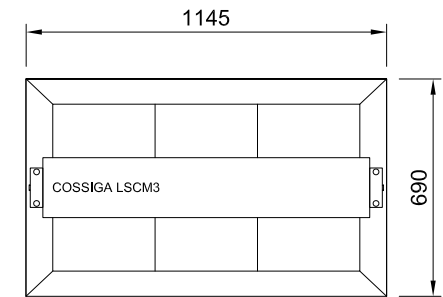
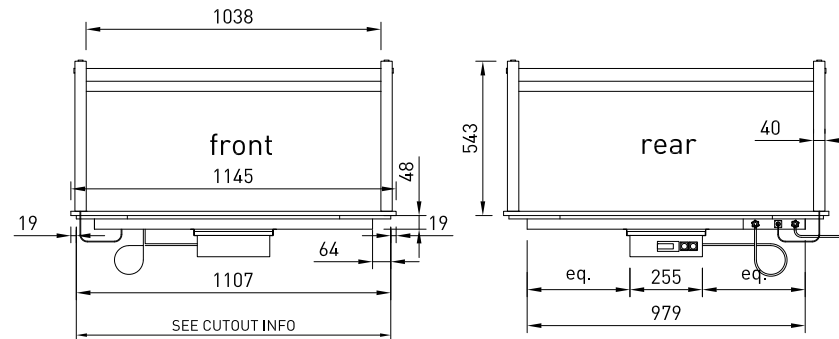
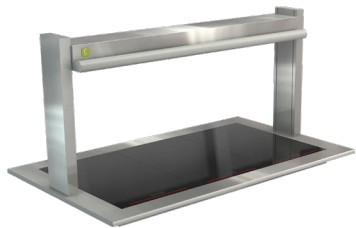

LSCM4

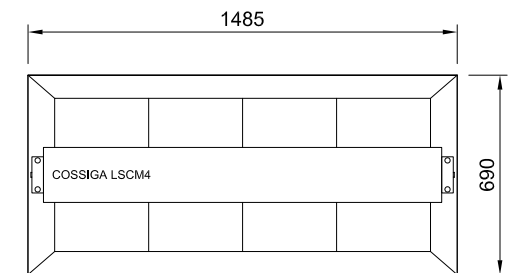
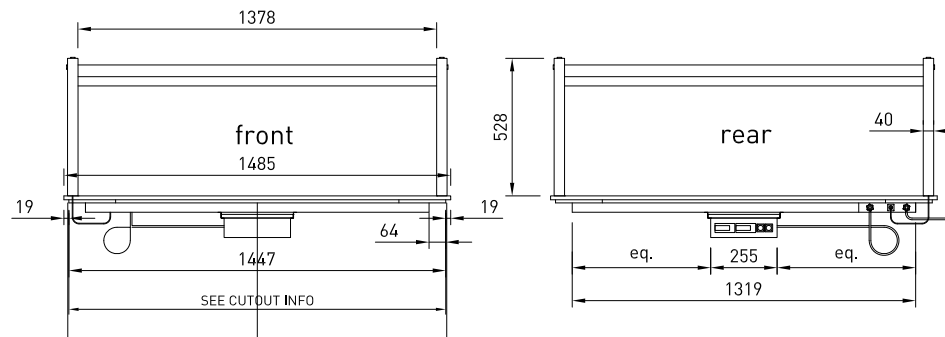
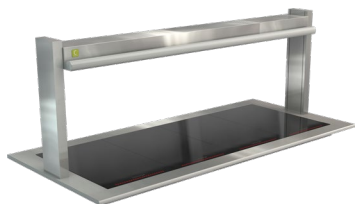

ASSEMBLY REQUIRED

LSCM5

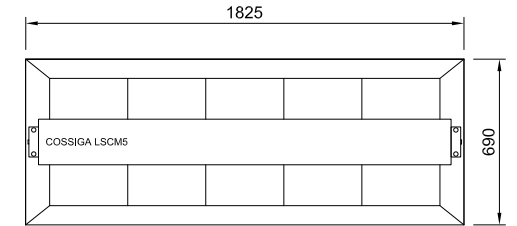
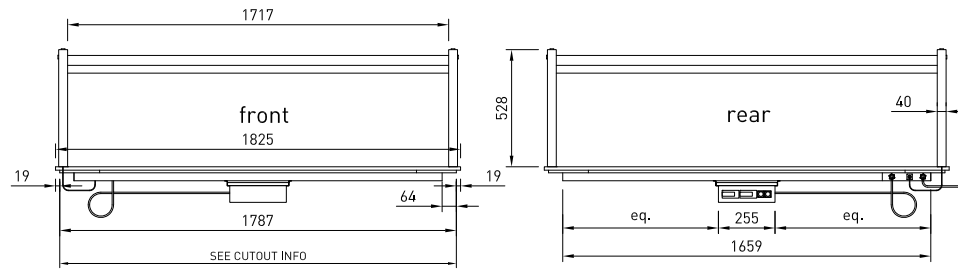
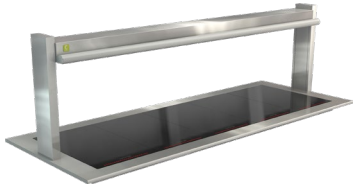

LSCM6

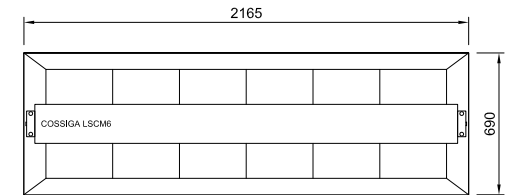
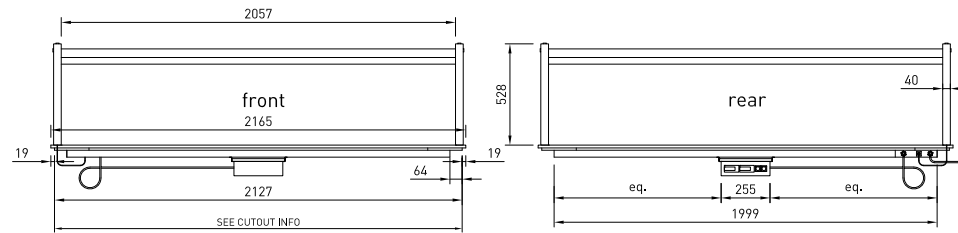
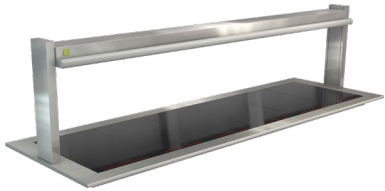

ASSEMBLY REQUIRED