

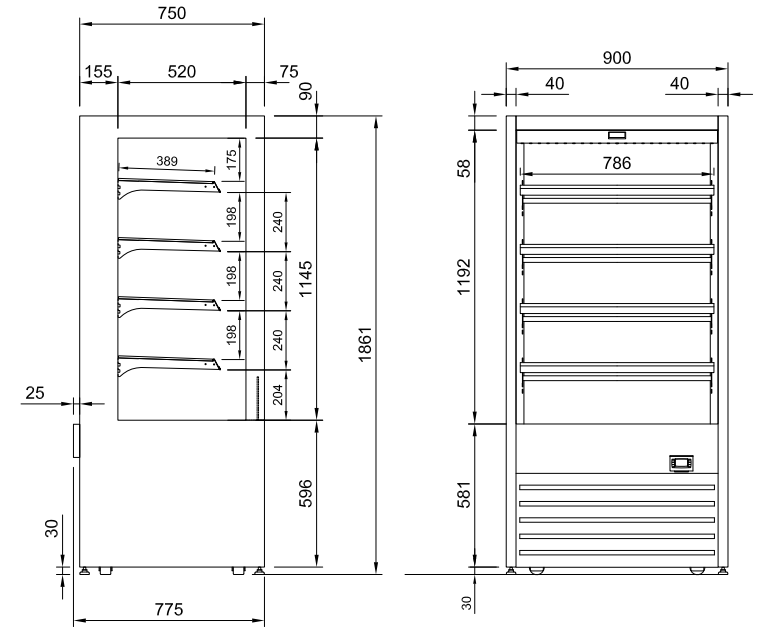

- Stainless steel construction
- Four Stainless steel heated shelves
- Ticket strips on shelves
- Shelf mounted air curtains
- Forced air circulation
- Under shelf and canopy LED lights
- Hinged Glass front doors
- Opening front grille panel
- Roll in on castors with adjustable feet
- ECO mode turns off heat on two bottom shelves plus the base

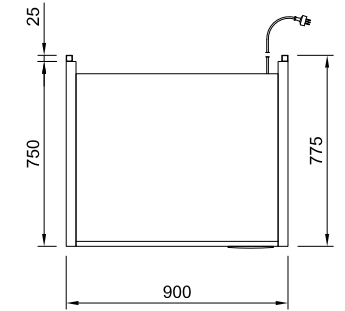

CABINET DIMENSIONS & SPECIFICATIONS

Prior to installation see, installation guidelines documents

MODEL	CABINET				SHELVING	OPERATING TEMP	SHELF	BASE TRAY	DISPLAY	FREQUENCY	OPERATING CURRENT	POWER	CONNECTION		VOLTAGE	PACKED FOR SHIPPING			
	LENGTH [MM]	DEPTH [MM]	HEIGHT [MM]	WEIGHT [KG]									DEG C	W X D		W X D	M ²	Hz	Amps
DTGHT9	900	775	1860	178	4 + BASE	70 -85	786 X 387	820 X 533	1.63	50/60 HZ	10.5	2.33	NZ/AUS	UK AMP	220-240V	1000	830	2030	215

Maximum shelf load weight 15kg spread evenly