

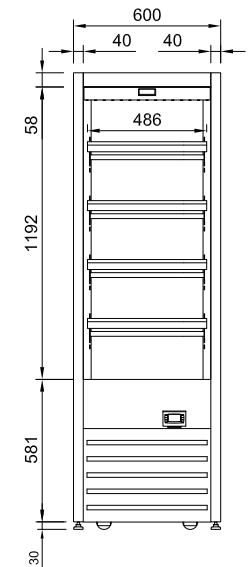

- Stainless steel construction
- Four Stainless steel heated shelves
- Ticket strips on shelves
- Shelf mounted air curtains
- Forced air circulation
- Under shelf and canopy LED lights
- Reversible hinged glass front door
- Opening front grille panel
- Roll in on castors with adjustable feet
- ECO mode turns off heat on two bottom shelves plus the base

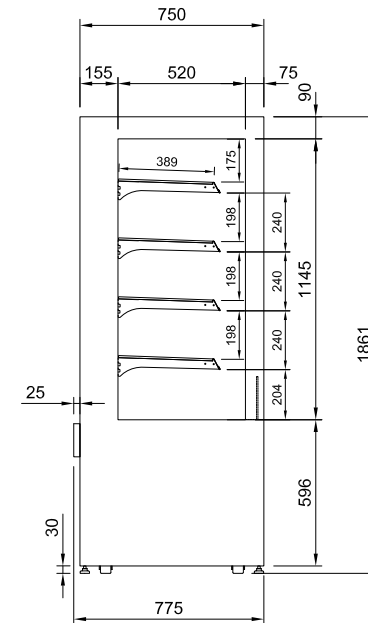
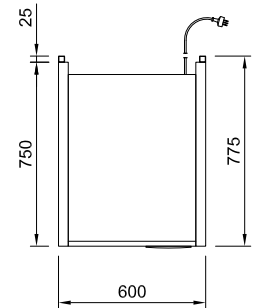

CABINET DIMENSIONS & SPECIFICATIONS

Prior to installation see, installation guidelines documents

MODEL	CABINET				SHELVING	OPERATING TEMP	SHELF	BASE TRAY	DISPLAY	FREQUENCY	OPERATING CURRENT	POWER	CONNECTION		VOLTAGE	PACKED FOR SHIPPING			
	LENGTH [MM]	DEPTH [MM]	HEIGHT [MM]	WEIGHT [KG]									DEG C	W X D		W X D	M ²	Hz	Amps
DTGHT6	600	775	1860	139	4 + BASE	70 -85	486 X 387	520 X 533	0.98	50/60 HZ	7.2	1.9	NZ/AUS	UK AMP	220-240V	700	830	2030	175

Maximum shelf load weight 15kg spread evenly