

BTGHT15 FREE-STANDING MULTIDECK HEATED

BTGHT15



PRODUCT FEATURES

- Deck forced heating
- Single glazed
- Sliding rear doors
- Solid front or sliding front doors
- Solid front that hinges at base
- Four adjustable shelves - flat or angled
- Ticket strips on shelves and base
- Under shelf and canopy LED lights

Maximum shelf load weight 15kg spread evenly

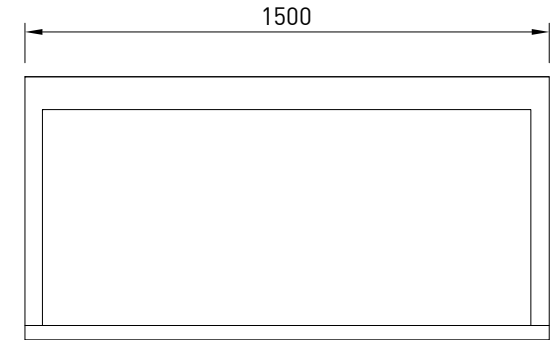

BTGHT15-SD

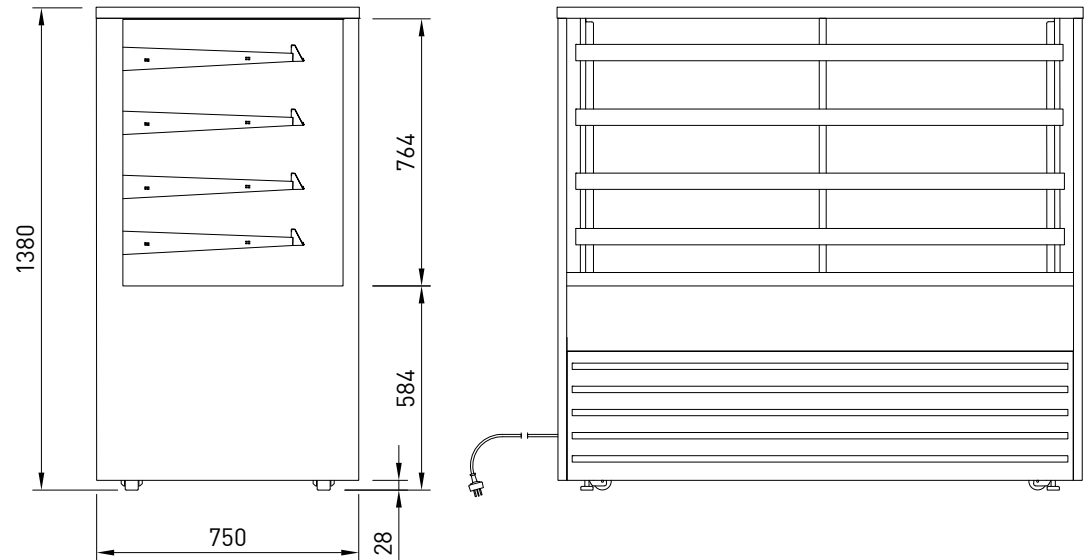

CABINET DIMENSIONS & SPECIFICATIONS

Prior to installation see, installation guidelines, ventilation requirements and drainage options documents

MODEL	CABINET				SHELVING	OPERATING TEMP	SHELF	BASE TRAY	TOTAL FOOD	DISPLAY M ²	INTERNAL VOLUME M ³	FREQUENCY	POWER		CONNECTION ELECTRICAL POWER CORD 2200MM		VOLTAGE	PACKED FOR SHIPPING			
	LENGTH [MM]	DEPTH [MM]	HEIGHT [MM]	WEIGHT [KG]									DEG C	W X D	W X D	100MM UNITS		KW 230V	AMP	NZ/AUS 3 PIN	UK 13 AMP
BTGHT15 BTGHT15-SD	1500	750	1380	214	4 + BASE	75-85	1390 X 445	1440 x 510	355	3.20	0.75	50 Hz	2.66	11.6	15 AMP	3 PIN PLUG	220-240V	1600	830	1550	222