

Convotherm maxx pro easyTouch Combi Steamer

CXEBT20.10D ELECTRIC BOILER 20 x 1/1 GN

- Boiler system
- Natural Smart Climate™ (ACS+) cooking methods: Steam, Combi-steam, Convection
- Natural Smart Climate™ extra functions:
 - Crisp&Tasty - 5 moisture-removal settings
 - BakePro – 5 levels of traditional baking
 - HumidityPro - 5 humidity settings
 - Controllable fan – 5 speed settings
- easyTouch 10" TFT HiRes glass touch display (capacitive)
- ConvoClean+ fully automatic cleaning system with eco, regular and express modes, including optional single-dose dispensing
- HygieniCare
- WiFi and Ethernet interface (LAN)
- USB port integrated in the control panel
- Steam generated by high-performance boiler outside the cooking chamber
- Double glazed appliance door
- Right-hinged appliance door
- Disappearing door



Standard Features

- Cooking methods:
 - Steam (30-130°C) with guaranteed steam saturation
 - Combi-steam (30-250 °C) with automatic moisture control
 - Convection (30-250 °C) with optimised heat transfer
- Operation of easyTouch user interface:
 - 10" TFT HiRes glass touch display (capacitive)
 - Smooth-action, quick reacting scrolling function
- Climate Management
 - Natural Smart Climate™ (ACS+), HumidityPro, Crisp&Tasty
- Quality Management
 - Airflow Management, BakePro, Multi-point core temperature probe
 - Preheat and cool down function
- Production Management
 - Automatic cooking with Press&Go with up to 399 cooking profiles
 - Integrated cookbook with 7 different categories
 - TrayTimer – load management for different products at the same time (manual mode)
 - TrayView – load management for automatic cooking of different products using Press&Go
 - Favourites management
 - HACCP data storage
 - USB port
 - ecoCooking – energy-save function
 - LT cooking (low temperature cooking) / Delta-T cooking
 - Cook&Hold – cook and hold in one process
 - Autostart
 - Regenerate+ - flexible multi-mode rethermalisation function with preselect
- Cleaning Management:
 - ConvoClean+ - fully automatic cleaning system
 - Quick access to individually created and saved cleaning profiles
 - Cleaning scheduler
 - FilterCare interface

- HygieniCare: safety by antibacterial surfaces
 - Hygienic Steam Function
 - Hygienic Handles
 - SteamDisinfect
- Door handle with sure-shut function
- Adjustable appliance feet, from 100 mm to 125 mm
- Integrated recoil hand shower
- Device status ground LED
 - Green = cooking and flashing "end of cooking"
 - Yellow = pre-heat and open door
 - Red = error
- Wheel-in rails with optimal shape and colour coding
- Integrated preheat bridge

Options

- Steam and vapour removal (built-in condensation hood)
- Sous-vide sensor, with external socket
- Core temperature sensor, with external socket
- Marine model
- Available in various voltages
- Quality Management: ConvoSmoke – built-in food-smoking function (Hot-Smoke – loading capacity reduced)
- Prison Version

Accessories

- ConvoVent 4 condensation hood with grease filter
- ConvoVent 4+ condensation hood with grease and odour filter
- Banquet system package: plate rack, mobile shelf rack, transport trolley, thermal cover (individual items are available)
- Care products for ConvoClean+ fully automatic cleaning system (multiple and single-dose dispensing)
- 3rd front foot: stability and height compensation
- Signal Tower – external operating state indicator
- Production Management: KitchenConnect (Wifi/LAN) network solution from Welbilt for updating and monitoring appliances from anywhere

Convothem maxx pro easyTouch Combi Steamer

CXEBT20.10D ELECTRIC BOILER 20 x 1/1 GN

Front view

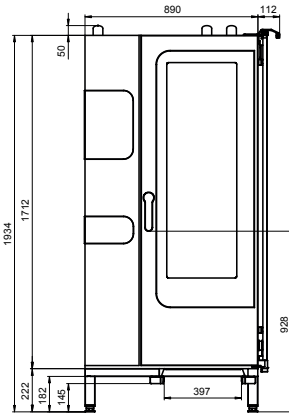

View from above with wall clearances

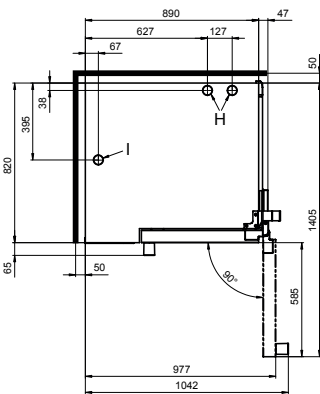

Connection positions in appliance floor

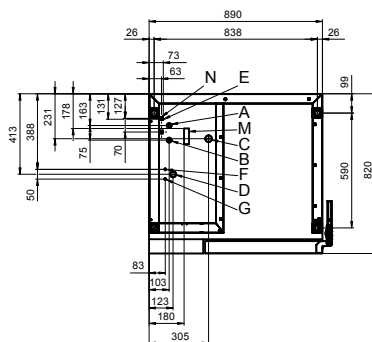

- A Water connection (for boiler)
- B Water connection (for cleaning, recoil hand shower)
- C Drain connection DN 50
- D Electrical connection
- E Equipotential bonding
- F Rinse aid connection
- G Cleaning agent connection
- H Air vent Ø 50 mm
- I Dry air intake Ø 50 mm
- M Safety overflow 80 mm x 25 mm
- N RJ45 Ethernet port

DIMENSIONS

Width	1002mm
Depth	820 mm
Height	1934 mm
Weight	292 kg

PACKED DIMENSIONS

Width	1165 mm
Depth	970 mm
Height	2150 mm
Weight (including cleaning system)	332 kg

Safety clearances*

Rear	50 mm
Right	50 mm
Left (larger recommended for servicing)	50 mm
Top (for ventilation)	500 mm

*Heat sources must lie at a minimum distance of 500 mm from the appliance.

INSTALLATION REQUIREMENTS

For precise installation instructions please refer to the units installation manual

LOADING CAPACITY

Max. number of food containers	
Shelf distance	68mm
GN 1/1 (with standard loading trolley)	20
600 x 400 baking sheet (with appropriate loading trolley)	17
Max. loading weight GN 1/1 / 600 x 400	
Per combi steamer	100 kg
Per shelf	15 kg

ELECTRICAL SUPPLY

3N~ 400V 50/60Hz (3P+N+E)	
Rated power consumption	38,9 kW
Rated current	56,2 A
Fuse	63 A
RCD (GFCI), frequency converter (singlephase)	Type A (recommended), type B/F (optional)

Special voltage options available on request.

Connection to an energy optimisation system as standard.

WATER CONNECTION

Water supply

2 x G 3/4" permanent connection, optionally including connecting pipe (min. DN13 / 1/2")

Flow pressure 150 - 600 kPa (1.5 - 6 bar)

Appliance drain

Drain version Permanent connection (recommended) or funnel waste trap DN50 (min. internal Ø: 46 mm)

Type DN50 (min. internal Ø: 46 mm)

Slope for waste-water pipe min. 3.5% (2°)

WATER QUALITY

Drinking water

Total hardness

Cleaning, recoil hand shower, boiler 4-20 °dh / 70-360 ppm / 7-35 °TH / 5-25 °e

Properties

pH	6.5 - 8.5
Cl ⁻ (chloride)	max. 60 mg/l
Cl ₂ (free chlorine)	max. 0.2 mg/l
SO ₄ ²⁻ (sulphate)	max. 150 mg/l
Fe (iron)	max. 0.1 mg/l
SiO ₂ (silicate)	max. 13 mg/l
NH ₂ Cl (monochloramine)	max. 0.2 mg/l
Temperature	max. 40°C
Electrical conductivity	min. 20 µS/cm

EMISSIONS

Heat output

Latent heat 6900 kJ/h / 1.92 kW

Sensible heat 8900 kJ/h / 2.47 kW

Waste water temperature max. 80 °C

Noise during operation max. 70 dBA



Australia
moffat.com.au

New Zealand
moffat.co.nz

Australia
Moffat Pty Limited

Victoria/Tasmania
740 Springvale Road
Mulgrave, Victoria 3170
Ph 03-9518 3888
Fax 03-9518 3833
vsales@moffat.com.au
www.moffat.com.au

New South Wales
Ph 02-8833 4111
nswsales@moffat.com.au

South Australia
Ph 03-9518 3888
vsales@moffat.com.au

Queensland
Ph 07-3630 8600
qldsales@moffat.com.au

Western Australia
Ph 08-9413 2400
wasales@moffat.com.au

New Zealand
Moffat Limited

Christchurch
45 Illinois Drive
Izone Business Hub
Rolleston 7675
New Zealand
Telephone +64 3-983 6600
Facsimile +64 3-983 6660
sales@moffat.co.nz

Auckland
Ph +64 9-574 3150
sales@moffat.co.nz

In line with policy to continually develop and improve its products, Moffat Limited reserves the right to change specifications and design without notice.

© Copyright Moffat Ltd
AN.CON.S.01.23

