

XVL 1 - XVL 3

Steel



**INDUSTRY
KITCHENS**

www.industrykitchens.com.au 1800 611 058



CARPIGANI

CARPIGIANI **SOFT SERVE & SHAKE CONSULTING**

CARPIGIANI SOFT SERVE & SHAKE CONSULTING consultants can help you transform your idea into a successful business!



Efficient
Fundamental
High performance





PERFORMANCE AND QUALITY

Produce Soft Serve Gelato, Ice Creams, Sorbets and Frozen Yogurt. Thanks to the independent cylinders, in the XVL 3 it is possible to simultaneously mix products of different consistencies.



Creamy Soft Serve Gelato

Thanks to the H-O-T system and to the type of feed (gravity or pump) it is possible to set the desired consistency for creamy ice creams, from a delicate Vanilla to a robust chocolate.



Soft Serve Sorbets

Choose the desired consistency of the Soft Serve Sorbets, thanks to the H-O-T system and to the type of feed system used (gravity or pump).



Frozen Yogurt

Choose the desired consistency of the Frozen Yogurt, to produce a classic frozen yogurt or a unique soft serve gelato yogurt. Thanks to the H-O-T system and to the type of feed system used (gravity or pump).



Custom shape Gelato

Legend: Optional ONLY upon purchase Optional available even after purchase



PERFORMANCE AND QUALITY

Star Door

Star Door allows the use of the new nozzles and the single-portion kit.



Monoportion kit.

Kit of nozzles suitable for filling small cups, cannoli's and other frozen dessert monoportions.



Blender. Integrated blender uses disposable spoons to conveniently and hygienically mix toppings or syrups into a soft serve cup.



Nozzles. Customize the Soft Serve by choosing new and unique nozzles that fit your style.



Gravità - Gravity

Pompa - Pump

Pump / Gravity kit (only for XVL 3 P models using the POM Beater). Run one pump- & one gravity- fed cylinder at the same time.



Winter Door (only for XVL 3 models).

This unique door is composed of two separate doors. Giving the user the freedom to operate one or both cylinders or even operate one cylinder while cleaning the other. The twist door is inhibited.





PERFORMANCE AND QUALITY

Hard-O-Tronic®. The electronic control system that allows you to change the consistency of the Soft Serve in a simple and fast way.

Choice of MIX FEEDING SYSTEM

Submerged Pump - Version P

Ideal for creating dry and compact Soft Serve. Pressurized steel pump with advanced thermoplastic polymer gears. Thanks to the holes in the pump regulator, it is possible to obtain 40-80% overrun. It is possible to adjust the overrun even when the tank is full!

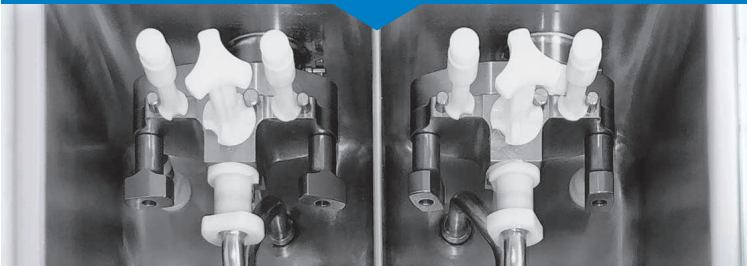

Gravity - Version G

Ideal for a dry and compact Soft Serve with up to 40% overrun. The different diameters of the feeding tube holes naturally dose the mixture with air. It is possible to adjust the overrun even when the tank is full, using the overrun adjuster, thanks to the feeding tube holes, which are above and below the mix.



BEATER Choice

2E-RSI High Efficiency Beater

Ideal for soft and Creamy Soft Serve. Stainless steel beater with plastic scrapers and removable shaft.



High Efficiency Beater in POM

Convenient Monobloc beater in food-grade plastic. Standard in gravity versions.



1.75 L Direct expansion cylinder

Optimized refrigeration process. Faster freezing times & more energy savings. Pre-loading operation is simple and safe, thanks to the new position of the feed hole.



Legend: Optional ONLY upon purchase Optional available even after purchase



CONVENIENCE

New solutions for maximum **convenience during use**

Tank Agitator

Prevents product stratification during storage and improves heat exchange during pasteurization.



Adjustable dispensing speed

Adjustable delivery flow to meet all volume and speed needs.

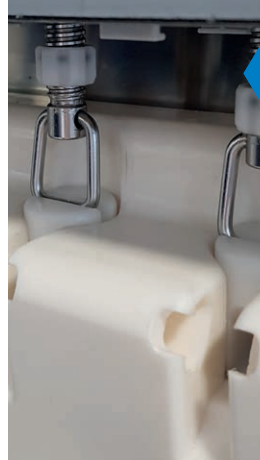

Self Closing

User-friendly Self Closing levers automatically close to stop the flow of product, eliminating any waste. Automatic self closing levers are easy to assemble & disassemble. Ideal for rotating staffs.



Pinless Aluminum levers

When the machine is not manned, the levers can be removed and reassembled quickly, without the use of tools.



Dry Filling system

Automatic dry filling system, allows users to automatically add water as well as mix powder mixtures directly in the tank, saving time, space and reducing the possibility of dosing errors.

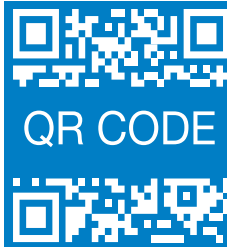

QR CODE

Scan the **QR Code** on the front of the machine to access the most up to date equipment information: Instruction Manual, Carpi Care kit & Carpi Clean kit.

Versatile machine* (only for XVL 3 models).

Thanks to three different functions, it is possible to choose the side on which you want to operate. Left side only or right side only in low season, both during high productivity.

* With the Optional Winter Door.



SAVINGS

New **high-performance** electric gearmotors and condensers

Independent pump transmission. (P version). Extends the life of the pump and gears. Ensures flexibility with high performance.

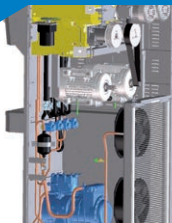

Choice of **COOLING**



Water Cooled machine

Refrigeration system is cooled thanks to the inlet and outlet water circuit, conveniently located at the rear of the machine.

Air cooled machine

Thanks to the rear chimney, it is possible to optimize the installation space and to place the machines side by side.



Minimum residue of mixture in the tank (0.2 liters.) Thanks to the conformation with depression in the rear part of the tank, during the cleaning phase the waste of the mixture is minimal.



SAFETY

More operational safety and **more control** during production



Ergonomic design. Reduced risk of injury, with corners even rounder where the operator works.

Black-out and water outage

After a power or water failure, if the temperature-time parameters guarantee that the mixture has not undergone any alteration, the machine resumes the program in progress. Otherwise, if the machine is self-pasteurizing, a pasteurization cycle is automatically started, warning the operator with a message on the display. In the case of the non self-pasteurizing version, the machine requires washing.



Teorema

Guarantees facilitated assistance by providing on-line monitoring and diagnosis on a tablet, phone or PC wherever you are.



Button lock

For added security, the display buttons can be locked to prevent accidental errors.





HYGIENE

Easy cleaning,
guaranteed hygiene

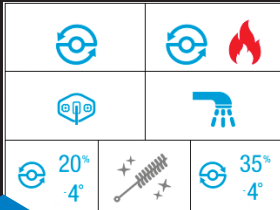

Multifunctional Cleaning Button

Possibility to activate or deactivate the pump and the beater individually or together according to cleaning needs. One of the functions is hot cleaning. By simultaneously activating the beater and the heating of the cylinder surface, the production grease residues are quickly dissolved.

Wash kit

Water Tap is added over the tank to facilitate cleaning.

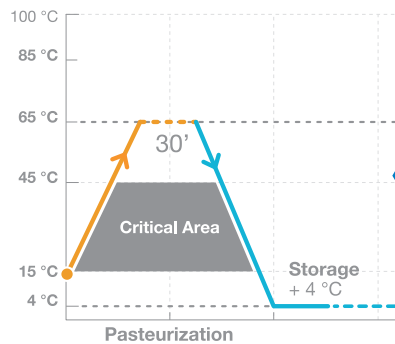

With the automatic **self-pasteurization (optional only for XVL 1 and XVL 3)** system you can choose when to wash the machine up to a maximum interval of 42 days. As a further guarantee of hygienic safety, if the operator does not perform the complete cleaning at the end of the set days, the machine goes into automatic block.

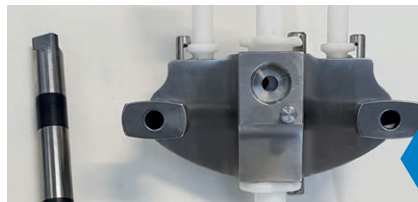

Removable pump shaft

It simplifies cleaning procedures and guarantees maximum hygiene and reliability.

Carpi Care kit



Custom kits, designed to always keep your machine hygienically perfect.

Carpi Clean kit



Scheduled start. Set the production, pasteurization, and storage programs to automatically run at a convenient time for you, such as overnight, to be fully operational the next day.

Ergonomic lid

Ergonomic transparent tank lid for easy tank inspection.



MACHINE CONFIGURATION

TANK CONFIGURATION

CHOOSE THE PRODUCT FEED SYSTEM

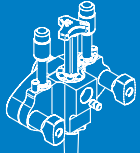

Pump

Optional



Gravity

Optional



Wash kit



Dry filling system

BEATER & DOOR CONFIGURATION

CHOOSE THE TYPE OF BEATER



2E-RSI Beater

Optional

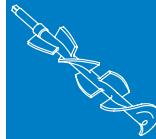

POM Beater

Optional

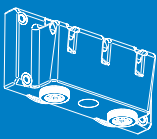

Winter Door
(only for XVL 3 models)

Optional



Nozzles



Monoportion kit

MACHINE CONFIGURATION

TECHNICAL CONFIGURATION

CHOOSE THE TYPE OF CONDENSATION

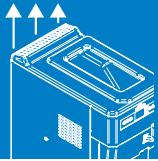

Air Cooled machine
(only for XVL 1 Counter models)

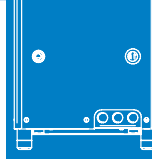

Water Cooled machine
(only for XVL 1 Counter models)

CHOOSE THE TYPE OF CONDENSATION

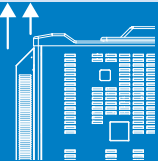

Air Cooled machine
(for XVL 1 and XVL 3 models)

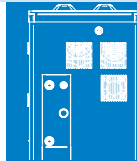

Water Cooled machine
(for XVL 1 and XVL 3 models)

Optional

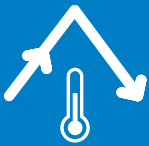

Self-Pasteurization
(for XVL 1 and XVL 3 models)

CHOOSE THE TYPE OF POWER SUPPLY



Power supply
Single-phase / Three-phase

ACCESSORIES CONFIGURATION

Optional

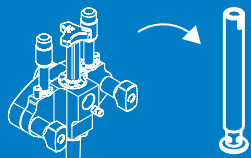

Pump kit / Gravity kit
(only for XVL 3 P models using the POM Beater)

Optional



Teorema

Optional



Blender

WHO WE ARE

Carpigiani Services. Always by your side! The extensive Carpigiani service network is at your disposal with a widespread assistance network that guarantees a wide coverage of the territory with over 480 authorized service centers and 1500 specialized technicians around the world, for over 70 years guaranteeing a widespread, global presence. Carpigiani Services ensures rapid and professional assistance.

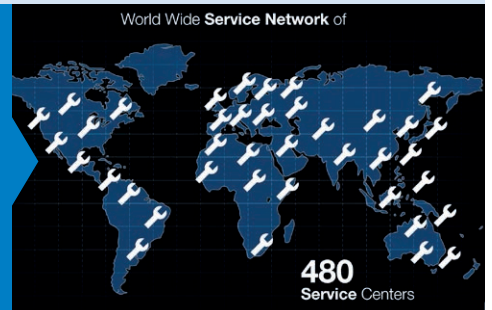

WHAT WE OFFER

Original spare parts. Carpigiani original spare parts, manufactured in compliance with national and international food safety regulations, ensure the durability of the components and extend the life of the machine. They are the only ones able to guarantee efficiency and safety. Carpigiani original spare parts are guaranteed for 1 year.



Carpi Care kit



6

MONTHS

Periodically ask your dealer **Carpi Care kit and Carpi Clean kit.** Dedicated kit of gaskets and brushes to keep each machine hygienic & clean.

Carpi Clean kit

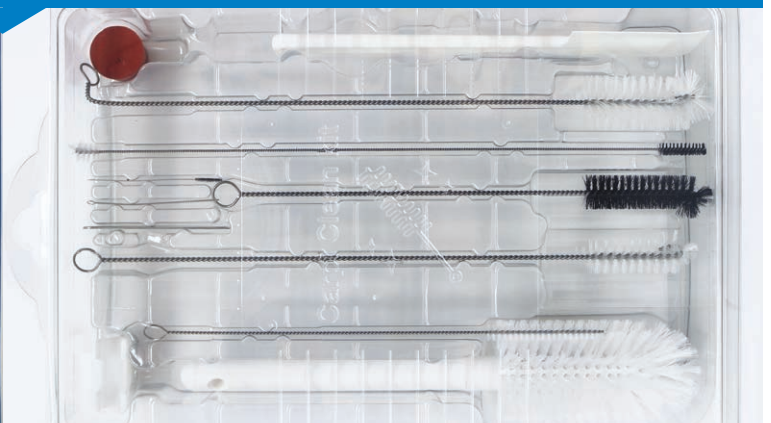

WHAT WE OFFER

Specialized technicians. Carpigiani technicians are professionals who are always up-to-date thanks to solid and constant training courses that guarantee high levels of competence for any inspection, maintenance, cleaning and repair intervention.



Preventive maintenance. Thanks to periodic checks, entrusted to certified technicians, the machine can always work in optimal conditions, preventing any downtime.

Extended Warranty. Operate machine in complete tranquility, thanks to the Carpigiani extended warranty. In case of needs, in fact, Carpigiani technicians are able to restore machine operation with original spare parts.



Scheduled Cleaning. Possibility of entrusting the periodic cleaning of the machine to expert technicians.



Teorema. Teorema Remote Control and diagnosis system for remote monitoring of machine operation. The customer can access the machine via computer, tablet or mobile device to remotely monitor operations. Teorema also facilitates the assistance service: Carpigiani technicians are alerted on the configuration parameters as if they were operating directly on the machine.



technical data - dimensions

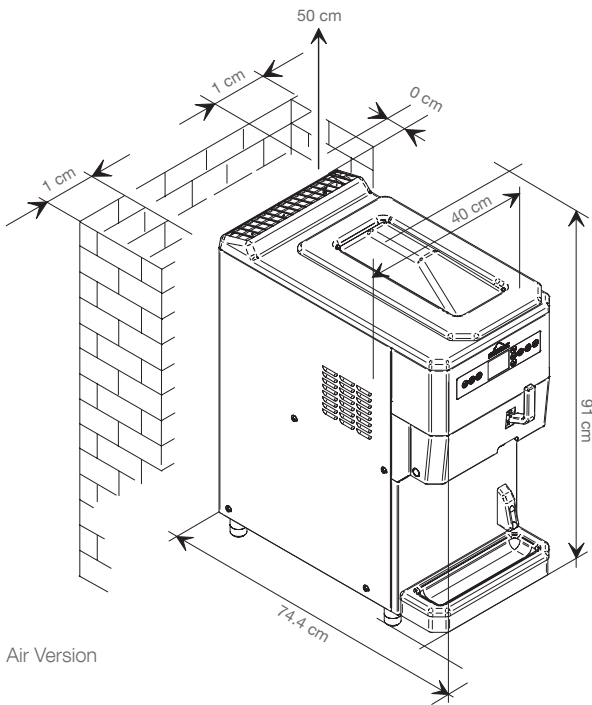

Air Version

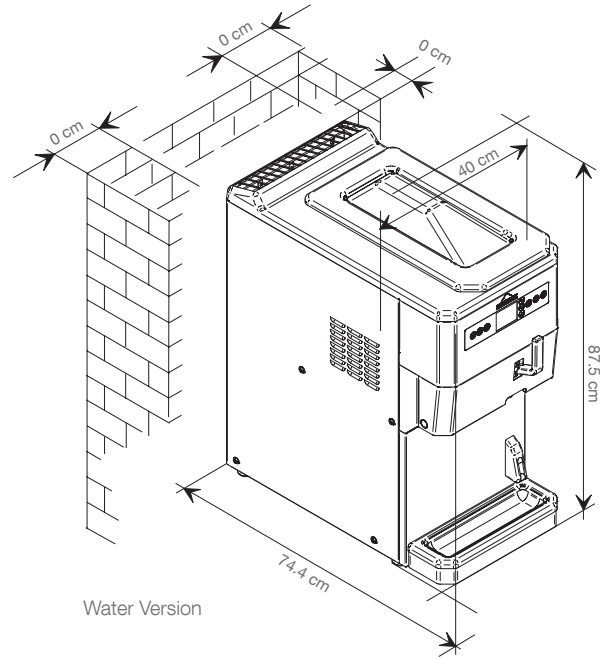

Water Version

XLV 1 Counter

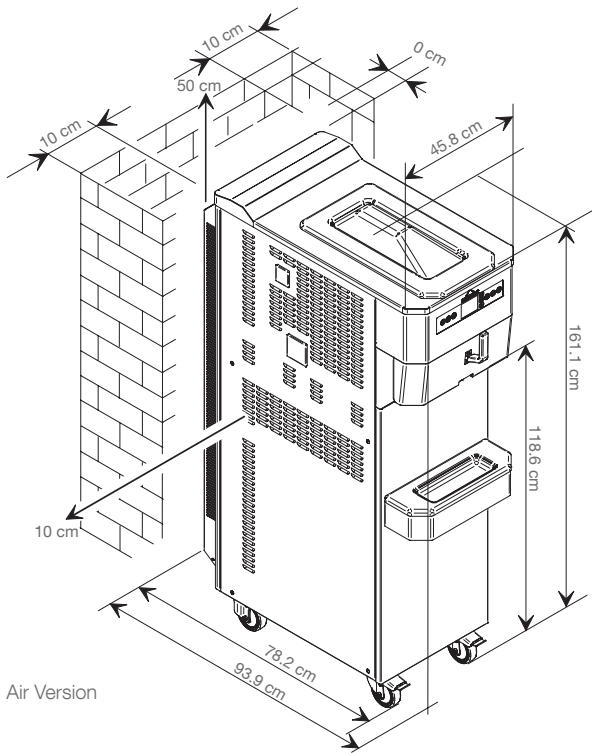

Air Version

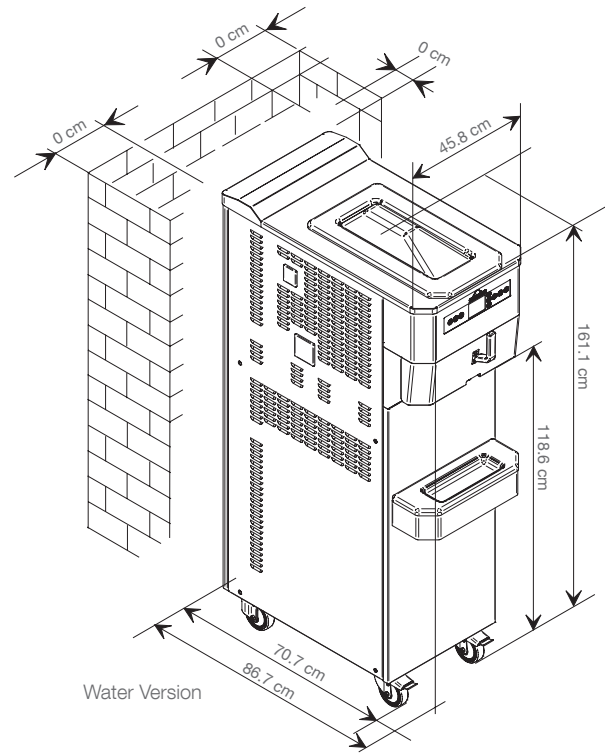

Water Version

XLV 1 STEEL

technical data - dimensions

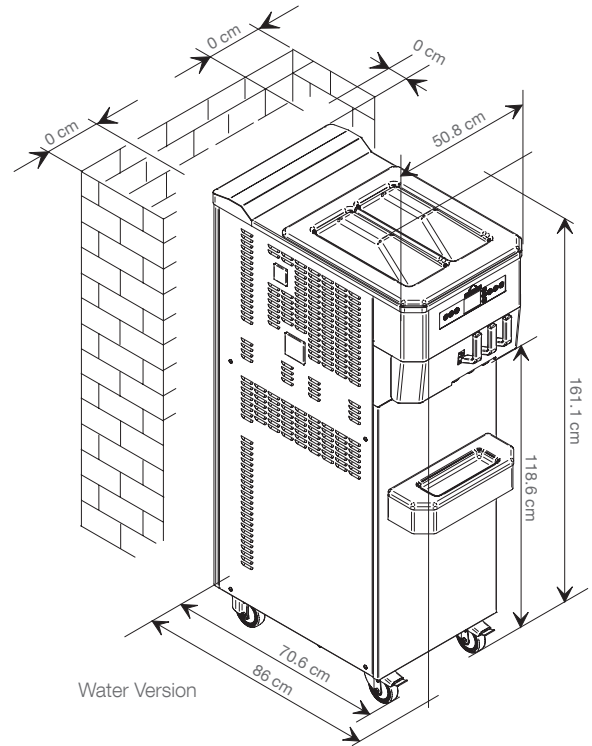
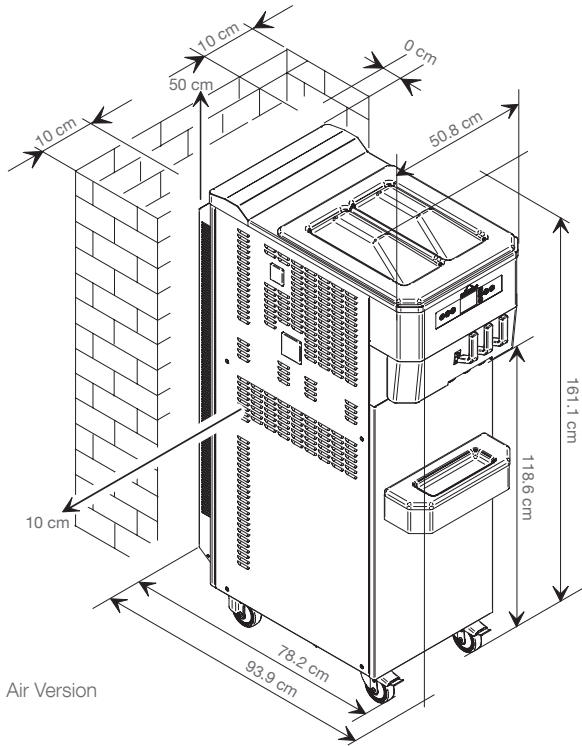

XVL 3 STEEL

XVL 1 - XVL 3

Steel



	Flavours	Mix Delivery System	Hourly production (75gr portions)		Tank Capacity lt	Cylinder Capacity lt	Rated Power Input kW	Fuse Size A	Power Supply Volt Hz Ph	Cooling System	Refrigerant	Net Weight kg
			POM	2E-RSI								
XVL 1 Counter P SP	1	Pump	-	310*	13	1.75	2.4	10	400/50/3**	Air, water optional	R452***	170
XVL 1 Counter G SP		Gravity	265*	-								160
XVL 1 Steel P	1	Pump	465*	510*	13	1.75	2.5	10	400/50/3**	Air, water optional	R452***	230
XVL 1 Steel G		Gravity	440*	-			2.4					225
XVL 3 Steel P	2+1	Pump	630*	695*	13+13	1.75	5.0	16	400/50/3**	Air, water optional	R452***	310
XVL 3 Steel G		Gravity	600*	-			4.8					300

*production capacity depends on the mix used and the room temperature **other voltages and cycles available upon request
 ***alternative solutions available.

XVL are produced by Carpigiani with UNI EN ISO 9001 Certified Quality System.

All specifications mentioned must be considered approximate; Carpigiani reserves the right to modify, without notice, all parts deemed necessary.



Via Emilia, 45 - 40011 Anzola dell'Emilia - BOLOGNA, Italy - T. +39 051 6505111 - info@carpigiani.it

an Ali Group Company



the spirit of excellence