

PLAN VIEW

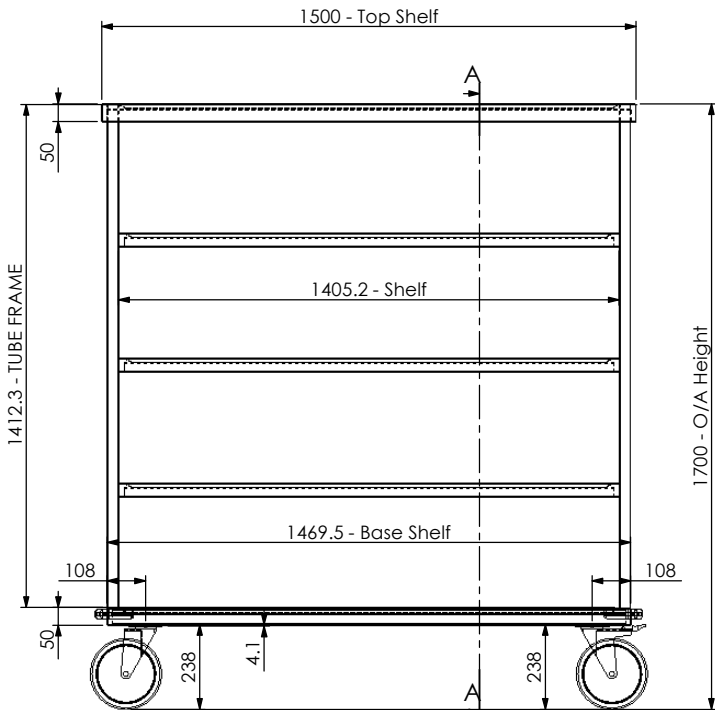

FRONT ELEVATION

off REQUIRED

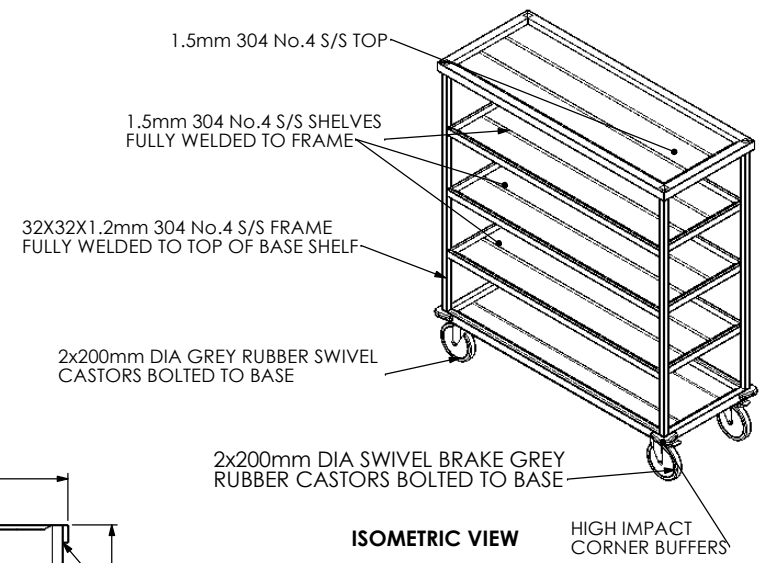

ISOMETRIC VIEW

150x25x1.5mm 304 No.4 S/S SUPPORT CHANNELS, DOUBLE SIDED TAPE TO SHELVES & ENDS FULLY WELDED TO FASCIA

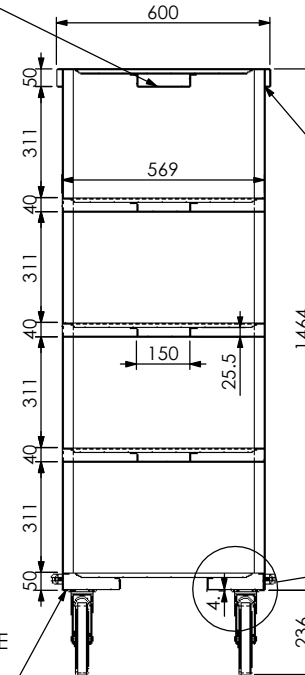

SECTION A-A

160x35x2.0mm 304 No.4 S/S SUPPORT CHANNELS, DOUBLE SIDED TO BASE & ENDS FULLY WELDED TO FASCIA

Tube frame fully welded to base ground & polished

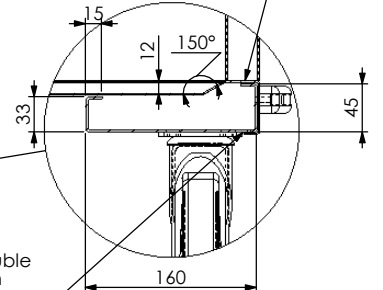

DETAIL AB SCALE 1 : 5

Castor supports double sided taped & stitch welded to base turn under

Tube frame fully welded to top shelf turn under mop polished

Job Id/WO No:
Item No:
Project Name:
Client Name:



www.stoddart.com.au

DRAWN: A Berrios				SIGNATURE: [Signature]		DATE: 13/07/2011		UNLESS OTHERWISE SPECIFIED: DIMENSIONS ARE IN MILLIMETERS	
APPROVED: [Signature]				MATERIAL:		THICKNESS:		FINISH:	
Weight:				Surface Area:		DWG No: CT-QMT-S5-1500-600-1700-d01 A1		Dwg. Issue: 1	
DO NOT SCALE DRAWING This drawing remains the property of Tom Stoddart Pty Ltd ABN 16 009 690 251 & cannot be reproduced without prior permission. A3 Sheet 1 of 11									

REV/VER.	REVISED BY	DATE	REVISION DESCRIPTION	STATUS
A1	A Berrios	13/02/2017	Name update to match M1. No sheetmetal changes.	