

Cutting Method		
Manual	Laser	TruPunch

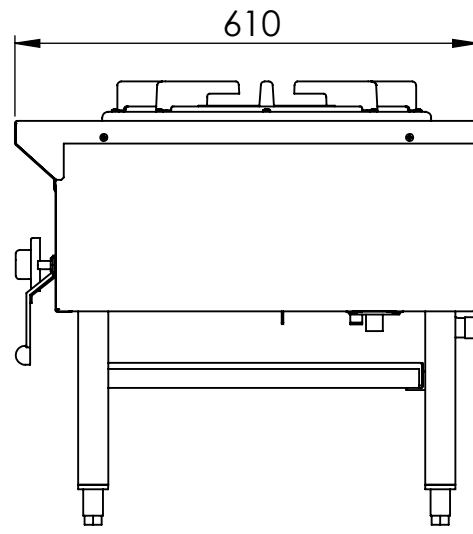

UNLESS OTHERWISE SPECIFIED:
 1. DIMENSIONS ARE IN MILLIMETERS
 2. TOLERANCES:
 LINEAR: +/- 1mm
 ANGULAR: +/- 0.30°
 3. BEND RADII 2.5mm. ALL BENDS AT 90°.

SURFACE FINISH:
 1. NATURAL.
 2. NO BLEMISHES OR SCRATCHES ON BASE METAL.
 3. REMOVE ALL BURRS AND SHARP EDGES.

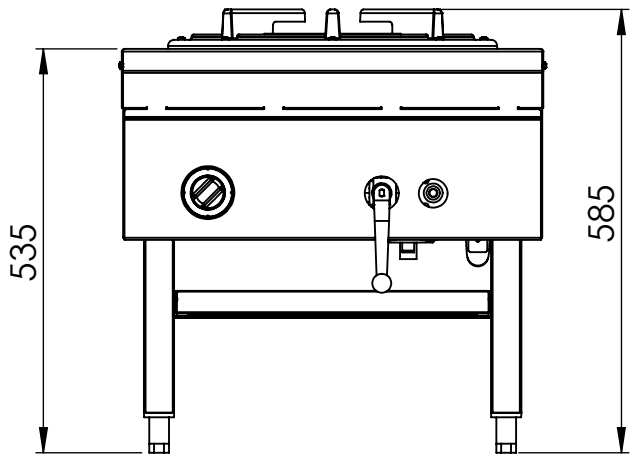
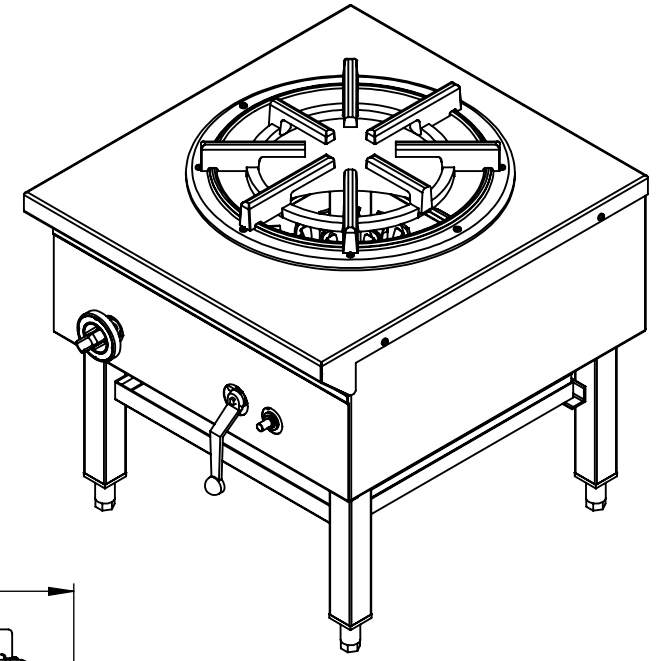
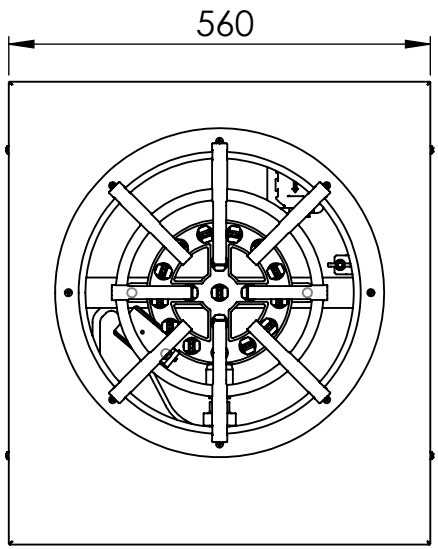
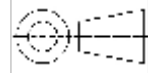

DO NOT SCALE DRAWING

REVISION



B & S Commercial Kitchens
 57 Plateau Road, Reservoir/Victoria, 3073
 Tel.: (03) 9469 4754 / Fax: 9469 4504

	NAME	SIGNATURE	DATE		
DRAWN	S.K		7/03/2018		
UPDTD				THICKNESS (mm):	
APPVD				MATERIAL:	
MFG					
Q.A					
				WEIGHT: -	

TITLE:	CSPK Ass'y	
DWG NO.	CSP	A4
SCALE: 1:10	SHEET 1 OF 1	