

STGHT12-SD



PRODUCT FEATURES

- Deck forced heating
- Single glazed
- Sliding rear doors
- Solid front or sliding front doors
- Three adjustable shelves - flat or angled
- Ticket strips on shelves and base
- Under shelf and canopy LED lights

Maximum shelf load weight 15kg spread evenly

STGHT12

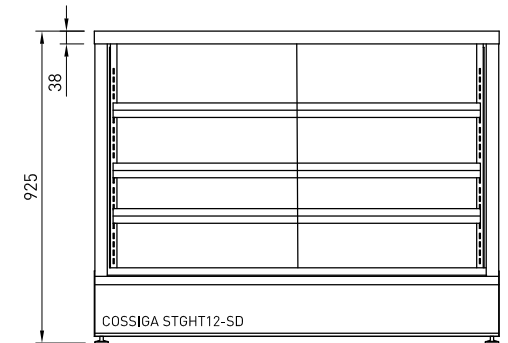
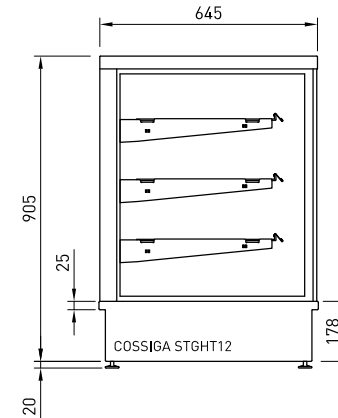
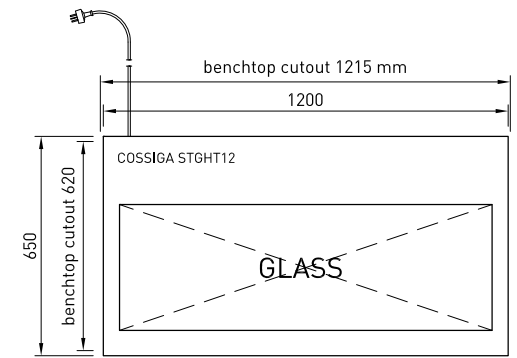

Heated 68°C-78°C

CABINET DIMENSIONS & SPECIFICATIONS

Prior to installation see, installation guidelines, ventilation requirements and drainage options documents

MODEL	CABINET				CUT OUTS	SHELVING		BASE TRAY	TOTAL FOOD	DISPLAY M ²	INTERNAL VOLUME M ³	POWER		CONNECTION ELECTRICAL POWER CORD 2200MM		VOLTAGE	PACKED FOR SHIPPING			
	LENGTH [MM]	DEPTH [MM]	HEIGHT [MM]	WEIGHT [KG]		NO.	SIZE W X D					SIZE W X D	KW 230V	AMPS	NZ/AUS		UK	LENGTH [MM]	DEPTH [MM]	HEIGHT [MM]
STGHT12-SD STGHT12	1200	650	925	126	1215x620	3+BASE	1090 x 440	1140x 415	121	1.75	0.46	2.21	9.6	15 AMP 3 PIN PLUG	15 AMP 3 PIN PLUG	220~240V	1300	730	1100	133