



COMBI VEGETABLE PREP-CUTTER CK-302 230/50-60/1

2 in 1: veg prep machine (450 kg/h) with 8 lt. / 8 1/2 qt. cutter bowl



P/N 1050345



SALES DESCRIPTION

It consists of a variable speed motor block with a regular hopper and a 8 litre / 8 1/2 qt. food processor bowl complete with a hub with serrated blades.

FEATURES AND BENEFITS

As vegetable preparation machine, its ergonomic design allows to cut the product in just one movement. As cutter, is equipped with a 8-litre / 8 1/2 qt. bowl with a scraper and hub with serrated blades.

Discs are not included*.

- ✓ User-friendly, waterproof led-lit control panel.
- ✓ Hopper, lid and bowl easily detachable for interchanging or cleaning.

AS VEGETABLE PREPARATION MACHINE:

- ✓ Machine and discs specially designed to obtain the perfect cut.
- ✓ Adjustable speed (5 positions).
- ✓ Ergonomic design: large production with only one arm motion.
- ✓ Lateral shootout: allows operation in reduced spaces and directs the product avoiding spray.

AS FOOD PROCESSOR

- ✓ Adjustable speed (10 positions), programmable by time and pulse switch.
- ✓ 5 qt. stainless steel food processor bowl.
- ✓ Polycarbonate lid complete with scraper that allows consistent and homogeneous mixing and avoids product overheating.
- ✓ Optional flat blade set for raw meat and fibrous products.
- ✓ Optional perforated blade set specially designed to beat and mix.

INCLUDES

- ✓ Variable speed motor block.
- ✓ Regular hopper.
- ✓ Food processor bowl complete with hub with serrated blades.

ACCESSORIES

- Long vegetable attachment. des.
- Discs, grids, disc holder device.
- Stand-trolley.
- Hub with flat blades.
- Hub with perforated blades.



sammic | www.sammic.com
Food Service Equipment Manufacturer

Polígono Basarte, 1. phone +34 943 15 72 36
20720 Azkoitia, Spain sales@sammic.com



Project	Date
Item	Qty
Approved	

DYNAMIC PREPARATION
FOOD PROCESSOR / VEG PREP COMBI MACHINES

product sheet
updated 22/03/2019



COMBI VEGETABLE PREP-CUTTER CK-302 230/50-60/1

2 in 1: veg prep machine (450 kg/h) with 8 lt. / 8 1/2 qt. cutter bowl



P/N 1050345

SPECIFICATIONS

Total loading: 1500 W

Electrical supply: 230 V / 50-60 Hz / 1 ~
(-- A)

Plug: EU

As vegetable preparation machine

Hourly production: 150 Kg - 450 Kg

Inlet opening: 136 cm²

Disc diameter: 205 mm

Speeds as veg. slicer (positions): 5 (365 rpm - 1000 rpm)

External dimensions (WxDxH): 389 mm x 412 mm x 565 mm

Net weight: 28 Kg

As cutter

Bowl capacity: 8 l

Speeds as cutter (positions): 10 (365 rpm - 3000 rpm)

External dimensions (WxDxH): 283 mm x 390 mm x 558 mm

Net weight (Cutter): 24 Kg.

Crated dimensions

35 x 60 x 40 mm

Gross weight: 36 Kg.

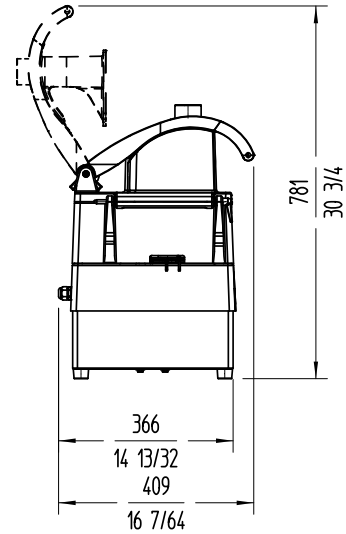
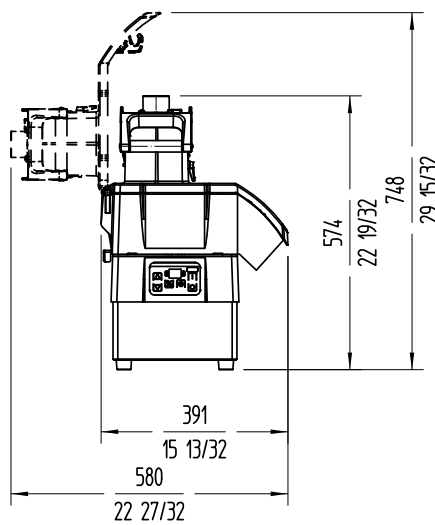
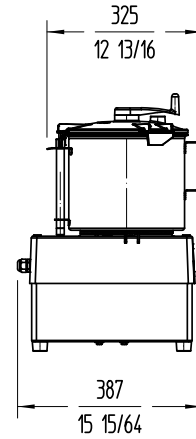
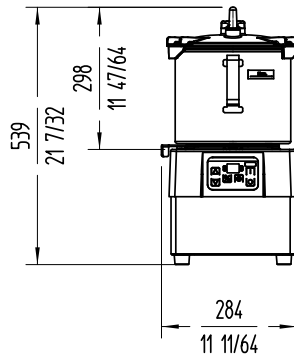

DYNAMIC PREPARATION
FOOD PROCESSOR / VEG PREP COMBI MACHINES

sammic | www.sammic.com
Food Service Equipment Manufacturer

Polígono Basarte, 1. phone +34 943 15 72 36
20720 Azkoitia, Spain sales@sammic.com



Project	Date
Item	Qty
Approved	

product sheet
updated 22/03/2019