



### Product Advantages:

- Heating by integrated electric steam production.
- Double jacket steam heating by integrated immersed high performance electric heaters with thermostat.
- Electronic regulation of the water level into the double skin
- Water inlet.
- Electric tilting.
- Watermeter on hot or cold water network Mixing arm inclined at 15° with engine power fixed on top. Equipped with teflon scrappers fixed on a s/s axis.
- Control panel: Siemens with colour 7 inches touch screen. Setting of 100 recipes Possibility to transfer the production data on a USB key.

### Options:

- Cooling device: Cooled water inlet in the exchanger, evacuation of overflow of water, pipe at the top of the tank to be connected to the compressed air network in order to reduce the pulling time, clean up of the exchanger at the end of the cycle
- Drainrack: Perforation diameter 8 mm

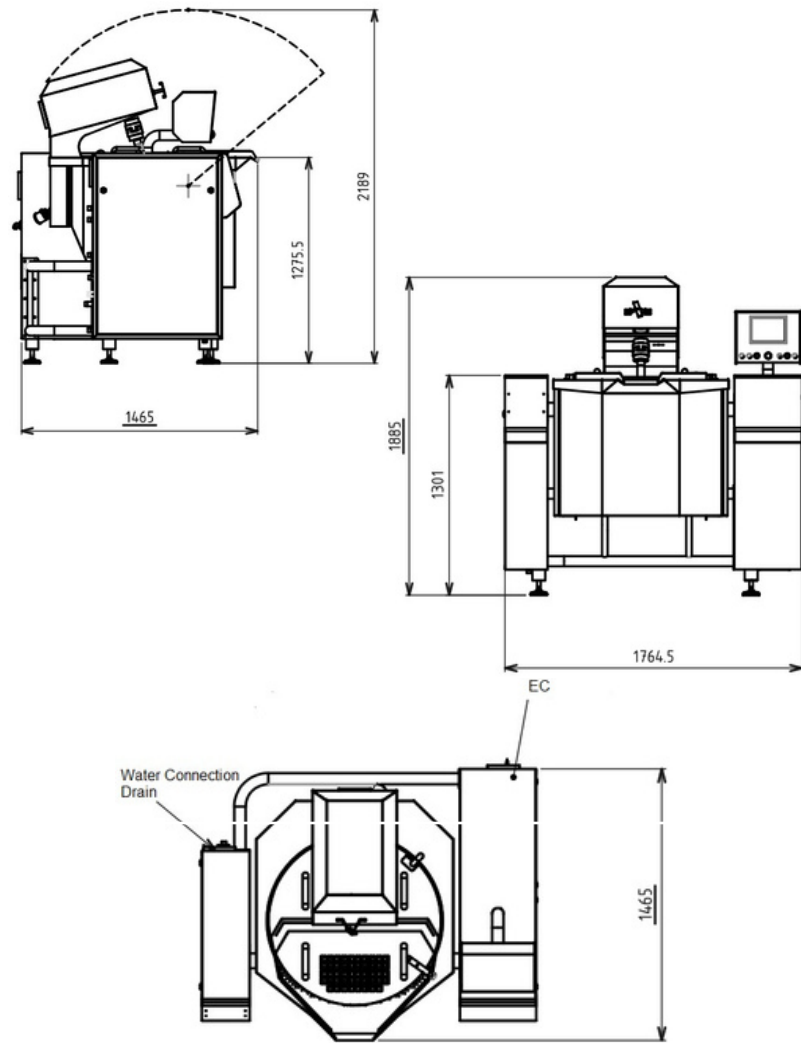

### Technical Data:

External dimensions (WxHxD)	1780 x 1900 x 1470 mm
Water network pressure	2/3 bar (max)
Maximum pressure	0.5 bar
Maximum steam temperature	105 °C
Capacity	300 L
Connected load (kW)	35
Voltage (V)	415 3 phase AC
Frequency (Hz)	50
Recommended fuses (A)	3 x 60
Space between tank and pillars	70 mm (easy cleaning)

