

INDUSTRY
KITCHENS

www.industrykitchens.com.au 1800 611 058

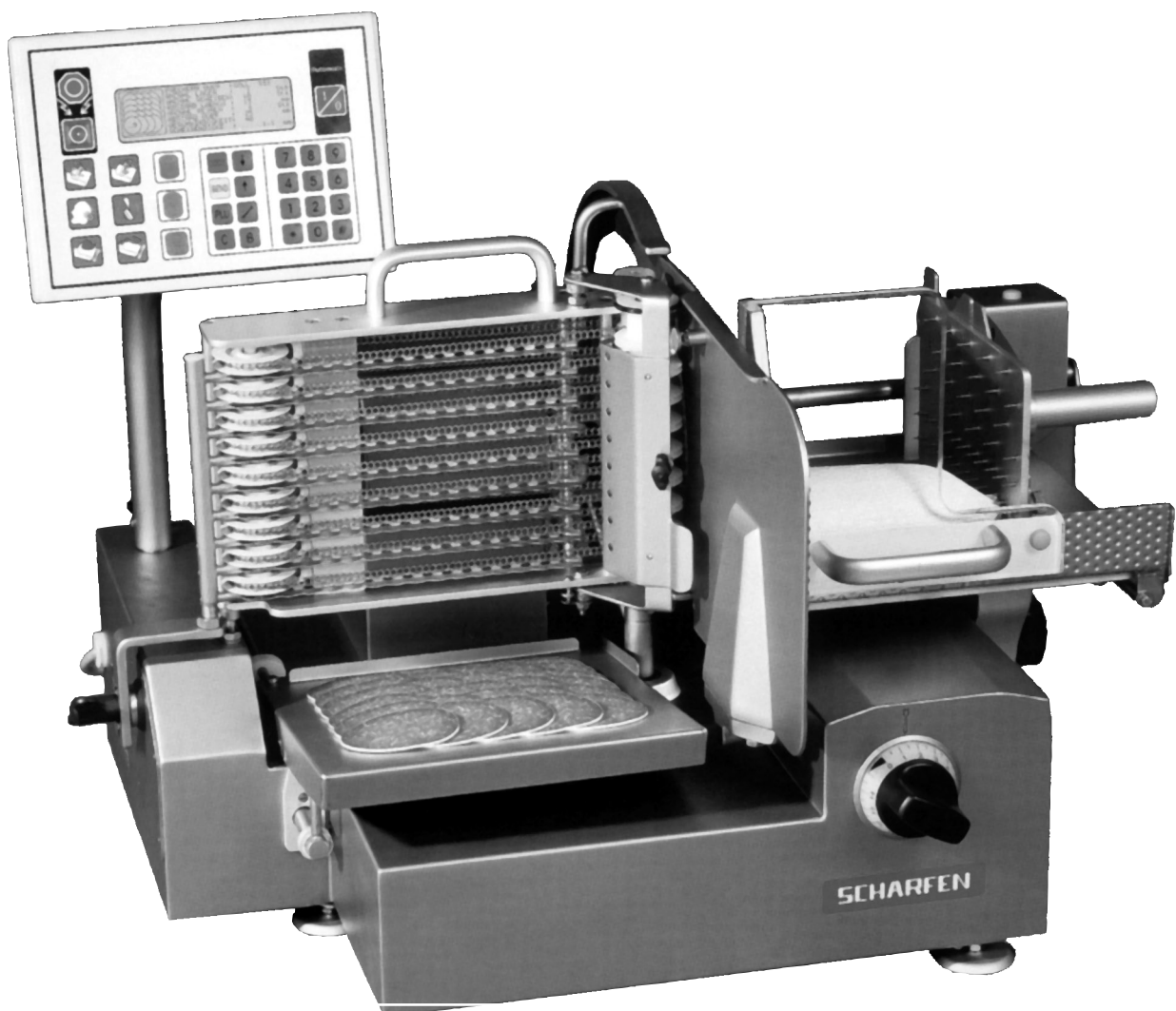

The VA4000 programmable fully automatic food slicer is fast, clean and efficient, ideal for large kitchens, delicatessens and processed meat works.



Model

VA4000

Programmable Automatic
Food Slicer



Heavy Duty Continuous; Gear-driven/Chain-driven; Fully-automatic

Model VA4000

Programmable Automatic Food Slicer

The Model VA4000 food slicer is built for high volumes and hard work. It is fully automatic, fully programmable, electronically controlled, fast, clean and efficient.

Besides slicing food products, it collects the slices on a product receiving tray in either vertical stacks, shingled groups, or a constant shingled form.

The number of slices to each stack or group can be set at the control panel by the operator. Maximum stack heights or a constant shingle can be easily and simply programmed.

Depending on the product width, two or more pieces may be loaded on the meat table for one slice operation, increasing productivity.

- Manufactured in stainless steel;
- Fully automatic slicing and stacking operations;
- Combined End Piece Holder and Meat Comb to minimise slicing waste;
- Programmable slicing and shingling speeds;
- Machine can be programmed for unattended operation;
- Removable sharpening device;
- Gear driven blade and fan-cooled motor;
- Chain driven carriage;
- Separate push-button ON, OFF and START switches for safety;
- Carriage can be tilted for easy cleaning;
- CE approved.



User-friendly programming interface.

SPECIFICATIONS

Blade (mm)	330
Overall Dimensions (mm)	
Width	853
Depth	620
Height	660
Single (240V) phase or three (415V) phase motor power requirement (W)	600
Net weight (kg)	80
Slice Capacity	
Height (mm)	195
Length (mm)	255
Max. Slice thickness (mm)	10

Speed of carriage is infinitely variable, about 25-55 strokes per minute.

Stacking

1-4 stacks per slicing procedure adjustable, maximum height stack 80mm.

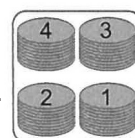

Shingling Down

Shingling distance down up to 30mm (infinitely variable), per slicing procedure 1-2 shingled portions side by side, and up to 9 layers on top of the others.

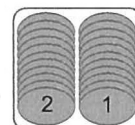

Shingling Cross

Shingling distance down and cross up to 30mm (infinitely variable), per slicing procedure 1-9 shingled portions side by side and up to 9 layers on top of the other.

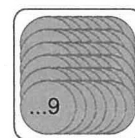

Circle Shingling

Circle shingling with a diameter of up to 230mm and up to 9 layers on top of the other.

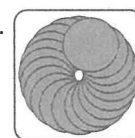

99 Programmable Slicing Programmes

The VA4000 has 99 programmable slicing settings, each programme can be customised with the name of article, speed of the carriage, slice thickness and all parameters for stacking, shingling down and cross or circle shingling. Each programme can be easily activated by entering the PLU-number with max. 3 digits between 001 and 999.

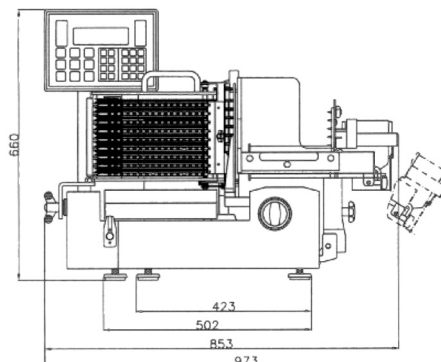
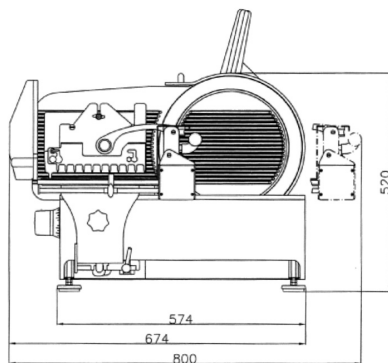

Brice Australia Pty. Ltd. ABN 71 413 589 669
100% Australian owned and operated
Copyright ©2017 Brice Australia Pty. Ltd.

BRICE HEAD OFFICE:
11 Holloway Drive,
Bayswater, Victoria 3153 Australia

Ph: 1300 664 880
www.briceaust.com.au
email: info@briceaust.com.au