

The OMATS Series Minchers are powerful, heavy-duty mincers ideal for large restaurants, catering kitchens, butchers and pizzerias.



OMATS22

- **Reversible drive motor**
Powerful and hard-working.
- **Comprehensive electrical and mechanical safety features**
- **Easy cleaning**
Machine disassembles quickly for effective cleaning;
Stainless steel and anodised aluminium construction.
- **CE approved**

Model OMATS 8,12,22 Heavy Duty Mincers

CE Approved

The OMATS Series meat mincers – the TS8, TS12 and TS22 – offers quiet and efficient mincing.

In the OMATS Series range there is a mincer to suit every application.

All the OMATS Series feature:

- Stainless steel and anodised aluminium construction to resist corrosion, and the cutting group, inlet throat and barrel are made from stainless steel;
- Drive reduction gears run in an oil bath to maintain maximum lubrication;
- Reversing switch to clear blockages;
- CE approved;
- Available in 1-phase or 3-phase power;
- Pusher included;
- Receiving tray included (TS12, 22)

SPECIFICATIONS

	TS8	TS12	TS22
Barrel dia. (mm)	62	70	82
Throughput (up to kg. p/h)	50	150	250
Power (w)	500	750	1100
Weight (kg)	13	22	32
Dimensions (mm)	TS8	TS12	TS22
Width	170	220	230
Depth	210	490	670
Height	380	430	470

TS8



TS12

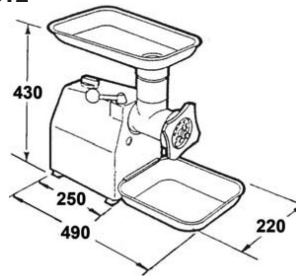

TS22

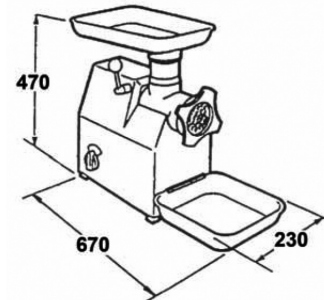

The compact TS8, is ideal for small butcher shops and delicatessens.



The volume seller of the family, the TS12, is ideal for butcher shops and smaller restaurants



The TS22 works hard in larger butcher shops and restaurants.



Brice Australia Pty. Ltd. ABN 71 413 589 669
100% Australian owned and operated
Copyright ©2018 Brice Australia Pty. Ltd.

BRICE HEAD OFFICE:
11 Holloway Drive,
Bayswater, Victoria 3153 Australia

Ph: 1300 664 880
www.briceaust.com.au
email: info@briceaust.com.au