

INDUSTRY  
KITCHENS

[www.industrykitchens.com.au](http://www.industrykitchens.com.au) 1800 611 058



The BRO Series of manual, hand-operated sausage fillers are ideal for small production runs. Simple to use and easy to clean, they are the perfect solution in any small butcher shop or delicatessen.



Light Duty; Manual Operation

Model  
**BRO Series**  
Manual Sausage Filler

# Model BRO Series Manual Sausage Filler

- **Range of sizes**  
Available in 5kg (5 Litre) and 8 kg (6.8 Litre) capacities.
- **Built tough for hard work**  
Stainless steel construction, with cast iron gear box and plastic meat piston.
- **Variable manual speed**  
Slow and fast filling operation (forward and reverse movements).
- **Easy operation**  
Simple to use, clean and maintain.
- **Comes with four nozzles**  
15, 23, 28 and 38mm.

## SPECIFICATIONS

	5kg	8kg
Net Weight kg	10.5	12
Litre Capacity	5	6.8
<b>Dimensions (mm)</b>		
Width	335	335
Depth	575	670
Height	205	205

## COMPONENTS

- 1 Aluminium Flange
- 2 Small Gear
- 3 Crank Handle
- 4 Casing
- 5 Ring Nut
- 6 Nozzles (a=38mm, b=28mm, c=23mm, d=15mm)
- 7 Stainless Steel Tube
- 8 Large Gear
- 9 Buffer
- 10 See-through Gasket
- 11 Rack
- 12 Forward/Reverse Motion Pin (Slow movement)
- 13 Forward/Reverse Motion Pin (Fast movement)

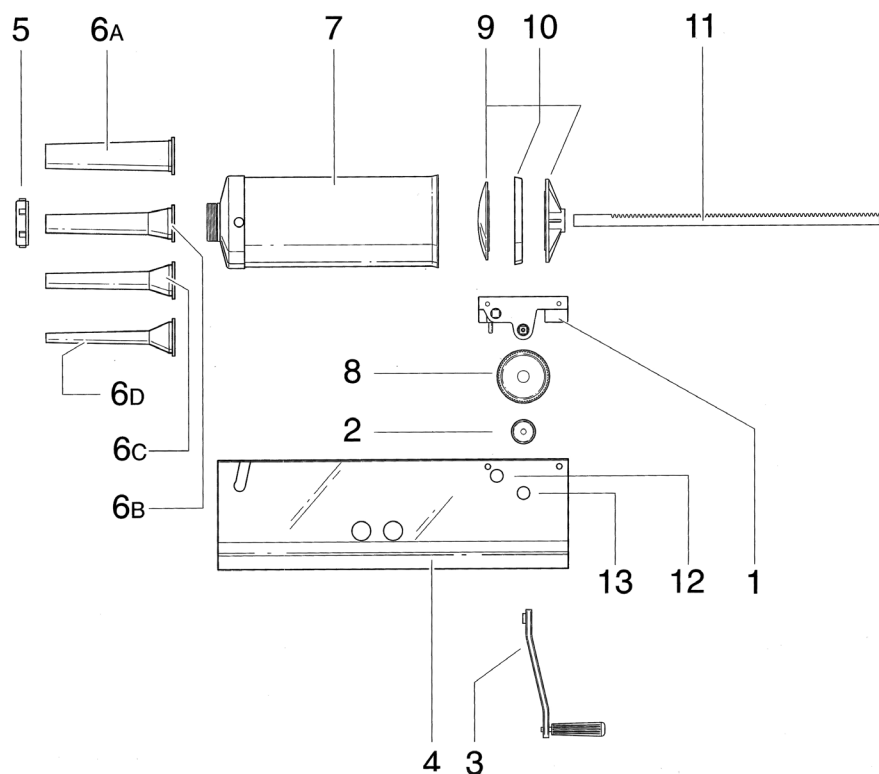

### Before using the BRO Manual Sausage Filler

1. Ensure that the Bro Manual Sausage Filler is positioned on a solid flat surface at a height that allows the operator to use without undue strain.
2. Ensure that a suitable container is positioned under the nozzle to collect finished product.

### Operating instructions

1. Unscrew the ring nut (5) on the end of the stainless steel tube (7).

2. Select nozzle size (6) and secure to the stainless steel tube (7) by re-attaching the ring nut (5).
3. Turn the crank handle (3) in a clockwise direction to fully extend the rack (11) which releases the stainless steel tube (7).
4. Fill stainless steel tube (7) with food product and return tube to main casing (4).
5. Select motion pin (12 or 13) and turn crank handle (3) in an anti-clockwise direction.

### Cleaning instructions

At the end of usage, extend the rack (11) to release the stainless steel tube (7) unscrew the ring nut (5) and remove the nozzle (6). Carefully lift the stainless steel tube from the main casing (4) and wash all components that have in contact with the food product in warm soapy water. Thoroughly dry all components before re-using.



Brice Australia Pty. Ltd. ABN 71 413 589 669  
100% Australian owned and operated  
Copyright ©2020 Brice Australia Pty. Ltd.

**BRICE HEAD OFFICE:**  
11 Holloway Drive,  
Bayswater, Victoria 3153 Australia

**Ph: 1300 664 880**  
[www.briceaust.com.au](http://www.briceaust.com.au)  
email: [info@briceaust.com.au](mailto:info@briceaust.com.au)