

INDUSTRY
KITCHENS

www.industrykitchens.com.au 1800 611 058



The CELPRO250 & 300XL manual slicers are light duty and belt-driven. They are ideal for caterers, restaurants, small/medium kitchens and delicatessens.



Model

CELPRO250/300XL

Belt Driven Slicers



Light Duty; Belt-Driven; Manual Operation

Model CELPRO Belt Driven Slicers

The CELPRO250 and 300XL belt-driven food slicers have been designed for precision slicing. Perfect for small cafés, restaurants and convenience stores.

Features:

- Removable carriage for easy cleaning.
- Micrometric adjusting knob allows for cutting of slices up to 12mm (CELPRO250); 15mm (CELPRO300XL).
- Self contained inbuilt and shielded sharpening device.
- Forced ventilation to motor.
- Belt driven blade.
- Blade ring guard.
- Low voltage switching.
- Safety guard.
- Extended LSD handle.
- Mechanical safety interlock to prevent the blade being exposed when the carriage is removed for cleaning.



The built-in sharpener is simple and safe to operate.



Precision adjustment of slice thickness.

SPECIFICATIONS

	250	300XL
Dimensions (mm)		
Width	290	330
Depth	445	480
Height	350	420
Product Table (mm)	210x215	235x260
Blade (mm)	250	300
Power	180W	220W
240V single phase motor	50Hz	50Hz
Operating Temp Range	+5°C - +40°C	
Net weight (kg)	13.5	23
Max. Slice thickness (mm)	12	15
IP Rating	21	21

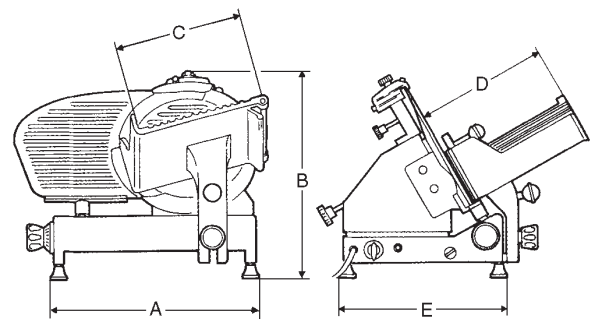

CELPRO250



CELPRO300XL



Brice Australia Pty. Ltd. ABN 71 413 589 669
100% Australian owned and operated
Copyright ©2023 Brice Australia Pty. Ltd.

BRICE HEAD OFFICE:
11 Holloway Drive, Bayswater,
Victoria 3153 Australia

Ph: 1300 664 880
www.briceaust.com.au
email: info@briceaust.com.au

