

INDUSTRY
KITCHENS

www.industrykitchens.com.au 1800 611 058



The Chef Food Slicer & Grater is perfect for moderate to high-volume use in larger restaurants, supermarkets and delicatessens.



Model
CHEF300
Food Slicer & Grater



Medium Duty; Manual Operation; CE Approved

Model CHEF300

Food Slicer & Grater

CE Approved

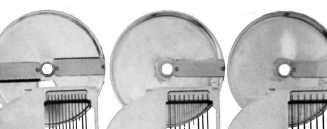
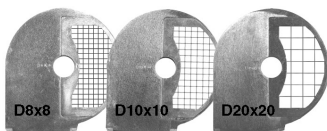
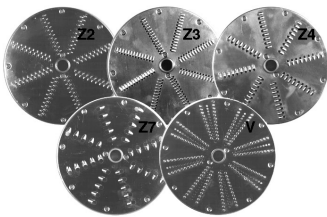
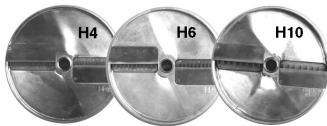
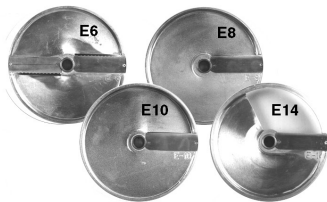
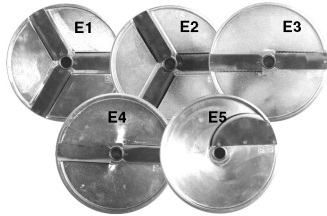

The Chef Food Slicer & Grater has been designed for moderate to high-volume use in larger restaurants, supermarkets and delicatessens.

Convenience features include, fast blade change and dual inlet chutes, which make for fast and efficient slicing of any kind of fruit or vegetable in the busiest environment.

- Manufactured in anodised aluminium and stainless steel to resist the corrosive effects of salts and acids;
- Constructed for easy cleaning;
- Up to 60 different slicing and grating combinations;
- Safety interlock switches prevent operation if the machine is opened or the feeder handle is not closed;
- Forced ventilation to motor.

SLICING DISCS

E1, E2, E3, E4, E6, E8, E10 & E14: For slices from 1 to 14 mm. Potato chips, potato, turnip, cabbage, cucumber, carrot, mushroom, onion, marrow, aubergine, fennel, artichoke.

E5, E15 & E25: For slices from 1 to 5 mm. Hard salami, mushroom, tomato, lemon, orange, apple, banana, pineapple, grapefruit, etc.

E30, E40, E60, E80, E100, & E140: For fruit and vegetable wavy slices from 1 to 14 mm.

VE3, VE4, VE, 6 & VE 8: Use to slice complete vegetables. White cabbage, red cabbage, etc.

SPECIFICATIONS

Model	300
Blade (mm)	205
Motor	240V, 50Hz, 380W,
Net weight (kg)	18.5
Dimensions (mm)	
Width (B)	240
Depth (C)	570
Height (A)	470

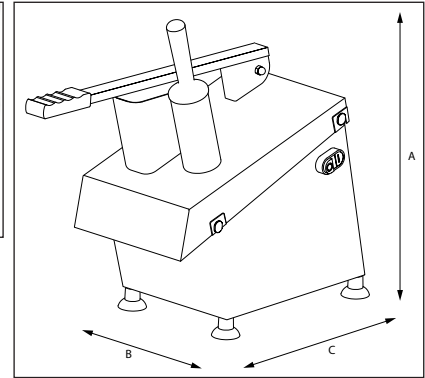

MATCH-LIKE CUTTING DISCS

H2.5, H4, H6, H8 & H10: Celery, marrow, beetroot, carrot, potato, cabbage, etc.

SHREDDING OR GRATING DISCS

Z2, Z3, Z4 & Z7: Carrot, celery, potato, apple, turnip, beetroot, red cabbage, cheese, chocolate, etc.

V: Cheese, dry bread, nuts, chocolate, etc.

CUBIC CUTTING DISCS

D8x8, D10x10, D12x12, D16x16 & D20x20: Used in combination with any of the E series discs produces three different sizes of cubes or strips for use in soups, fruit salads, etc.

NOTE: Use of dicing discs is not recommended for hard vegetables, including but not limited to pumpkin, turnip, swede.

CHIPPING GRID DISCS

B6, B8 & B10: Use in combination with E series discs to obtain matchlike chips. Use with the E0 series discs to produce chips with wavy sides.



Brice Australia Pty. Ltd. ABN 71 413 589 669
100% Australian owned and operated
Copyright ©2024 Brice Australia Pty. Ltd.

BRICE HEAD OFFICE:
11 Holloway Drive, Bayswater,
Victoria 3153 Australia

Ph: 1300 664 880
www.briceaust.com.au
email: info@briceaust.com.au

