

The Model 300IX gravity-feed manual slicer is a heavy duty machine designed for slicing a range of meat products. An ideal slicer for restaurants, caterers, medium/large kitchens and delicatessens.

- **Belt Driven**
Powerful and hard-working.
- **Comprehensive electrical and mechanical safety features**
- **Built in sharpener**
Easy operation means great cuts every time
- **Easy cleaning**
Machine disassembles quickly for effective cleaning
- **CE approved**



Model
300IX
Gravity-feed Slicer

Model 300IX Gravity-feed Slicer

CE Approved

The heavy duty Model 300IX Gravity-feed slicer has been designed to handle meats of all kinds.

The big receiving plate permits great freedom in slice accumulation. Along with the model's other features, this makes the machine one of the most functional on the market.

- Manufactured in stainless steel and anodised aluminium to resist the corrosive effects of salts and acids;
- Constructed for easy cleaning;
- Micrometric adjusting knob allows for cutting of slices up to 16mm
- Removable built-in dual action sharpener ensures a long lasting razor sharp blade and ease of cleaning;
- Forced ventilation to motor;
- Belt driven blade uses super-quiet Poly-V drive belt;
- Full-shield blade ring guard for operator safety;
- Mechanical safety interlocks to prevent the blade being exposed when the carriage is removed for cleaning;
- CE Approved.



The built-in sharpener is simple and safe to operate.



Precision slicing with the micrometric slice thickness knob.



Simple, low-voltage switches turn the 300IX on and off.

SPECIFICATIONS

Blade (mm)	300
Motor	240V single phase, 50Hz, 242W
Dimensions WxDxH (mm)	510x580x510
Slice Capacity	
Rectangular (mm)	255x220
Circular/Diameter (mm)	220
Max. Slice thickness (mm)	16
Net weight (kg)	26.5

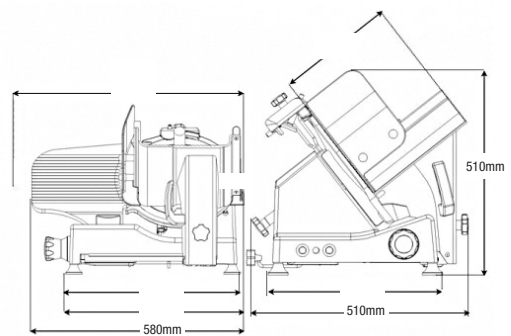

Brice Australia Pty. Ltd. ABN 71 413 589 669
100% Australian owned and operated
Copyright ©2017 Brice Australia Pty. Ltd.

BRICE HEAD OFFICE:
11 Holloway Drive,
Bayswater, Victoria 3153 Australia

Ph: 1300 664 880
www.briceaust.com.au
email: info@briceaust.com.au