

## GAS GRIDDLE 900mm

GP516-B, GP516-CB, GP516-LS, GP516-RB

- Heavy-duty thermostatic gas griddle
- 20mm thick griddle plate
- Ribbed plate options
- Mirror chromed plate options
- Top weld sealed plates
- 80MJ thermostatic burner system
- Separate left and right heat zones
- 3 models of base unit
- 1 model of refrigerated base with two GN 1/1 drawers
- Rear rollers
- Stainless steel exterior
- Easy clean
- Easy service
- Fully modular



GP516-LS

### Overall Construction

#### Griddle

- 20mm thick machined top plates standard
- Optional ribbed plate sections
- Optional mirror finish hard chrome plates
- 2.5mm thick 304 stainless steel splash guards sides and rear
- 2.0mm thick grease channel
- Two 40MJ 3 bar even heat burners with dual thermostatic controls
- Full pilot and flame failure protection with piezo ignition
- Welded hob surround with 1.5mm 304 stainless steel bull nose
- Side panels 1.2mm 304 stainless steel
- Splashback 1.2mm 304 stainless steel
- Vitreous enamelled control panel
- Stainless steel grease drawer
- Overlapping finish at front and rear of plate for easy clean

#### Bench mount (supplied as -B model)

- Four 63mm dia. heavy-duty 1.2mm 304 stainless steel bench legs with adjustable feet.
- Adjustable height 80mm – 105mm

#### Cabinet base (supplied as -CB model)

- Fully modular for match suite finish
- Double skin 0.9mm 304 stainless steel interior and exterior
- Optional GN 1/1 4 position racking kit (1 or 2 cabinet bays)
- Up to eight 65mm GN 1/1 capacity
- 63mm dia. heavy-duty 1.2mm 304 stainless steel legs with two adjustable feet at front and two rollers at rear

#### Leg Stand (supplied as -LS model)

- Fully modular for matched suite finish
- Framed top for connection to Griddle
- 63mm dia. heavy-duty 1.2mm 304 stainless steel legs with two adjustable feet at front and two rollers at rear
- Fully modular framed stand shelf with 0.9mm 304 stainless steel finish
- Suitable for rear or through shelf gas connection to Griddle
- Quick assembly design

### Refrigerated base (supplied as -RB model)

- Self contained suite matched modular base
- Ventilated system with R134a refrigerant
- -2° to +8°C temperature (Tropical Climate rated)
- Two GN 1/1 drawers
- 100mm deep pan capacity
- Heavy-duty European telescopic drawer guides
- Magnetic drawer gaskets (replaceable without tools)
- 50mm fully foamed CFC free insulation
- 304 stainless steel exterior and interior
- Anti-corrosion treated evaporator
- No condensate drain required
- 63mm dia. heavy-duty 1.2mm 304 stainless steel legs with adjustable feet
- Condensing unit removable through front of unit for service
- Easy clean interior

### Controls

#### Griddle

- Separate left and right side heat zones
- Two 90-300°C thermostats
- Large easy use control knobs - heat resistant reinforced
- Easy view control settings on knobs
- Flame failure pilot burners
- Piezo ignition to each pilot burner
- Over-temperature safety cut-outs

#### Refrigerated base

- Digital control electronic thermostat
- Automatic defrost
- Automatic evaporation of defrost water
- -2 to +8°C temperature range

### Cleaning and Servicing

- All models with easy clean stainless steel external finish
- Plate is finished front and rear with overlap construction to remove cleaning traps
- Control service and gas conversion through front of unit
- Burner service requires plate removal
- Refrigerated Base condenser removable through front of unit

# GAS GRIDDLE 900mm

GP516-B, GP516-CB, GP516-LS, GP516-RB

## Specifications

### Griddle

**Burner**  
Two 3 bar chromed steel burners  
Individual pilot, flame failure and piezo ignition

**Gas power**  
80MJ/hr, 22.2kW

**Plate**  
Cooking surface 892mm x 530mm, 4728cm<sup>2</sup>

**Gas connection**  
R<sup>3</sup>/<sub>4</sub> (BSP) male  
All units supplied with Natural and LP gas regulator

### Refrigerated base

**Type**  
Ventilated system

**Refrigerant**  
R134a (160grams)

**Climate classification**  
T – tropical

**Electrical connection**  
220-240Vac, 50Hz, 1.8A, 1P+N+E  
3 pin 10A plug cordset fitted

### Dimensions

**Bench models**  
Width 900mm  
Depth 812mm  
Height 315mm  
Incl. splashback 485mm

**All models (excluding Bench model)**  
Width 900mm  
Depth 812mm  
Height 915mm  
Incl. splashback 1085mm

### Nett weight

**Bench and Leg Stand models**  
157kg

**Cabinet Base and Refrigerated Base models**  
200kg

### Packing data

**Bench and Leg Stand models**  
0.55m<sup>3</sup>, 222kg  
Width 945mm  
Depth 870mm  
Height 665mm

**Cabinet Base and Refrigerated Base models**  
1.03m<sup>3</sup>, 265kg  
Width 945mm  
Depth 870mm  
Height 1255mm

### Gas types

Available in Natural gas and LP gas,  
please specify when ordering  
Units supplied complete with gas type  
conversion kits  
Other gas types on request

### Options

Adjustable feet at rear  
Joining caps  
Castors  
Ribbed plate options  
Mirror chromed plate options

GP516-B

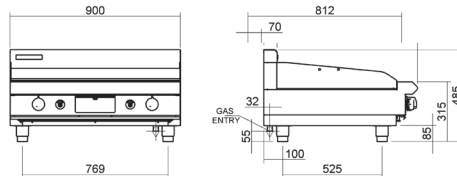

GP516-LS

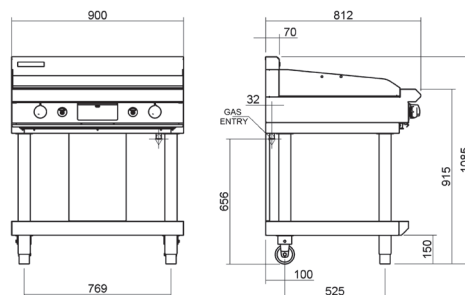

GP516-CB

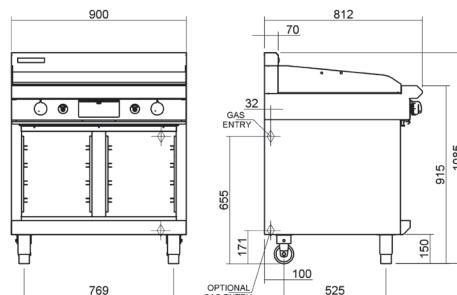

GP516-RB

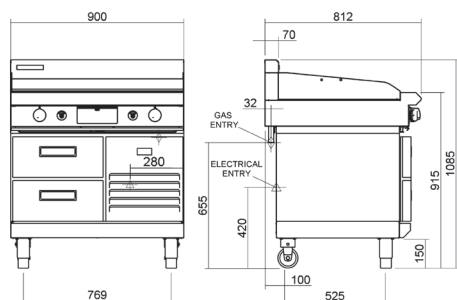

PLAN

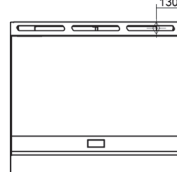

[moffat.com.au](http://moffat.com.au)  
[moffat.co.nz](http://moffat.co.nz)

Australia  
[moffat.com.au](http://moffat.com.au)

### Moffat Pty Limited

Victoria/Tasmania  
740 Springvale Road  
Mulgrave, Victoria 3170  
Telephone +613-9518 3888  
Facsimile +613-9518 3833  
[vsales@moffat.com.au](mailto:vsales@moffat.com.au)

New South Wales  
Telephone +612-8833 4111  
[nswsales@moffat.com.au](mailto:nswsales@moffat.com.au)  
South Australia  
Telephone +613-9518 3888  
[vsales@moffat.com.au](mailto:vsales@moffat.com.au)

Queensland  
Telephone +617-3630 8600  
[qldsales@moffat.com.au](mailto:qldsales@moffat.com.au)

Western Australia  
Telephone +618-9413 2400  
[wasales@moffat.com.au](mailto:wasales@moffat.com.au)

New Zealand  
[moffat.co.nz](http://moffat.co.nz)

### Moffat Limited

Rolleston  
45 Illinois Drive  
Izone Business Hub  
Rolleston 7675  
Telephone +64 3-983 6600  
Facsimile +64 3-983 6660  
[sales@moffat.co.nz](mailto:sales@moffat.co.nz)

Auckland  
Telephone +64 9-574 3150  
[sales@moffat.co.nz](mailto:sales@moffat.co.nz)



Cert. No. 6898

In line with policy to continually develop and improve its products, Moffat Limited reserves the right to change specifications and design without notice.

© Copyright Moffat Ltd  
AN.BSE.01.2020