



# VERRO SERIES: VOV-SB4-CBR3

## Four Burner Oven with 300mm Char Broiler

Project: \_\_\_\_\_ Item: \_\_\_\_\_



VOV-SB4-CBR3

### Standard Features:

- AISI 304 grade stainless steel
- Heavy duty complete stainless-steel cabinet frame
- 31mj black enameled Italian made top burner
- Removable pressed top spillage tray for easy cleaning
- Removable heavy duty 2-piece burners for easy cleaning
- Solid steel base plate allows for even heat distribution
- Heavy duty fully insulated dropdown door
- 29MJ oven burner
- Biggest gastronorm capacity in its class
- German made thermostat ensures accurate temperature control
- Multi-setting gas valve as standard allowing for greater regulation of flame setting
- Pilot take off fitted as standard
- Heavy duty Italian made vitreous enameled trivets
- Easy access to all components for servicing and adjustment
- Heavy duty cast iron J grates (CBR section)
- 24-month warranty

### Options:

- Castors
- Plinth mounted
- Flame failure
- Natural or LP gas

### Specifications:

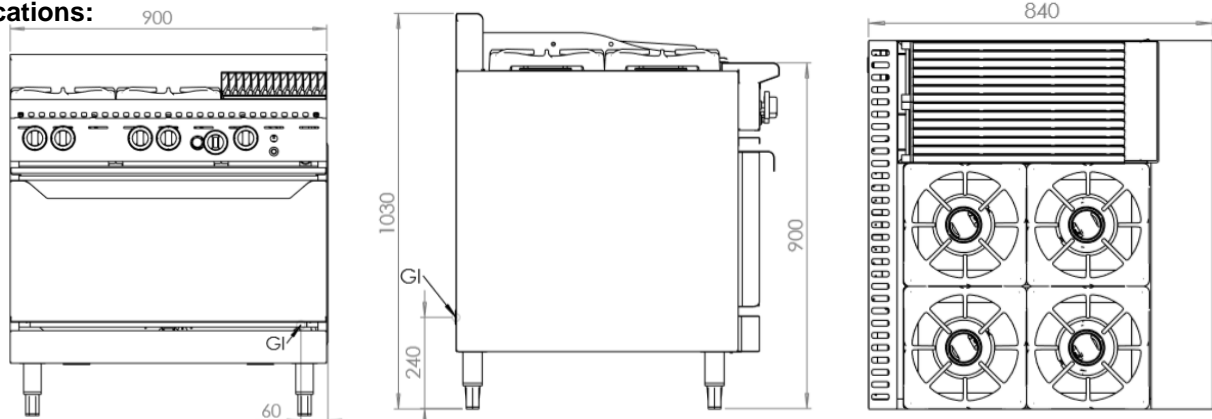

MODEL	LENGTH (mm)	DEPTH (mm)	HEIGHT (mm)	GAS CONSUMPTION (Mj/h)	
				NG	LPG
VOV-SB4-CBR3	900	840	1030	186	159

### Connections:

GAS (GI) (BSP)	SUPPLY PRESSURE (kPa)	
	NG	LPG
3/4" (M)	1.0	2.6

- Regulator is included in the unit
- **Must** be installed by an authorised installer

**Due to ongoing Product Development, Product Improvement and Research, B+S Commercial Kitchens reserves the right to alter specification without notice.**



B+S Commercial Kitchens  
57 Plateau Road Reservoir VIC 3073 Australia | +61 3 9469 4754  
info@bscommercialkitchens.com | www.bscommercialkitchens.com

