



RAPID FRYER SERIES: RF-2E

Two Pan Four Basket Electric Fryer - 13.5 + 13.5 Kilowatt

Project: _____ Item: _____



RF-2E

Standard Features:

- AISI Grade Stainless Steel
- Heavy duty complete stainless steel frame
- Stainless steel constructed pans - 2mm Thick
- Highly efficient heating elements
- Built-in thermal insulation layer saves energy and improves efficiency
- Easy to use programmable display controller
- Over-temperature safety cut-out switch
- Temperature range: 90°C - 190°C
- 40L oil capacity per pan
- Inbuilt oil filtration system and removable refill spout
- Removable oil collection tank
- Easily movable unit with lockable front castors
- Baskets Provided: 335mm L x 165mm W x 150mm H (2 per tank)
- Pan Dimensions: 340mm W x 410mm D x 385mm H (Height from base to max oil level mark is 280mm H)

Specifications:

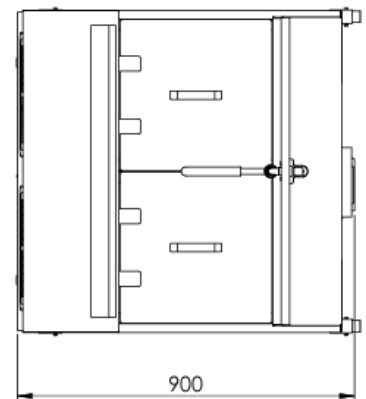
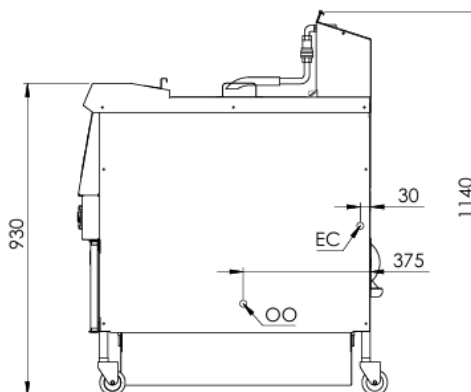
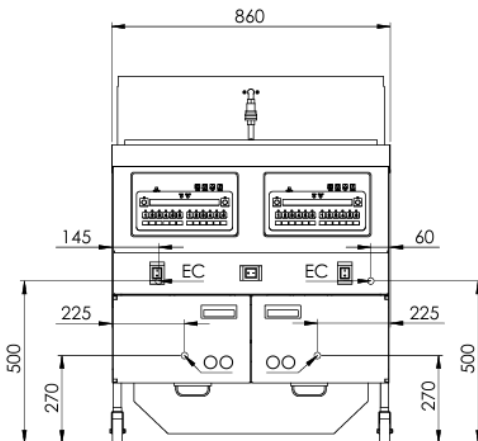

**INDUSTRY
KITCHENS**

www.industrykitchens.com.au 1800 611 058

MODEL	LENGTH (mm)	DEPTH (mm)	HEIGHT (mm)	NET WEIGHT (kg)
RF-2E	860	900	1140	185

Connections:

ELECTRICAL CONNECTION (EC)	ELECTRICAL SUPPLY REQUIREMENTS				
	VOLTAGE (V)	TYPE	FREQUENCY (Hz)	POWER (kW)	AMPS (A)
Hard Wired	400	3P+N+E	50/60	13.5 + 13.5	20

Must be installed by an authorised installer in accordance to **AS/NZS 3000** refer to **current version**

Due to ongoing Product Development, Product Improvement and Research, B+S Commercial Kitchens reserves the right to alter specification without notice.

Electromagnetic Compatibility: AS/NZS CISPR 14.1, EN IEC 55014-1:2021



B+S Commercial Kitchens
57 Plateau Road Reservoir VIC 3073 Australia | +61 3 9469 4754
info@bscommercialkitchens.com | www.bscommercialkitchens.com

