



# FOOD MIXER BM-5E 230/50-60/1

Table-top model with 5-lt / qt. bowl.



P/N 1500180



## FEATURES AND BENEFITS

- ✓ Professional food mixer for preparing dough (bread, cake...), egg whites (soufflés, meringue...), sauces (mayonnaise...) and minced meat mixtures.
- ✓ Equipped with an extractible safety guard.
- ✓ Continuous variable electronic speed control.
- ✓ Lever operated bowl lift.
- ✓ Double micro switch for bowl position and safety guard.
- ✓ NSF-International certified appliance (complying with Hygiene, Cleaning and Food Material regulations)

## SALES DESCRIPTION

Designed for light duty use.

## INCLUDES

- ✓ Stainless steel bowl.
- ✓ Beater spatula for soft dough.
- ✓ Spiral hook for heavy dough.
- ✓ Balloon whisk.

## ACCESSORIES

- Bowls for planetary mixers



**sammic** | [www.sammic.com](http://www.sammic.com)  
Food Service Equipment Manufacturer

Polígono Basarte, 1. phone +34 943 15 72 36  
20720 Azkoitia, Spain [sales@sammic.com](mailto:sales@sammic.com)



Project	Date
Item	Qty
Approved	

DYNAMIC PREPARATION  
PLANETARY MIXERS

product sheet  
updated 22/03/2019



# FOOD MIXER BM-5E 230/50-60/1

Table-top model with 5-lt / qt. bowl.



P/N 1500180

## SPECIFICATIONS

- Bowl capacity: 5 l
- Capacity in flour (60% water): 1 Kg
- Total loading: 300 W
- Electrical supply: 230 V / 50-60 Hz / 1 ~ (2.2 A)
- Plug: EU

### External dimensions (WxDxH)

- ✓ Width: 310 mm
- ✓ Depth: 382 mm
- ✓ Height: 537 mm
- Net weight: 13.7 Kg

### Crated dimensions

- 360 x 430 x 565 mm
- Gross weight: 17 Kg.

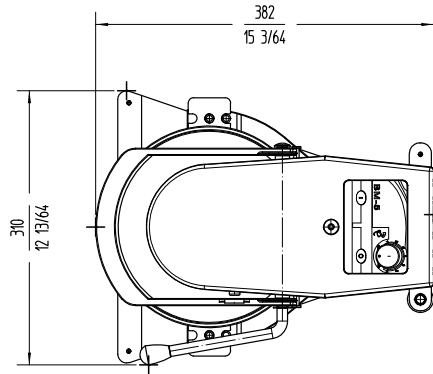
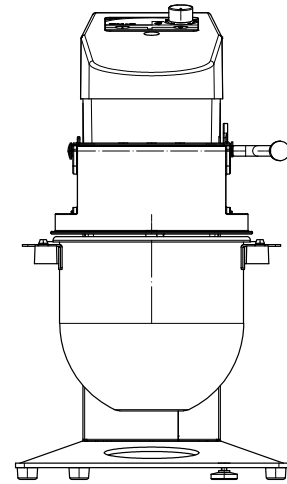
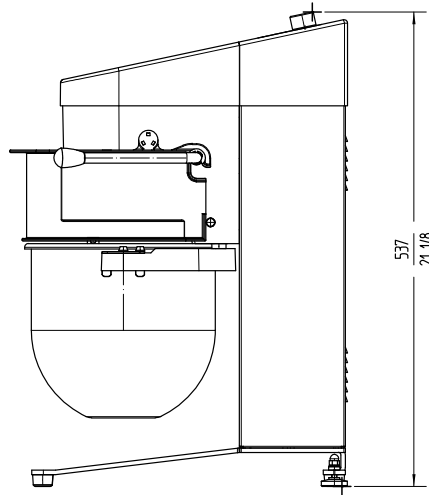

DYNAMIC PREPARATION  
PLANETARY MIXERS

**sammic** | www.sammic.com  
Food Service Equipment Manufacturer

Polígono Basarte, 1. phone +34 943 15 72 36  
20720 Azkoitia, Spain sales@sammic.com



Project

Date

Item

Qty

Approved

product sheet  
updated 22/03/2019