

# INDUSTRY KITCHENS

www.industrykitchens.com.au 1800 611 058

# apuro

## Planetary Mixer

### Instruction manual



**Model:**  
**CP921-A / DB266-A**

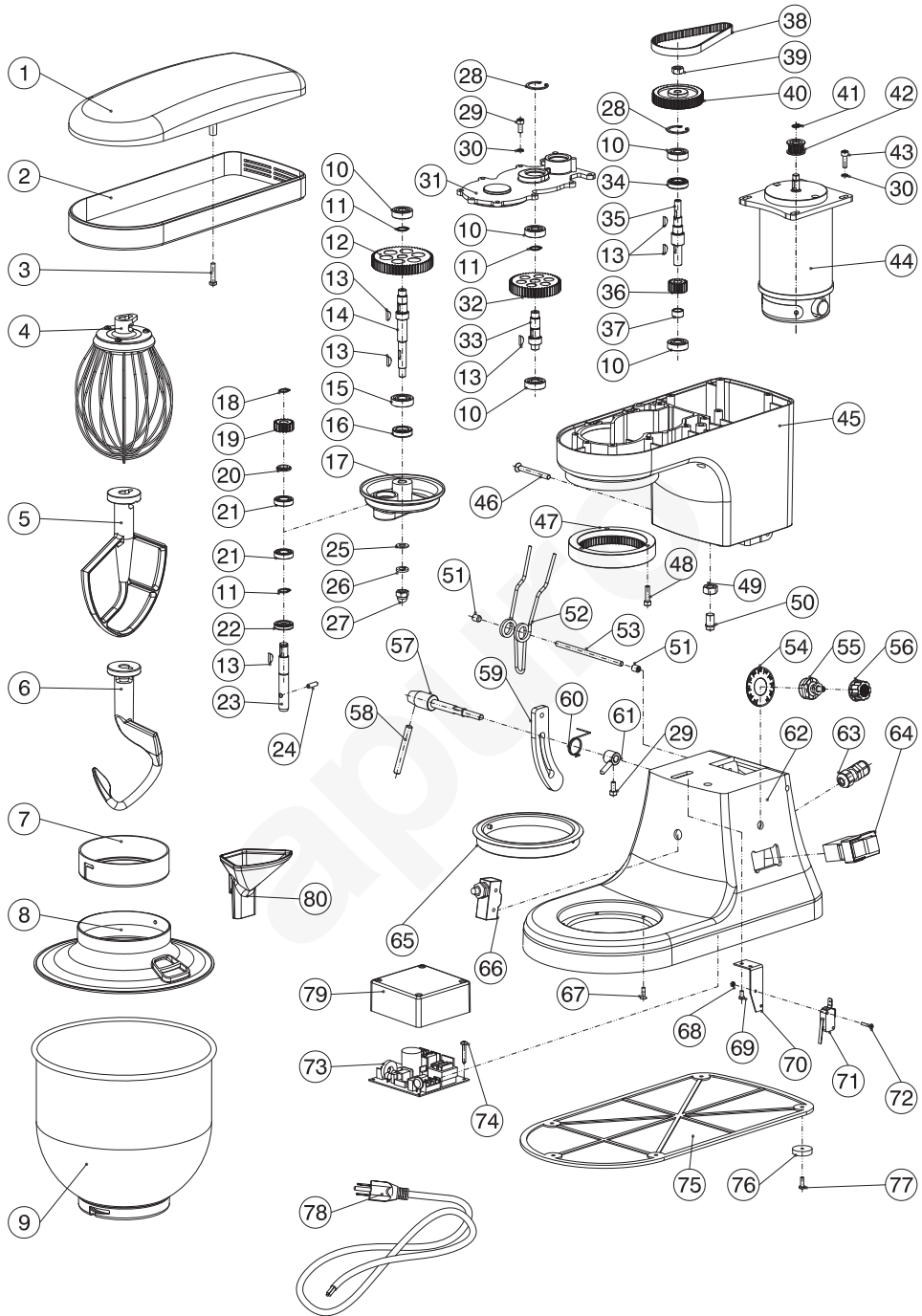

NO.	DESCRIPTION	QTY.	NO.	DESCRIPTION	QTY.
1	Cover	1 PC	41	Circlip For Shaft	1 PC
2	Band	1 PC	42	Small Synchronous Pulley	1 PC
3	Screw	2 PCS	43	Screw	4 PCS
4	Wire Whip	1 PC	44	Motor	1 PC
5	Flat Beater	1 PC	45	Rotating Base	1 PC
6	Dough Hook	1 PC	46	Screw	1 PC
7	Annulus Ring	1 PC	47	Inner Gear	1 PC
8	Safety Guard	1 PC	48	Screw	3 PCS
9	Bowl	1 PC	49	Nut	1 PC
10	Deep Groove Ball Bearing	5 PCS	50	Locating Pin	1 PC
11	Circlip For Shaft	3 PCS	51	Screw	2 PCS
12	Gear for Main Shaft	1 PC	52	Double Torsion Spring	1 PC
13	Woodruff Key	6 PCS	53	Rotating Shaft	1 PC
23	Planet Shaft	1 PC	54	Speed Mark	1 PC
24	Pin	1 PC	55	Switch Base	1 PC
14	Main Shaft	1 PC	56	Speed Control	1 PC
15	Deep Groove Ball Bearing	1 PC	57	Handle Spindle	1 PC
16	Oil Seal	1 PC	58	Handle	1 PC
17	Operation Frame	1 PC	59	Arc Slide Block	1 PC
18	Circlip For Shaft	1 PC	60	Torsion Spring	1 PC
19	Planet Gear	1 PC	61	Support Sleeve	1 PC
20	Planet Gear Pad	1 PC	62	Base	1 PC
21	Deep Groove Ball Bearing	2 PCS	63	Waterproof Joint	1 PC
22	Oil Seal	1 PC	64	On/Off Switch	1 PC
25	Flat Washer	1 PC	65	Bowl Seat	1 PC
26	Spring Washer	1 PC	66	Travel Switch	1 PC
27	Nut	1 PC	67	Screw	6 PCS
28	Circlip For Hole	2 PCS	68	Nut	2 PCS
29	Screw	9 PCS	69	Screw	3 PCS
30	Spring Washer	13 PCS	70	Distance Switch Support	1 PC
31	Support Cover	1 PC	71	Micro Switch/Distance Switch	1 PC
32	Gear	1 PC	72	Screw	2 PCS
33	Gear Shaft	1 PC	73	PCB	1 PC
34	Oil Seal	1 PC	74	Screw	4 PCS
35	Axle	1 PC	75	Base Plate	1 PC
36	Gear For Axle	1 PC	76	Rubber Pads	5 PCS
37	Bushing	1 PC	77	Screw	5 PCS
38	Synchronous Belt	1 PC	78	Plug	1 PC
39	Nut	1 PC	79	PCB Guard	1 PC
40	Large Synchronous Pulley	1 PC	80	Funnel	1 PC

## Safety Tips



**THE PLANETARY MIXER IS A DANGEROUS APPLIANCE AND MUST ONLY BE USED BY TRAINED PERSONNEL IN ACCORDANCE WITH THESE INSTRUCTIONS.**

- Position on a flat, stable surface.
- A service agent/qualified technician should carry out installation and any repairs if required. Do not remove any components on this product.
- Consult Local and National Standards to comply with the following:
  - Health and Safety at Work Legislation
  - Fire Precautions
  - Wiring Regulations
  - Building Regulations
- Always stand **BEHIND** the safety guard when operating the appliance.
- **DO NOT** place hands near the rotating attachments when in use. This can result in severe injury.
- **DO NOT** remove food from the appliance until the mixing attachments have come to a complete stop.
- **DO NOT** immerse the appliance in water.
- **DO NOT** attempt to mix items that this machine is not designed for. This can damage the mixing attachments.
- **DO NOT** use with a damaged mixing attachment.
- **DO NOT** bypass the safety interlocks.
- Always switch off and disconnect the power supply to the appliance when not in use.
- **NEVER** leave the appliance unattended when in use.
- The appliance is heavy. Take care when moving.
- This appliance must only be used in accordance with these instructions and by persons competent to do so.

- This appliance is not intended for use by persons (including children) with reduced physical, sensory or mental capabilities, or lack of experience and knowledge, unless they have been given supervision or instruction concerning use of the appliance by a person responsible for their safety.
- Children should be supervised to ensure that they do not play with the appliance.
- Keep all packaging away from children. Dispose of the packaging in accordance to the regulations of local authorities.
- If the power cord is damaged, it must be replaced by an Apuro agent or a recommended qualified technician in order to avoid a hazard.
- Never use accessories which are not recommended by the manufacturer. They could pose a safety risk to the user and might damage the appliance. Only use original parts and accessories.
- DO NOT use jet/pressure washers to clean the appliance.
- Apuro recommend that this appliance should be periodically tested (at least annually) by a Competent Person. Testing should include, but not be limited to: Visual Inspection, Polarity Test, Earth Continuity, Insulation Continuity and Functional Testing.

## Product Description

**CP921-A** - Tabletop Planetary Mixer - Black - 7Ltr

**DB266-A** - Tabletop Planetary Mixer - White - 7Ltr

## Introduction

The Apuro Planetary Mixer has been designed to mix a range of foodstuffs, varying from cream to dough.

Please take a few moments to carefully read through this manual. Correct maintenance and operation of this machine will provide the best possible performance from your Apuro product.

## Pack Contents

The following is included:

- Apuro Planetary Mixer
- Mixing Bowl
- Spiral Dough Hook
- Beater
- Whisk
- Instruction Manual
- Funnel

Apuro prides itself on quality and service, ensuring that at the time of packaging the contents are supplied fully functional and free of damage. Should you find any damage as a result of transit, please contact your Apuro dealer immediately.

## Installation

- Remove the appliance from all packaging.
- While positioning on a worktop, ensure the appliance is secured in position.
- **Note: Ensure the feet are level to reduce vibration during operation.**

## Assembly



### WARNING:

- **Ensure the appliance is switched off and disconnected from power supply before assembly/disassembly.**
- **Apuro accept no responsibility for any injury caused by incorrect assembly of this appliance.**
- **The bowl must be attached into position prior to starting the Planetary Mixer.**

1. Lift the handle clockwise (🔓 position) until the mixer head rises and rests stably.
2. Select the desired mixer attachment and fix onto the mixer head. Turn right to fix it into place.
3. Attach the bowl to the bowl seat. Turn clockwise to lock it into place. **Note:** Reverse the procedure to remove the bowl.
4. Lift and hold the handle (🔓 position) while lowering the mixer head fully. Then lower the handle counter-clockwise (🔒 position) and release to lock the mixer head in place.

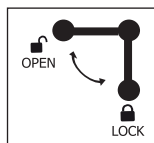



**Note: Ensure the mixer head is locked in place or the mixer will not work.**

## Changing the Mixer Attachment

1. Turn Off the appliance.
2. Raise the mixer head as instructed previously (Page 6).
3. Push the mixer attachment up and to the left to release.
4. Insert the desired attachment. Push up and to the right to lock it into place.
5. Lower the mixer head in place.

Apuro recommend the following uses for each attachment:

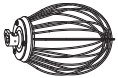
Mixer attachment		Intended use	Suitable speed
	Spiral Dough hook	Heavy mixes dough, pie pastry etc.	Slow
	Beater	Firm mixes light pastry, cake/biscuit mix, icings, fillings and mashed vegetables	Medium
	Whisk	Light mixes whipped cream, mayonnaise, egg whites, pancakes and soufflés	Fast

## Operation



- Ensure that these instructions have been read thoroughly and the operation of the appliance is fully understood before use.
- All personnel must be fully trained on the operation and safety precautions of the Planetary Mixer.

### Layout of Controls

- **START button:** Press to start the mixer.
- **STOP button:** Press to stop the mixer.
- **Speed control knob:** Use to set the speed of the mixer.



Speed control knob

### Mixing



**WARNING:** Always ensure the appliance is turned off before placing hands in the mixing bowl.



START button

STOP button

1. Raise the mixer head.
2. Fill the bowl.
3. Lower the mixer head and lock it in place.
4. Select the desired speed.



- Apuro recommend that you start with the slowest speed and increase the speed gradually as necessary.
- Ensure the mixer head and bowl are fully locked in place or the mixer will not work.

5. Press the START button to begin mixing.



**Note: If the appliance is straining to mix then turn the appliance Off and remove some of the contents from the bowl before restarting.**

6. After use, slowly turn the speed control knob to **MIN**. Then press the STOP button and disconnect the mixer from power supply.

### Mixing Capacity

Max Flour	Max Dough
1.5kg	2.4kg

### Overload protection

The appliance is featured with overload protection. In case of overload, the appliance will beep then stop working automatically.

1. Turn Off the mixer.
2. Reduce the load in the mixing bowl.
3. Press the START button to re-start.

## Cleaning, Care & Maintenance

- Always turn off the mixer and disconnect from the power supply before cleaning.
- Use warm soapy water to clean the bowl and mixing attachments. Do not use abrasive cleaning chemicals as these can leave harmful residues.
- Clean the exterior of the appliance with a damp cloth.
- Dry all parts thoroughly after cleaning.
- Do not use jet/pressure washers to clean the appliance.
- Clean the appliance regularly.
- **NO WATER INGRESS!**

## Troubleshooting

If your Apuro appliance develops a fault, please check the following table before making a call to the Helpline or your Apuro dealer.

Fault	Probable Cause	Solution
The appliance is not working	The unit is not switched on	Check the unit is plugged in correctly and switched on
	Plug or cord is damaged	Call Apuro agent or qualified Technician
	Power supply	Check power supply
	The overload protection has activated	See overload protection instructions
	Safety Guard not closed	Close Safety Guard fully
The mixer slows down	The mixing bowl is overloaded	Turn off the appliance and empty some of the contents
	Mixing speed too high or a wrong mixing attachment used	Select the suitable speed and mixing attachment
The appliance is noisy	Bowl or mixing attachment not correctly fitted	Remove and refit bowl/mixing attachment
	Bowl or mixing attachment deforms	Call Apuro agent or qualified Technician

## Technical Specifications

Model	Voltage	Power	Current	Dimensions H x W x D mm	Weight (kg)	Bowl Volume
CP921-A	220-240V~ 50-60Hz	270W	1.5A	410 x 420 x 230	15kg	7L
DB266-A						

## Electrical Wiring

The plug is to be connected to a suitable mains socket.

This appliance is wired as follows:

- Live wire (coloured brown) to terminal marked L
- Neutral wire (coloured blue) to terminal marked N
- Earth wire (coloured green/yellow) to terminal marked E

This appliance must be earthed.

If in doubt consult a qualified electrician.

Electrical isolation points must be kept clear of any obstructions. In the event of any emergency disconnection being required they must be readily accessible.

## Compliance

The product must not be disposed of as household waste. To help prevent possible harm to human health and/or the environment, the product must be disposed of in an approved and environmentally safe recycling process. For further information on how to dispose of this product correctly, contact the product supplier, or the local authority responsible for waste disposal in your area.

Apuro parts have undergone strict product testing in order to comply with regulatory standards and specifications set by international, independent, and federal authorities.

Apuro products have been approved to carry the following symbol:



**All rights reserved. No part of these instructions may be produced or transmitted in any form or by any means, electronic, mechanical, photocopying, recording or otherwise, without the prior written permission of Apuro.**

**Every effort is made to ensure all details are correct at the time of going to press, however, Apuro reserve the right to change specifications without notice.**

# DECLARATION OF CONFORMITY

- Conformanceverklaring • Déclaration de conformité • Konformitätserklärung • Dichiarazione di conformità •  
• Declaración de conformidad • Declaração de conformidade

<b>Equipment Type</b> • Uitrustingstype • Type d'équipement • Gerätetyp • Tipo di apparecchiatura • Tipo de equipo • Tipo de equipamento		<b>Model</b> • Modèle • Modell • Modello • Modelo • Malli
Black 7Ltr Tabletop Planetary Mixer White 7Ltr Tabletop Planetary Mixer		CP921-A DB266-A
<b>Application of Territory Legislation &amp; Council Directives(s)</b> Toepassing van Europese Richtlijn(en) • Application of la/des directive(s) du Conseil • Anwendbare EU-Richtlinie(n) • Applicazione delle Direttive • Aplicación de la(s) directiva(s) del consejo • Aplicação de directiva(s) do Conselho	<b>Electrical safety</b> EN454:2014 EN ISO 12100:2010 EN 1672-2:2005 +A1:2009  EN 62233:2008 <b>Electro-Magnetic Compatibility</b> EN 55014-1:2017 EN 55014-2:2015 EN IEC 61000-3-2:2019 EN 61000-3-3:2013 +A1:2019	
<b>Producer Name</b> • Naam fabrikant • Nom du producteur • Name des Herstellers • Nome del produttore • Nombre del fabricante • Nome do fabricante		<b>Apuro</b>

I, the undersigned, hereby declare that the equipment specified above conforms to the above Territory Legislation, Directive(s) and Standard(s).

Ik, de ondergetekende, verklaar hierbij dat de hierboven gespecificeerde uitrusting goedgekeurd is volgens de bovenstaande Richtlijn(en) en Standaard(en).

Je soussigné, confirme la conformité de l'équipement cité dans la présente à la / aux Directive(s) et Norme(s) ci-dessus  
 Ich, der/die Unterzeichnende, erkläre hiermit, dass das oben angegebene Gerät der/den oben angeführten Richtlinie(n) und Norm(en) entspricht.

Il sottoscritto dichiara che l'apparecchiatura di sopra specificata è conforme alle Direttive e agli Standard sopra riportati.  
 El abajo firmante declara por la presente que el equipo arriba especificado está en conformidad con la(s) directiva(s) y estándar(es) arriba mencionadas.

Eu, o abaixo-assinado, declaro que o equipamento anteriormente especificado está em conformidade com a(s) anterior(es) Directiva(s) e Norma(s)

**Date** • Data • Date • Datum • Data •  
 Fecha • Data

**Signature** • Handtekening • Signature  
 • Unterschrift Firma • Firma •  
 Assinatura

**Full Name** • Volledige naam • Nom et  
 prénom • Vollständiger Name • Nome  
 completo • Nombre completo • Nome  
 por extenso

**Position** • Functie • Fonction • Position  
 • Qualifica • Posición • Função

**Producer Address** • Adres fabrikant •  
 Adresse du producteur • Anschrift des  
 Herstellers • Indirizzo del produttore •  
 Dirección del fabricante • Morada do  
 fabricante

18<sup>th</sup> May 2021

DocuSigned by:

Ashley Hooper  
 B39382C9FD9C478...

Ashley Hooper

Technical & Quality Manager

Fourth Way,  
 Avonmouth,  
 Bristol,  
 BS11 8TB  
 United Kingdom

DocuSigned by:

Josie Holt  
 3582E210C4054DA...

Josie Holt

Commercial Manager/ Responsible  
 Supplier

15 Bagdally Road,  
 Campbelltown  
 NSW 2560







CP921-A\_DB266-A\_A5\_v1\_20210520