

INDUSTRY KITCHENS

www.industrykitchens.com.au 1800 611 058

apuro

Vacuum pack machine

Instruction manual



**Model:
CN514-A**

Safety Instructions

- Position on a flat, stable surface.
- A service agent/qualified technician should carry out installation and any repairs if required. Do not remove any components on this product.
- Consult Local and National Standards to comply with the following:
 - Health and Safety at Work Legislation
 - Fire Precautions
 - Wiring Regulations
 - Building Regulations
- DO NOT immerse the appliance in water.
- The sealing bar becomes hot during use. DO NOT touch the sealing bar during or immediately after operation.
- Do not turn Off at the plug to halt operation; always use the **Cancel** button.
- Do not use the appliance for anything other than its intended use.
- Only use bags recommended by the supplier/manufacturer with the appliance.
- Always switch off and disconnect the power supply to the appliance when not in use.
- Not suitable for outdoor use.
- Keep all packaging away from children. Dispose of the packaging in accordance to the regulations of local authorities.
- If the power cord is damaged, it must be replaced by an Apuro agent or a recommended qualified technician in order to avoid a hazard.
- Apuro recommend that this appliance should be periodically tested (at least annually) by a Competent Person. Testing should include, but not be limited to: Visual Inspection, Polarity Test, Insulation Continuity and Functional Test.

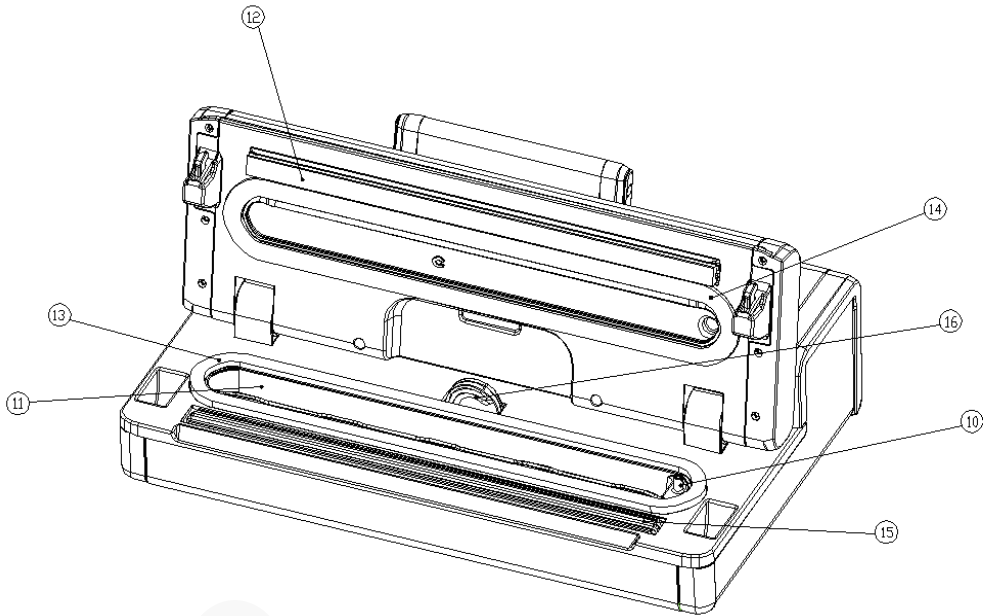

Controls / Features

1. Vacuum & Seal

Starts the automatic operation of vacuuming the bag and then automatically seals the bag when vacuum is complete.

2. Pulse vacuum

Press this button, and the device starts vacuuming; release the button and it will stop. This process can be repeated. Then press "manual seal" when desired vacuum has been reached to seal. Different vacuum pressure according to different types of foods can be chosen.

3. Sealing time

Three settings for choosing the best sealing time:

- Normal button : for dry bags and items without moisture, short sealing time (uses single sealing bar).
- Middle button: for wet bags or items with a little moisture, extended sealing time (uses single sealing bar).
- Extended button: for wet bags or items with high moisture, extended sealing time (uses double sealing bar).
- Default setting is Normal setting for dry bags and shorter sealing time.

4. Pressure

Two buttons for choice of different vacuum pressure:

- Normal button: for goods to be packed under normal vacuum pressure ;
- Gentle button: for soft & crushable items where less vacuum pressure is desired.
- Default setting is normal vacuum pressure.

5. Canister

For vacuuming canisters, jar lids, wine stoppers or other accessories through a hose.

6. Manual Seal

This button provides two functions:

- To seal the open end of a bag without vacuuming, i.e. to make a bag from a bag roll
- When the automatic "Vacuum & seal" function is in operation, this button stops the motor pump and immediately starts to seal the bag so vacuum pressure inside the bag can be controlled by the operator, to avoid the crushing of delicate items.

7. Hose port

Insert hose for external accessories such as canister and wine stopper.

8. Cancel

Stops the machine when in working mode.

9. Ready Indicators

Shows that the device is on and the lid is closed. If the LED blinks, wait for blinking to stop before you start next operation.

10. Air intake

Air intake connects with vacuum chamber and pump. Do not cover the intake when placing bag for vacuum & Seal operation.

11. Vacuum chamber

Position the open end of the bag inside the chamber. Air is drawn out of the bag.

12. Sealing strip

Place the bag to be sealed over this strip. Clean and dry or replace when dirty, distorted or broken.

13. Lower gasket

Clean and dry or replace when dirty, distorted or broken.

14. Upper gasket

Clean and dry or replace when dirty, distorted or broken.

15. Sealing element

Teflon-coated heating element which heats and seals the bag

16. Bag Cutter**17. Front handle**

Press down to lock the cover. Pull up to open the cover.

18. LED Indicator

Indicates the status of vacuum or sealing process, and the status of the machine settings.

19. Pressure gauge

Displays vacuum pressure

Operation

The Vacuum Pack Machine automatically comes on when plugged in.

The Vacuum Pack Machine is now ready for use.

Vacuum Packing Food (Automatic Vacuum and Seal)

1. Place the food inside in the bag and remove any excess liquid or food residue.
2. Allow minimum of 25mm-50mm of space at the top of bag to ensure a good seal.
3. Place the open end of the bag across the Sealing Strip, keeping opening within the chamber ring and close lid. Press down handle, Ready light will illuminate.
4. Select sealing time depending on moisture content of food, select pressure of vacuum depending on items to be packed
5. For Automatic function press "**Vacuum & Seal**" button. Indicator light will illuminate.
6. Vacuum pump will engage until required vacuum level is achieved. Machine will automatically go into seal mode.
7. Manual Seal indicator light will flash as the machine starts to seal.
8. When sealing is complete Vacuum & Seal and manual Seal indicators will switch off. Unlock bag using handle.
9. Remove bag and inspect bag and seal.
(Note: A good seal will look clear upon inspection. If the seal is spotty, incomplete, wrinkled, white or milky, remove sealed portion and run vacuum and seal process again.)
10. To abort process, press "**Cancel**" button. Machine will stop.

Vacuum Packing Food (Using Pulse Function)

1. Place the food inside in the bag and remove any excess liquid or food residue.
2. Allow minimum of 25mm-50mm of space at the top of bag to ensure a good seal.
3. Place the open end of the bag across the Sealing Strip, keeping opening within the chamber ring and close lid. Press down handle, Ready light will illuminate.
4. Press the Pulse button, vacuuming will start. Release button to stop vacuuming. Repeat until desired level of Vacuum is achieved.
5. Press Manual Seal button to seal bag
6. Remove bag and inspect bag and seal.
(Note: A good seal will look clear upon inspection. If the seal is spotty, incomplete, wrinkled, white or milky, remove sealed portion and run vacuum and seal process again.)
7. To abort process, press "**Cancel**" button. Machine will stop.

Using the "Seal Only" Function

1. Place the open end of the bag across the Sealing Strip, keeping opening within the chamber ring and close lid. Press down handle, ready light will illuminate.
2. Press the **Manual Seal** button.
3. Manual Seal Indicator light will illuminate as the machine starts to seal
4. When sealing is complete Manual Seal indicator will switch off. Unlock bag using handle.
5. Remove bag and inspect bag and seal.
(Note: A good seal will look clear upon inspection. If the seal is spotty, incomplete, wrinkled, white or milky, remove sealed portion and run vacuum and seal process again.)

Cleaning, Care & Maintenance



Switch off and disconnect from the power supply before cleaning.

Always allow to cool before cleaning.

WARNING: Do not allow any water to spill into the appliance when cleaning.

- Use warm, soapy water and a damp cloth to clean the appliance.
- Dry thoroughly after cleaning.

Troubleshooting

A qualified technician must carry out repairs if required.

| Fault | Probable Cause | Solution |
|--|---|---|
| The appliance is not working | The unit is not switched on | Check the unit is plugged in correctly and switched on |
| | Plug or lead is damaged | Replace plug or lead |
| | Mains power supply fault | Check mains power supply |
| Appliance does not remove all the air from the bag | Open end of bag not completely inserted | Open lid and reposition bag |
| | Gaskets dirty | Clean gaskets |
| | Open end of bag is dirty | Clean bag |
| | Bag may be punctured | Replace bag |
| | Incorrect bags used | Call Vacuum Pack machine supplier |
| | Suction nozzle blocked | Clear suction nozzle |
| | Lid is not locked into position correctly | Ensure lid is locked in position correctly |
| Bags are not sealing correctly | Moisture in bag under the sealing bar | Ensure inside of the bag is dry and free from moisture where it is to be sealed |
| | Incorrect bags used | Call Vacuum Pack machine supplier |
| | End of bag not placed above sealing bar | Move end of bag over sealing bar |

Technical Specifications

Note: Due to our continuous improvement process, the product specifications are subject to change without notice.

| Model | Voltage | Power | Vacuum Pressure (approx.) | Dimensions h x w x d mm | Weight (kg) |
|----------------|-------------------|-------|---------------------------|-------------------------|-------------|
| CN514-A | 220-240V~ 50Hz | 130W | -0.90Bar | 125 x 400 x 265 | 3.4 |

Electrical Wiring

The plug is to be connected to a suitable mains socket.

This appliance is wired as follows:

- Live wire (coloured brown) to terminal marked L
- Neutral wire (coloured blue) to terminal marked N

If in doubt consult a qualified electrician.

Electrical isolation points must be kept clear of any obstructions. In the event of any emergency disconnection being required they must be readily accessible.

Compliance

The product must not be disposed of as household waste. To help prevent possible harm to human health and/or the environment, the product must be disposed of in an approved and environmentally safe recycling process. For further information on how to dispose of this product correctly, contact the product supplier, or the local authority responsible for waste disposal in your area.

Apuro parts have undergone strict product testing in order to comply with regulatory standards and specifications set by international, independent, and federal authorities.

Apuro products have been approved to carry the following symbol:



All rights reserved. No part of these instructions may be produced or transmitted in any form or by any means, electronic, mechanical, photocopying, recording or otherwise, without the prior written permission of Apuro.

Every effort is made to ensure all details are correct at the time of going to press, however, Apuro reserve the right to change specifications without notice.

DECLARATION OF CONFORMITY

- Conformiteitsverklaring • Déclaration de conformité • Konformitätserklärung • Dichiarazione di conformità •
- Declaración de conformidad • Declaração de conformidade

| | |
|---|---|
| Equipment Type • Uitrustingstype • Type d'équipement • Gerätetyp • Tipo di apparecchiatura • Tipo de equipo | Model • Modèle • Modell • Modello • Modelo |
| Vacuum Pack Machine Stainless Steel | CN514-A |
| Application of Territory Legislation & Council Directives(s) Toepassing van Europese Richtlijn(en) • Application de la/des directive(s) du Conseil • Anwendbare EU-Richtlinie(n) • Applicazione delle Direttive • Aplicación de la(s) directiva(s) del consejo | Electrical Safety IEC 60335-1:2010 +A1:2013 +A2:2016 IEC 60335-2-45:2002 +A1:2008 +A2:2011 Electro-Magnetic Compatibility (EMC) EN IEC 55014-1: 2021 EN IEC 55014-2: 2021 EN IEC 61000-3-2: 2019+A1: 2021 EN 61000-3-3: 2013+A1: 2019+A2: 2021 |
| Manufacturer Name • Naam fabrikant • Nom du fabricant • Name des Herstellers • Nome del fabbricante • Nombre del fabricante | Apuro |

I, the undersigned, hereby declare that the equipment specified above conforms to the above Territory Legislation, Directive(s) and Standard(s).

Ik, de ondergetekende, verklaar hierbij dat de hierboven gespecificeerde uitrusting goedgekeurd is volgens de bovenstaande Richtlijn(en) en Standaard(en).

Je soussigné, confirme la conformité de l'équipement cité dans la présente à la / aux Directive(s) et Norme(s) ci-dessus
Ich, der/die Unterzeichnende, erkläre hiermit, dass das oben angegebene Gerät der/den oben angeführten Richtlinie(n) und Norm(en) entspricht.

Il sottoscritto dichiara che l'apparecchiatura di sopra specificata è conforme alle Direttive e agli Standard sopra riportati.
El abajo firmante declara por la presente que el equipo arriba especificado está en conformidad con la(s) directiva(s) y estándar(es) arriba mencionadas.

Date • Data • Date • Datum • Data
• Fecha

28th Aug 2024

Signature • Handtekening • Signature
• Unterschrift Firma • Firma

DocuSigned by:

Ashley Hooper
B39382C9FD9C478...

DocuSigned by:

Brendan
B1E11001D0DFE8483...

Full Name • Volledige naam • Nom et prénom • Vollständiger Name
• Nome completo • Nombre completo

Position • Functie • Fonction
• Position • Qualifica • Posición

Group Head of Product Quality & Compliance

Commercial Manager/ Responsible Supplier

Manufacturer Address • Adres fabrikant • Adresse du fabricant • Adresse des Herstellers • Indirizzo del fabbricante • Dirección del fabricante

Fourth Way,
Avonmouth,
Bristol,
BS11 8TB
United Kingdom

15 Badgally Road,
Campbelltown
NSW 2560





CN514-A_A5_v3_2024/09/02