

# 500-1DN/2DN/3DN Drawer Warmers



CE

Designed for both durability and exceptional food quality, Alto-Shaam's warming drawers seamlessly integrate into any kitchen layout where hot and fresh, ready-to-serve food needs to stay within easy reach. Featuring Halo Heat® technology, these drawers hold food at optimal serving temperatures without added water or harsh heating elements—preserving taste, texture, and freshness. Choose from flexible configurations: install in cabinets or counters, or stack units to make the most of your space.

Alto-Shaam's warming drawers feature a durable, non-magnetic, stainless steel exterior and removable stainless steel drawer rail supports. Each drawer includes one (1) GN 1/1 stainless steel pan—152mm deep. The unit is operated via an ON/OFF power switch and up and down arrow buttons on a digital display. It also includes a heat indicator light and a temperature display button.



## Standard features

- Halo Heat...a controlled, uniform heat source that gently surrounds foods for better appearance, taste, and longer holding life.
- Product moisture is retained without adding water.
- Digital control senses temperature drops faster, providing quick heat recovery time.
- Can be built into cabinets or counters. Built-in trim kits are available.
- Stackable design.
- Vented for optimal moisture control.



TEMPERATURE

Temperature range: 16°C to 93°C



CAPACITY

Size	Pan Quantity	Product Weight per Drawer (kg)
<b>500-1DN</b>	One (1) GN 1/1	19
<b>500-2DN</b>	Two (2) GN 1/1	19
<b>500-3DN</b>	Three (3) GN 1/1	19



ELECTRIC

## Power Options and Cord/Plug Assemblies

**NOTE:** All cord/plug assemblies are 1.82M long.

### 230V

- 230V/50 Hz/1 Ph, CEE 7/7 [5038471]
- 230V/50 Hz/1 Ph, BS-1363 [5038472]
- 230V/50 Hz/1 Ph, CH2-16P [5038473]
- 230V/50 Hz/1 Ph, AS/NZS 3112-2000 [5038474]
- 230V/50 Hz/1 Ph, TYPE M INI-16P [5038475]

# 500-1DN/2DN/3DN Drawer Warmers **ALTO-SHAAM**

## DIMENSIONS

### 500-1DN

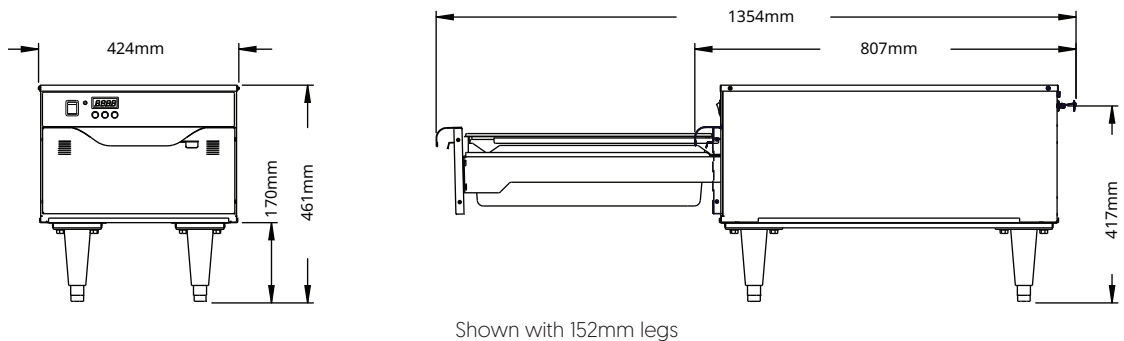
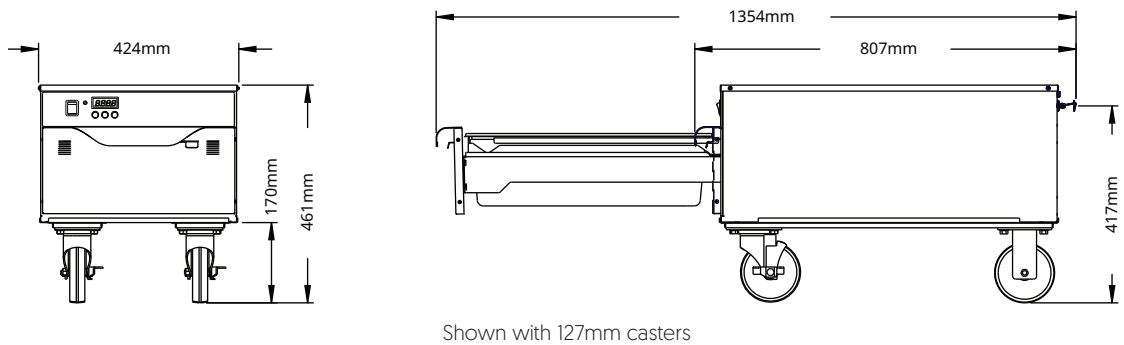
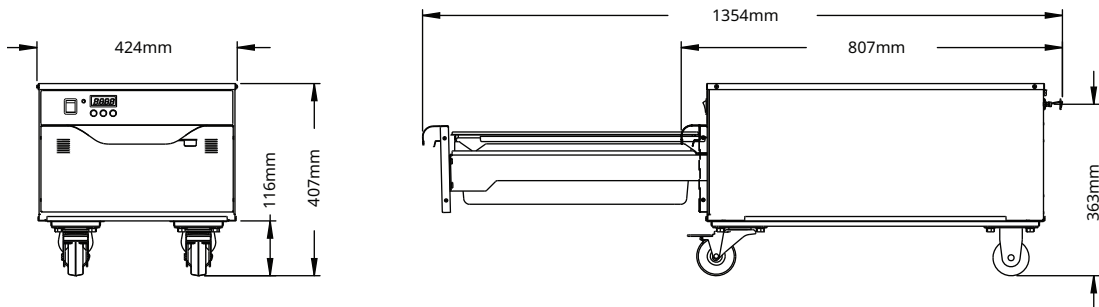
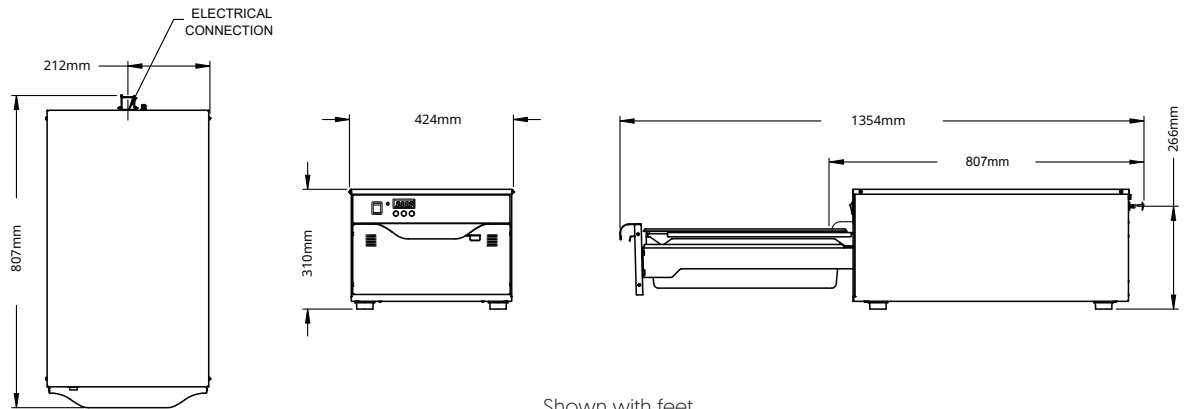

# 500-1DN/2DN/3DN Drawer Warmers **ALTO-SHAAM**

## DIMENSIONS

### 500-2DN

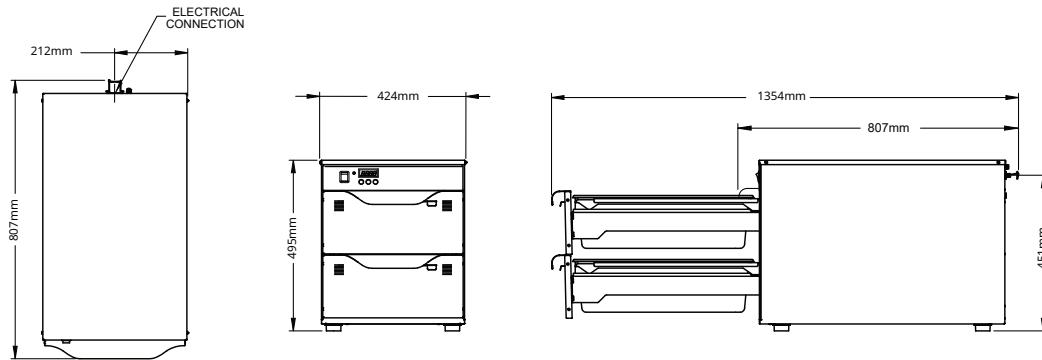

Shown with feet

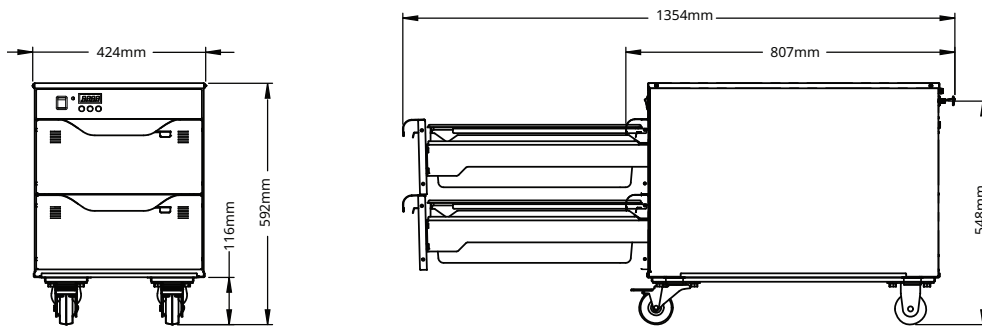

Shown with 76mm casters

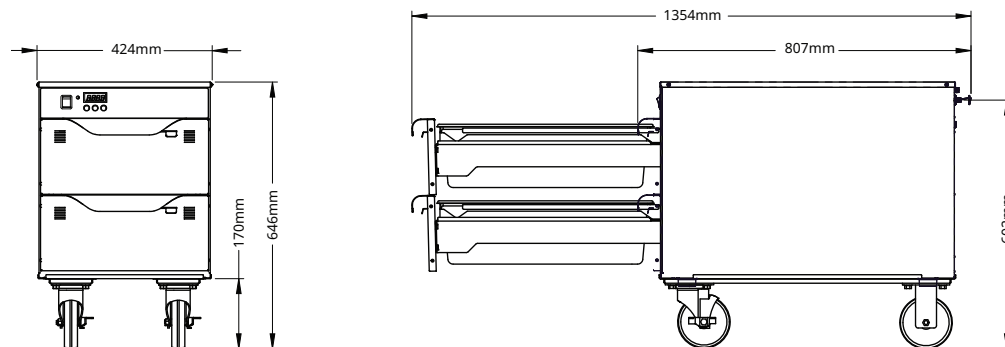

Shown with 127mm casters

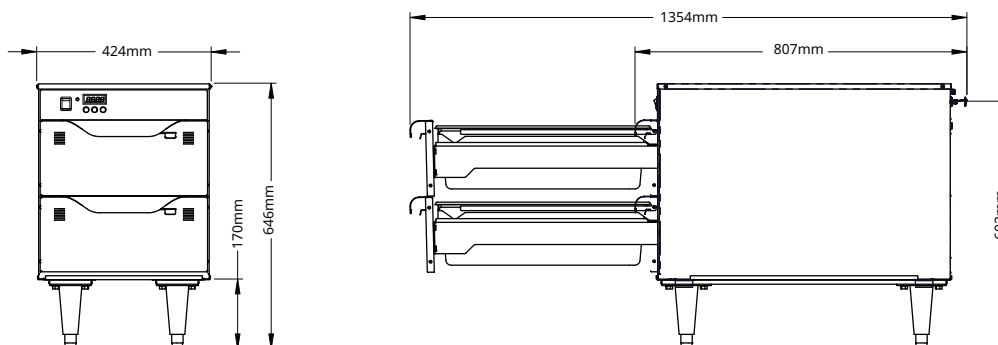

Shown with 152mm legs

# 500-1DN/2DN/3DN Drawer Warmers ALTO-SHAAM.

## DIMENSIONS

### 500-3DN

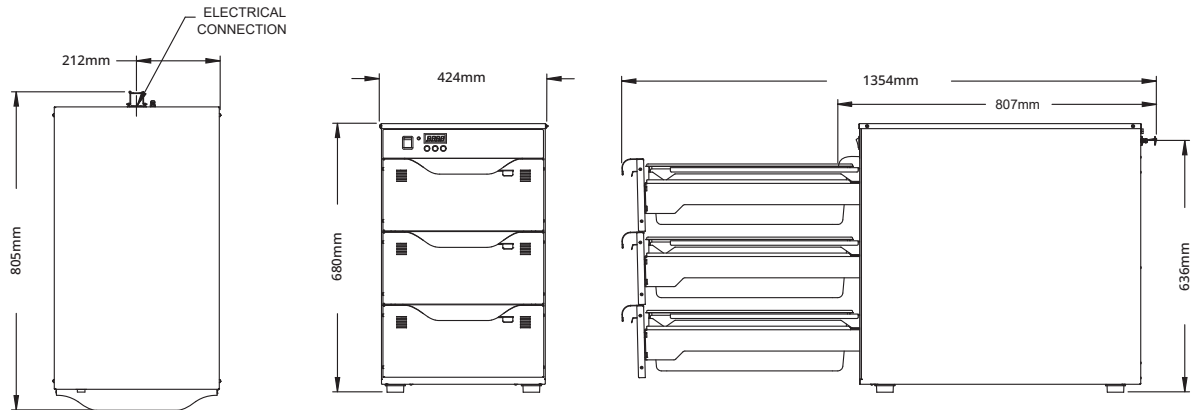

Shown with feet

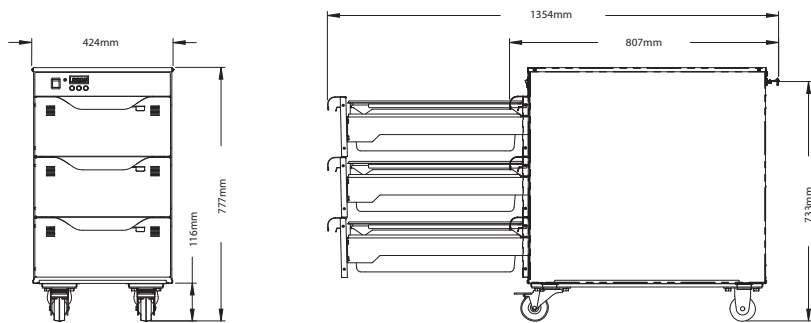

Shown with 76mm casters

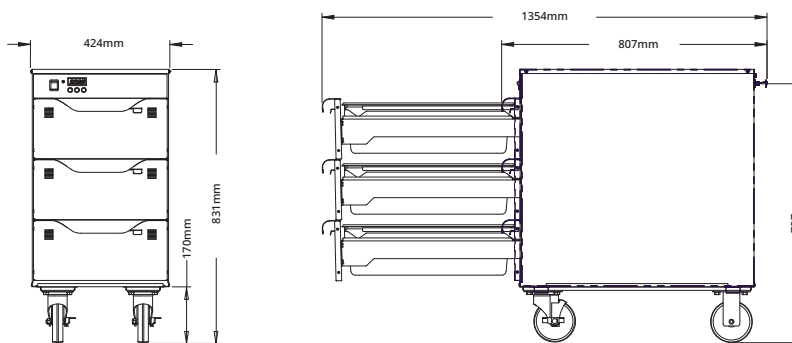

Shown with 127mm casters

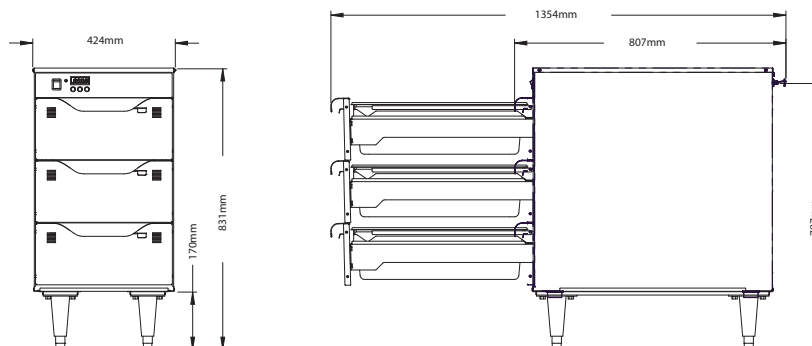

Shown with 152mm legs

# 500-1DN/2DN/3DN Drawer Warmers



## CUT-OUT DIMENSIONS

500-1DN 5038449  
TRIM KIT DIMENSIONS

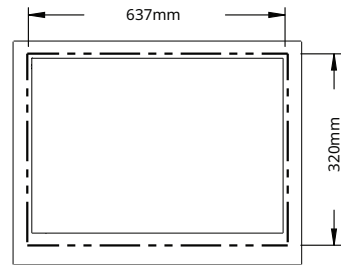
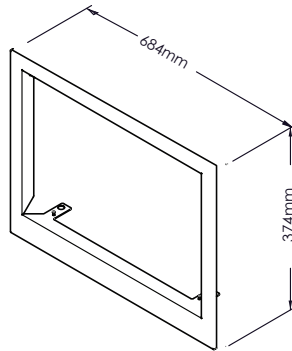

CUT-OUT DIMENSIONS

500-2DN 5038451  
TRIM KIT DIMENSIONS

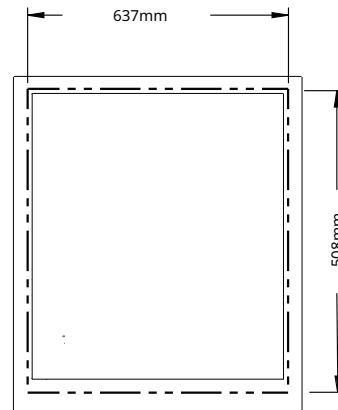
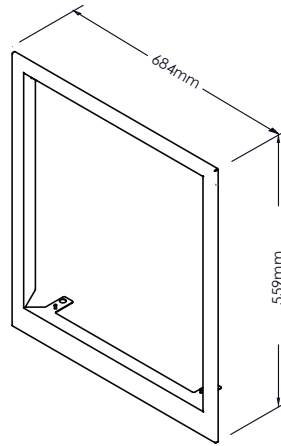

CUT-OUT DIMENSIONS

500-3DN 5038453  
TRIM KIT DIMENSIONS

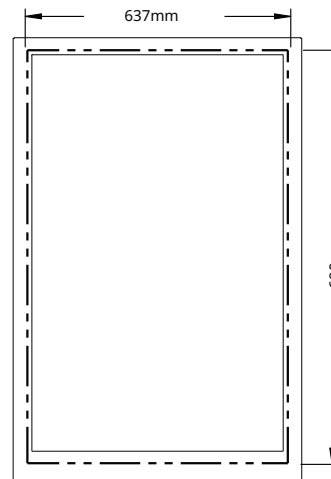
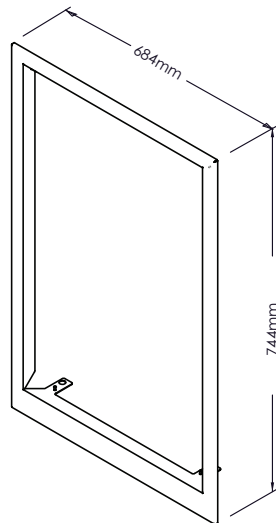

CUT-OUT DIMENSIONS

# 500-1DN/2DN/3DN Drawer Warmers **ALTO-SHAAM**



**CLEARANCE**

Top: ..... 51mm  
 Left: ..... 25mm  
 Right: ..... 25mm  
 Back: ..... 76mm



**REQUIREMENTS**

- Drawer warmer must be installed level.
- Drawer warmer must not be installed in any area where it may be affected by steam, grease, dripping water, extreme temperatures, or any other severely adverse conditions.



**HEAT**

## Heat of rejection

	Heat Gain qs, BTU/hr	Heat Gain qs, kW
<b>500-1DN</b>	262	0.08
<b>500-2DN</b>	262	0.08
<b>500-3DN</b>	262	0.08

## Options and Accessories

- Perforated pan grid, 381mm x 508mm [1231]
- Perforated pan grid, 305mm x 508mm GN1/1 [16642]
- Wire grate, stainless 460mm x 254mm x 19mm [SH-47573]
- Wire grate, chrome 460mm x 254mm x 19mm [SH-47325]

## Extended warranty

- One-year warranty extension



**WEIGHTS**

Size	Net Weight (est.)	Shipping Weight (est.)	Carton Dimensions (L x W x H)
<b>500-1DN</b>	30 kg	34 kg	838mm x 533mm x 381mm
<b>500-2DN</b>	45 kg	51 kg	838mm x 533mm x 559mm
<b>500-3DN</b>	59 kg	66 kg	838mm x 533mm x 737mm



**ELECTRIC**

500-D/DN/DI	V	Ph	Hz	A	Breaker (A)	kW
230V	230	1	50/60	12	16	2.8

Electrical connections must meet all applicable federal, state, and local codes.

## CONTACT US

W164 N9221 Water Street | Menomonee Falls, Wisconsin 53051 | U.S.A.  
 Phone: 262.251.3800 | 800.558.8744 U.S.A./Canada | Fax: 262.251.7067 | [alto-shaam.com](http://alto-shaam.com)